

THE VALVE SPECIALISTS OF SCANDINAVIA

MESON VALVES



 **SANDER**
MESON
group

MESON

TABLE OF CONTENTS

MESON VALVES

ABOUT SANDER MESON GROUP

DIN

STOP VALVES	1:1-1:30
DIAPHRAGM VALVES	2:1-2:4
STORM FLAP VALVES & CHECK VALVES	3:1-3:34
GATE VALVES & KNIFE GATE VALVES	4:1-4:18
FIRE HOSE VALVES	5:1-5:3
BUTTERFLY VALVES	6:1-6:20
MUD BOXES & STRAINERS	7:1-7:16
BALL VALVES & PLUG VALVES	8:1-8:28
SAFETY VALVES & CONTROL VALVES	9:1-9:10
QUICK CLOSING & SELF CLOSING VALVES	10:1-10:13
STEAM TRAPS & PRESSURE REDUCING VALVES	11:1-11:3
GLOBE VALVES & FLAP VALVES, TYPE WT-MESON	12:1-12:3
VARIOUS OTHER EQUIPMENT	13:1-13:10

ANSI

STOP VALVES	14:1-14:4
CHECK VALVES	15:1-15:2
GATE VALVES	16:1-16:2
STRAINERS	17:1-17:4
BALL VALVES	18:1-18:4

JIS

STOP VALVES	19:1-19:16
STORM FLAP VALVES & CHECK VALVES	20:1-20:2
GATE VALVES	21:1-21:5
BUTTERFLY VALVES	22:1

ACTUATORS

ELECTRIC ACTUATORS	23:1-23:2
HYDRAULIC ACTUATORS	23:3-23:4
PNEUMATIC ACTUATORS	23:5
LIMIT SWITCH	23:6
SOLENOID VALVES	23:7

FITTINGS, SPARE PARTS AND MODIFICATION

PIPE COUPLINGS & REPAIR COUPLINGS	24:1
PIPE FITTINGS	25:1

TECHNICAL INFORMATION

FLANGE DIMENSIONS – DIN	26:1
FLANGE DIMENSIONS – JIS	26:2
FLANGE DIMENSIONS – ANSI	26:3
HOW TO MEASURE A VALVE	26:4
VARIATIONS	26:5
INDEX	27:1

SANDER MESON FLOW TECHNOLOGY

OUR KNOWLEDGE TAKES YOU FURTHER

A QUALITY SOLUTION

Sander Meson Group, a global supplier of products, systems and services to manage fluids in all applications in the marine, navy and oil and gas industry. Since 1929 we have been developing standard and individual solutions for navy, marine and offshore, from valves to the complex flow automation of piping and tank systems.

We continuously develop our products to meet new demands and by controlling the complete supply chain from manufacturing, testing to delivery and commissioning, we are able to offer high quality and cost effective solutions with short lead time. In the same time, with our expertise, our own production facilities and long experience, we can offer tailor made solutions to meet your demands in all situations.

Through large stocks, our own production facilities and the DNV, Lloyds, GL and RMRS approval for testing and certifying our products, we ensure fast deliveries around the world "24/7".

MESON AB
Kullsgårdsvägen 27
SE-312 34 Laholm
Sweden
Phone. +46 430 295 00
sales@meson.se

www.meson.se
www.sandermeson.com



DIN

VALVES ACCORDING TO EUROPEAN NORM (EN)
AND HISTORICALLY COMMON GERMAN STANDARD
DEUTSCHES INSTITUT FÜR NORMUNG (DIN).

The valves in this section mainly follow the normative dimensions and pressure classes from the mentioned standardization organization. If not found here you may find the type of valve suitable for your need in other sections as well and we may also have the possibility to adopt a valve to fit your needs. Don't hesitate to contact us with any inquiry.



STOP VALVES

For shut off and regulating purposes.
Can be delivered with non-return disc or regulating disc.
Available with threaded, flanged or weld end connections.
Metal to metal sealing or soft sealing.
Available with different types of actuators.



OVERBOARD VALVE

STRAIGHT, FLANGED ENDS

454022
PN16

DESCRIPTION: Straight type, Gunmetal Rg5 body, metal seated stop valve with bolted bonnet. Specially designed as overboard valve. Raised face flanged.

APPLICATION: Start/stop and throttling of: Sea water etc. Suitable as sea direct.

STANDARD & DESIGN:

- Design Code: -
- Inspection Std.: -
- End Std.: -
- Face to Face Std.: -
- Flanges drilled: PN16 (DN15-DN150)
- Pressure rating: PN16 (DN15-DN150)

VARIATIONS: Can be supplied with non return disc. Other dimensions and materials on request.

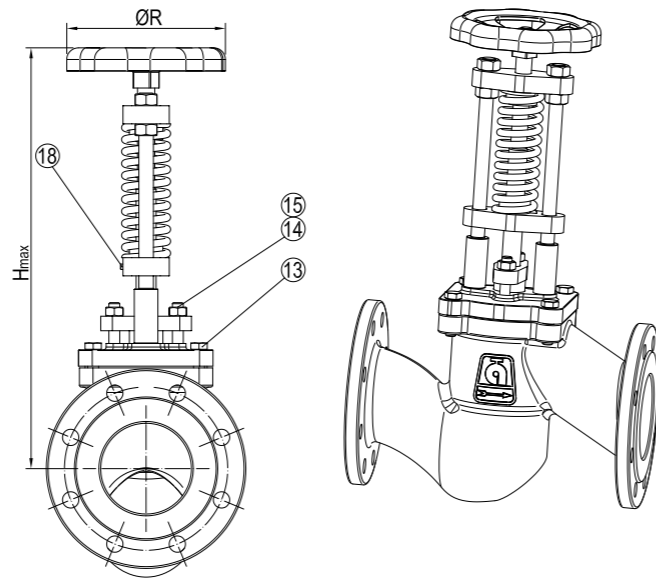

No	Part	Material	Code
1	Body	Bronze	CC 491K
2	Bonnet	Bronze	CC 491K
3	Gland	Bronze	CC 491K
4	Disc	Bronze	CC 491K
5	Stem	Brass	CW 602N
6	Disc Nut	Bronze	CC 491K
7	Bonnet Gasket	Dixo 4000	-
8	Stem Packing	PTFE	-
9	Pillar	Steel	EN 1.0718
10	Bridge Upper	Bronze	CC 491K
11	Bridge Lower	Bronze	CC 491K
12	Spring	Steel	-
13	Bolt	Stainless Steel	EN 1.4404
14	Nut	Stainless Steel	EN 1.4404
15	Stud	Stainless Steel	EN 1.4404
16	Nut	Stainless Steel	EN 1.4404
17	Washer	Stainless Steel	EN 1.4404
18	Set Screw	Stainless Steel	EN 1.4404
19	Hand Wheel	Cast Iron	EN JS1030

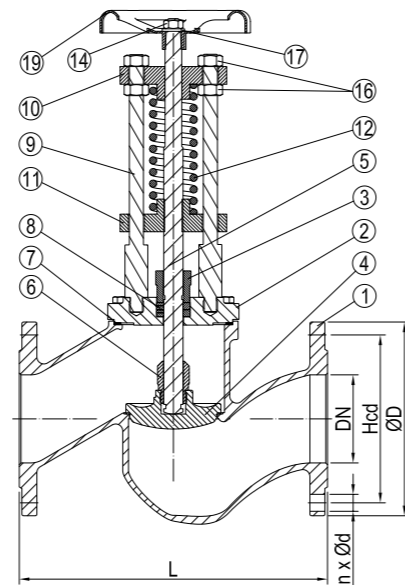

DN	n x ød	Hcd	øD	L	H _{max}	øR	Kg
15	4x14	65	95	130	245	80	3.5
20	4x14	75	105	150	245	80	4.0
25	4x14	85	115	160	250	80	5.0
32	4x18	100	140	180	282	100	6.1
40	4x18	110	150	200	315	120	8.4
50	4x18	125	165	230	335	140	12.0
65	4x18	145	185	290	410	140	16.0
80	8x18	160	200	310	465	180	22.5
100	8x18	180	220	350	550	180	29.0
125	8x18	210	250	400	550	200	46.0
150	8x22	240	285	480	624	250	70.6



OVERBOARD VALVE

ANGLE TYPE, FLANGED ENDS

454122
PN16

DESCRIPTION: Angled type, Gunmetal Rg5 body, metal seated stop valve with bolted bonnet. Specially designed as overboard valve. Raised face flanged.

APPLICATION: Start/stop and throttling of: Sea water etc. Suitable as sea direct.

STANDARD & DESIGN:

- Design Code: -
- Inspection Std.: -
- End Std.: -
- Face to Face Std.: -
- Flanges drilled: PN16 (DN15-DN150)
- Pressure rating: PN16 (DN15-DN150)

VARIATIONS: Can be supplied with non return disc. Other dimensions and materials on request.

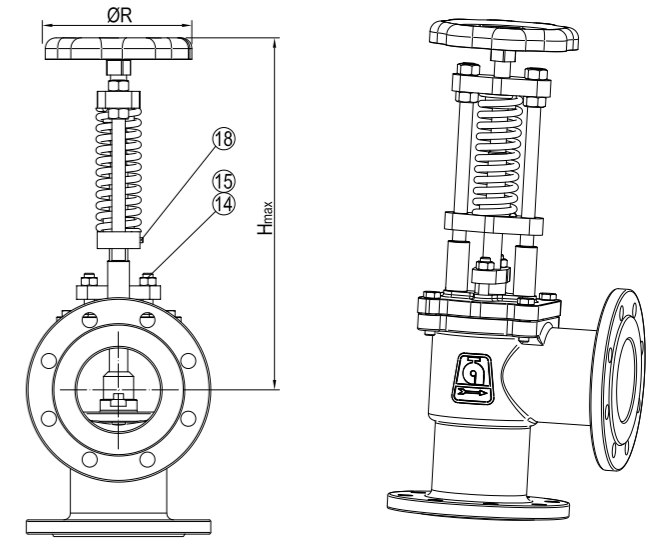

No	Part	Material	Code
1	Body	Bronze	CC 491K
2	Bonnet	Bronze	CC 491K
3	Gland	Bronze	CC 491K
4	Disc	Bronze	CC 491K
5	Stem	Brass	CW 602N
6	Disc Nut	Bronze	CC 491K
7	Bonnet Gasket	Dixo 4000	-
8	Stem Packing	PTFE	-
9	Pillar	Steel	EN 1.0718
10	Bridge Upper	Bronze	CC 491K
11	Bridge Lower	Bronze	CC 491K
12	Spring	Steel	-
13	Bolt	Stainless Steel	EN 1.4404
14	Nut	Stainless Steel	EN 1.4404
15	Stud	Stainless Steel	EN 1.4404
16	Nut	Stainless Steel	EN 1.4404
17	Washer	Stainless Steel	EN 1.4404
18	Set Screw	Stainless Steel	EN 1.4404
19	Hand Wheel	Cast Iron	EN JS1030

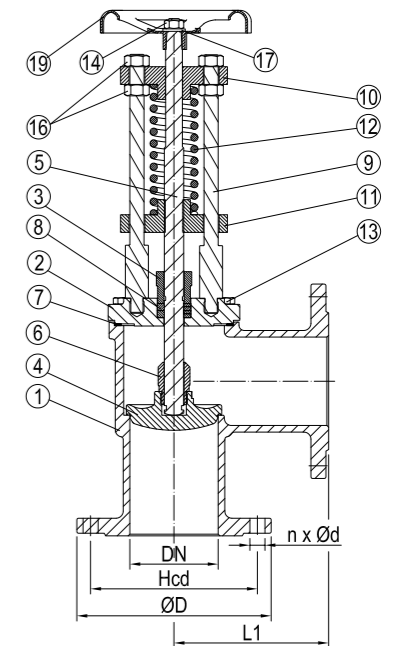

DN	n x ød	Hcd	øD	L1	H _{max}	øR	Kg
15	4x14	65	95	90	245	80	4.0
20	4x14	75	105	95	245	80	4.5
25	4x14	85	115	100	250	80	6.0
32	4x18	100	140	105	255	100	7.5
40	4x18	110	150	115	290	120	9.0
50	4x18	125	165	125	335	140	11.0
65	4x18	145	185	145	410	140	16.0
80	8x18	160	200	155	425	180	21.5
100	8x18	180	220	175	460	180	29.0
125	8x18	210	250	200	540	200	49.0
150	8x22	240	285	225	585	250	68.0



GLOBE VALVE

STRAIGHT, THREADED ENDS

335032
PN16

DESCRIPTION: Straight type, Rg10 body, PTFE soft seated screw down stop valve with rising stem, screwed and secured bonnet. BSPP female thread.

APPLICATION:

Start/stop and throttling of: Sea water, water, oils and steam etc.

STANDARD & DESIGN:

Design Code: -
 Inspection Std.: -
 End Std.: BSP-female acc. to DIN EN 10226-1 (DIN 2999)
 Face to Face Std.: -
 Pressure rating: PN16 (DN10-DN50)
 Temperature range: -10°C to +200°C

VARIATIONS:

Can be supplied with regulating disc.

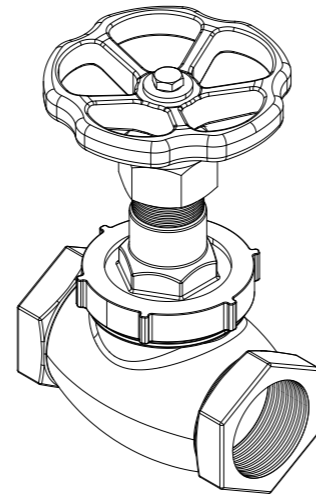

Pressure & Temperature ranges:

Bore	Working Pressure(Bar)	
	120°C	200°C
DN10-DN100 (3/8"-4")	16	12

No	Part	Material	Code
1	Body	Bronze	Rg10
2	Bonnet	Bronze	Rg10
3	Disc	Bronze	Rg10
4	Stem	Brass	CuZn35Ni
5	Bonnet Nut	Bronze	Rg10
6	Gland Nut	Brass	CuZn39Pb3
7	Gland Packing	Graphite	-
8	Gland	Brass	CuZn39Pb3
9	Bonnet Gasket	Teflon	PTFE
10	Washer	Steel	Grade 8
11	Bolt	Steel	Grade 8.8
12	Circlip	Stainless Steel	AISI316
13	Handwheel	Cast Iron	EN-GJL250
14	Disc Sealing	Teflon	PTFE

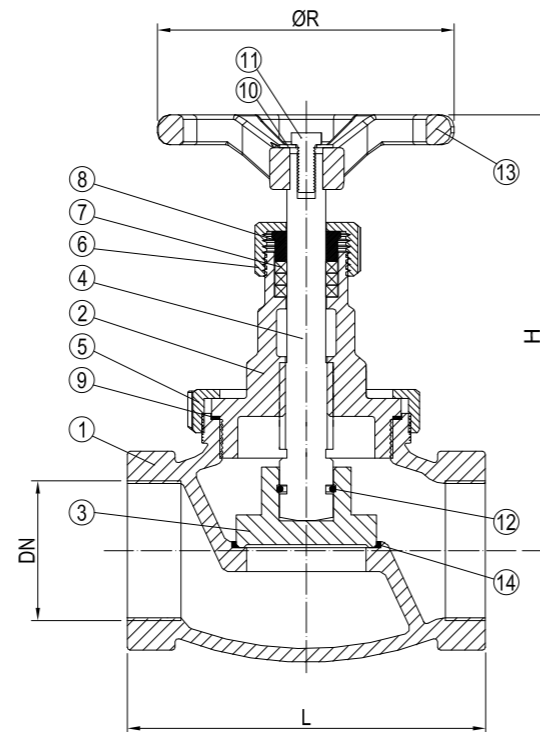

DN	Inch	L	H	øR	Kg
10	3/8	56	102	63	0.6
15	1/2	67	102	63	0.6
20	3/4	80	117	80	1.0
25	1	95	124	80	1.4
32	1 1/4	112	130	90	2.0
40	1 1/2	132	147	100	3.1
50	2	160	172	125	4.4



GLOBE VALVE

STRAIGHT, THREADED ENDS

456022
PN16

DESCRIPTION: Straight type, Rg5 body, metal seated screw down stop valve with rising stem, screwed and secured bonnet. BSPP female thread.

APPLICATION: Stop and throttling of: Sea water, water, oils and steam etc.

STANDARD & DESIGN:

Design Code: -
 Inspection Std.: -
 End Std.: BSP-female acc. to DIN EN 10226-1 (DIN 2999)
 Face to Face Std.: -
 Pressure rating: PN16 (DN10-DN100)
 Temperature range: -10°C to +200°C

VARIATIONS: Can be supplied with regulating disc.

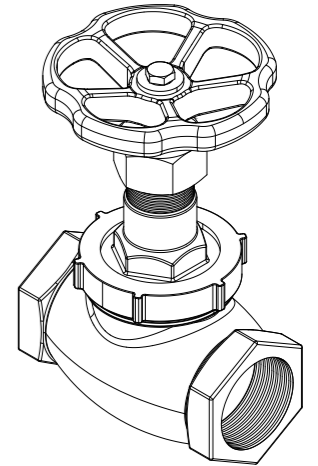

Pressure & Temperature ranges:

Bore	Working Pressure(Bar)	
	120°C	200°C
DN10-DN100 (3/8"-4")	16	12

No	Part	Material	Code
1	Body	Bronze	CuSn5ZnPb5-C
2	Bonnet	Bronze	CuSn5ZnPb5-C
3	Disc	Bronze	CuSn5ZnPb5-C
4	Stem	Brass	CuZn35Ni
5	Bonnet Nut	Bronze	CuSn5ZnPb5-C
6	Gland Nut	Brass	CuZn39Pb3
7	Gland Packing	Graphite	-
8	Gland	Brass	CuZn39Pb3
9	Bonnet Gasket	Teflon	PTFE
10	Washer	Steel	Grade 8
11	Bolt	Steel	Grade 8.8
12	Circlip	Stainless Steel	AISI316
13	Handwheel	Cast Iron	EN-GJL250

DN	Inch	L	H	øR	Kg
10	3/8	60	102	63	0.6
15	1/2	65	102	63	0.6
20	3/4	75	117	80	1.0
25	1	90	124	80	1.4
32	1 1/4	105	130	90	2.0
40	1 1/2	120	147	100	3.1
50	2	145	172	125	4.4
65	2 1/2	170	180	160	6.0
80	3	200	230	200	8.0
100	4	220	250	200	12.0

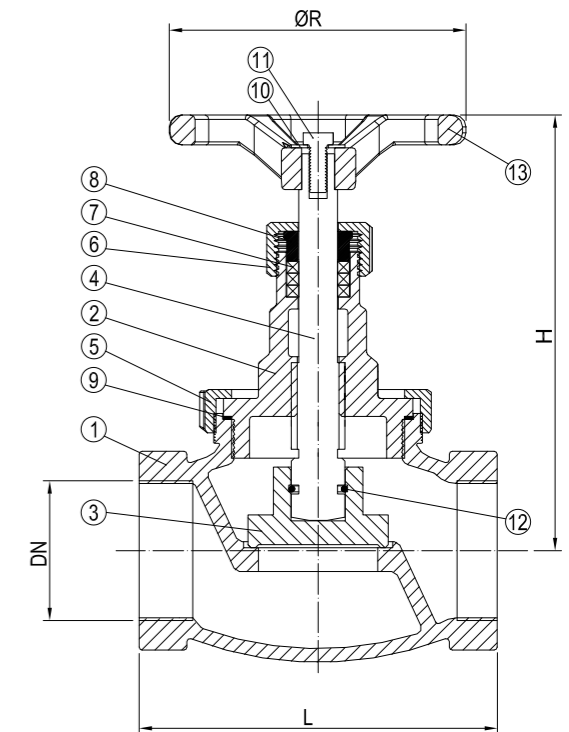



GLOBE VALVE

STRAIGHT, THREADED ENDS

456065
PN63

DESCRIPTION: Straight type, forged steel body stop valve, Stellite seat with rising stem and bolted bonnet. BSPT female thread.

APPLICATION:

Start/stop and throttling of: Air, water, steam, oils and aggressive/abrasive media etc.

STANDARD & DESIGN:

Design Code: BS 5352
 Inspection Std.: EN 12266-1
 End Std.: BSPT
 Face to Face Std.: -
 Pressure rating: PN63 (DN10-DN50)

VARIATIONS: Other dimensions and materials on request.

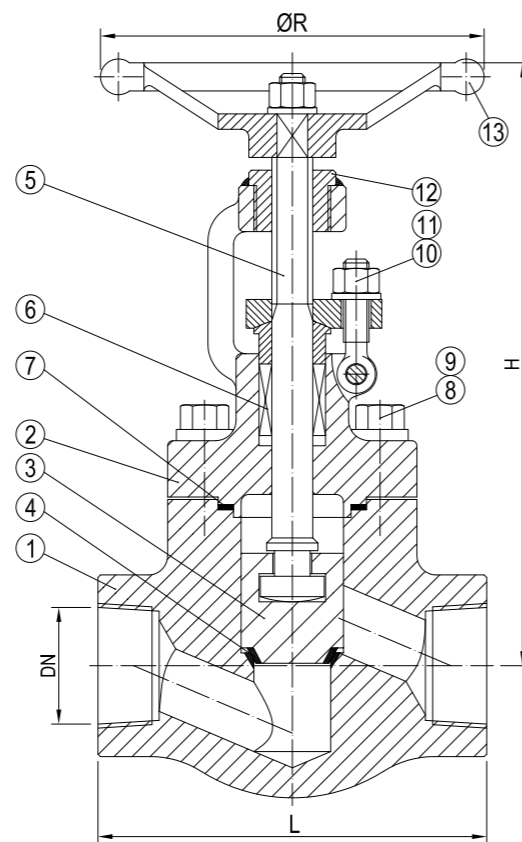
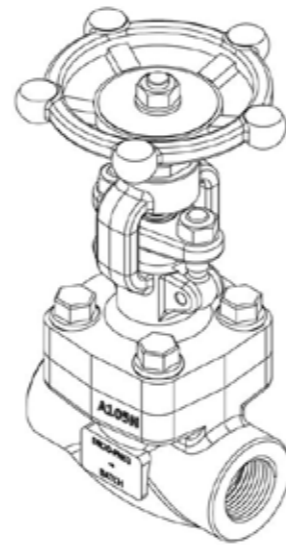

No	Part	Material	Code
1	Body	Forged Steel	ASTM A105
2	Bonnet	Forged Steel	ASTM A105
3	Disc	Stainless Steel	ASTM A276-420
4	Seat	Deposited Stellite	-
5	Stem	Stainless Steel	ASTM A276-410
6	Packing	Graphite	-
7	Bonnet Gasket	Graphite/304	-
8	Stud Bolt	Steel	ASTM A193 Gr.B7
9	Nut	Steel	ASTM A193 Gr.B7
10	Eye Bolt	Steel	ASTM A194 Gr.2H
11	Gland Nut	Steel	ASTM A193 Gr.B8
12	Stem Nut	Steel	1045
13	Handwheel	Malleable Iron	ASTM A197

DN	Inch	L	H	øR	Kg
10	3/8	79	155	100	2.0
15	1/2	79	155	100	2.3
20	3/4	92	155	100	2.4
25	1	111	176	125	4.3
32	1 1/4	120	200	160	5.7
40	1 1/2	152	220	160	7.8
50	2	172	255	180	12.5



GLOBE VALVE

STRAIGHT, BUTT WELDED ENDS

456066-114
PN160

DESCRIPTION: Straight type, forged steel body stop valve, Stellite with rising stem and bolted bonnet. Butt weld ends.

APPLICATION: Start/stop and throttling of: Air, water, steam, oils and aggressive media etc.

STANDARD & DESIGN:

Design Code: BS 5352
 Inspection Std.: EN 12266-1
 End Std.: Butt Welded ends acc. to BS EN12627-1999
 Face to Face Std.: -
 Pressure rating: PN160 (DN15-DN50)

VARIATIONS: Other dimensions and materials on request.

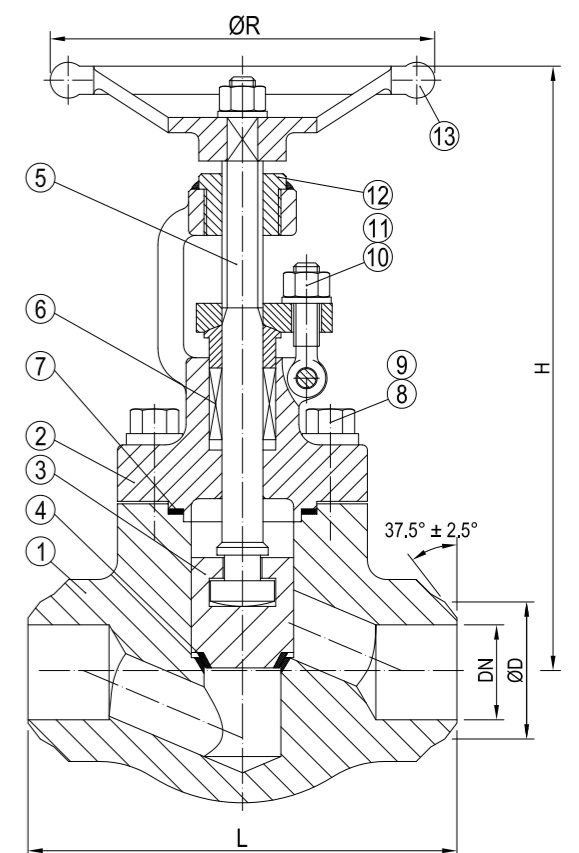
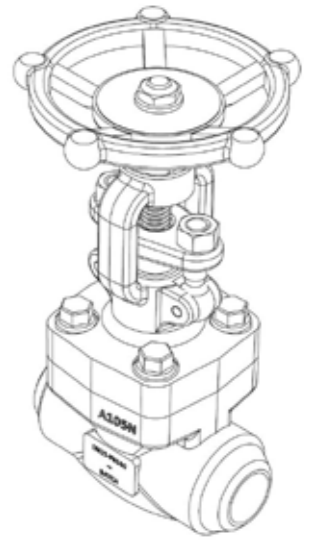

No	Part	Material	Code
1	Body	Forged Steel	ASTM A105
2	Bonnet	Forged Steel	ASTM A105
3	Disc	Stainless Steel	ASTM A276-420
4	Seat	Deposited Stellite	-
5	Stem	Stainless Steel	ASTM A276-410
6	Packing	Graphite	-
7	Bonnet Gasket	Graphite/304	-
8	Stud Bolt	Steel	ASTM A193 Gr.B7
9	Nut	Steel	ASTM A193 Gr.B7
10	Eye Bolt	Steel	ASTM A194 Gr.2H
11	Gland Nut	Steel	ASTM A193 Gr.B8
12	Stem Nut	Steel	1045
13	Handwheel	Malleable Iron	ASTM A197

DN	øD	L	H	øR	Kg
15	22	111	125	125	2.3
20	28	111	125	125	2.4
25	35	120	160	160	4.3
32	44	152	180	180	5.7
40	50	172	200	200	7.8
50	62	200	220	220	12.5



GLOBE VALVE

STRAIGHT, THREADED ENDS

456092
200WOG

DESCRIPTION: Straight type, AISI 316 body metal seated screw down stop valve with rising stem. Screwed bonnet. BSPP female thread.

APPLICATION: Start/stop and throttling of: Air, water, steam, oils etc.

STANDARD & DESIGN:

- Design Code: -
- Inspection Std.: -
- End Std.: THREADED ENDS BSPP : BS 21
- Face to Face Std.: -
- Pressure rating: 200WOG(DN8-DN50)

VARIATIONS: Available in high temperature execution. Other dimensions and materials on request.

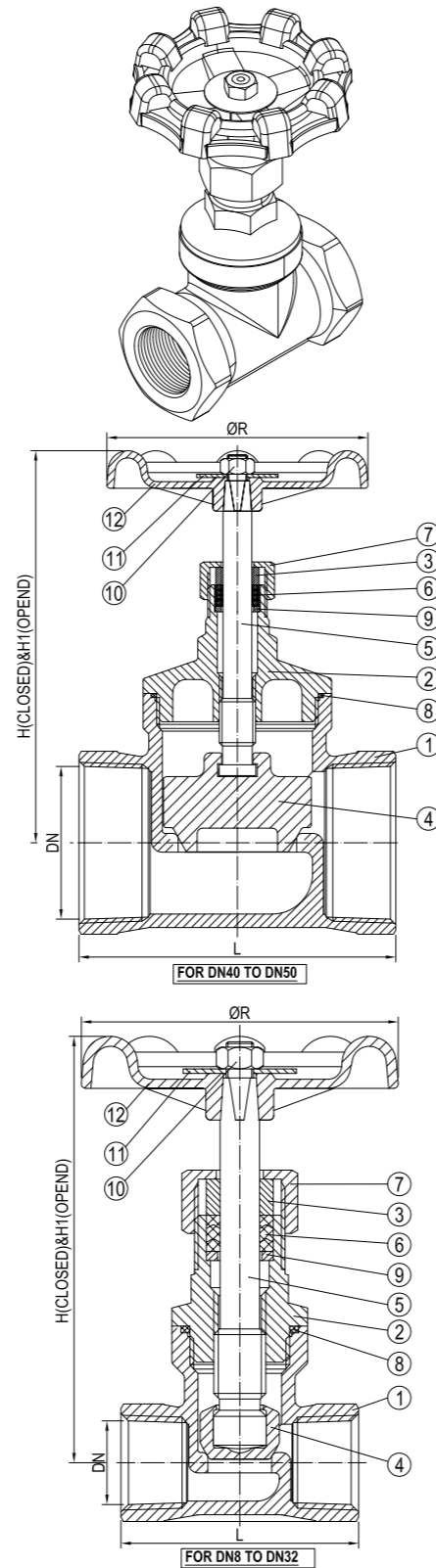
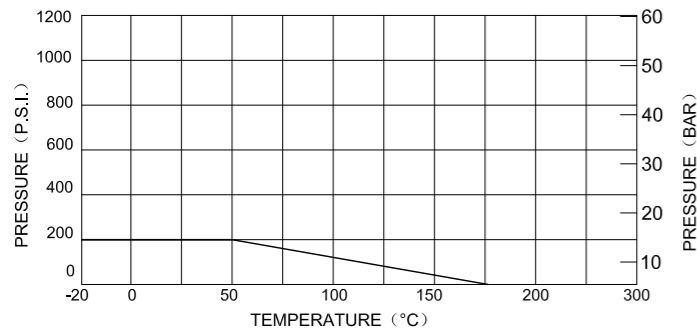

No	Part	Material	Code
1	Body	Stainless Steel	CF8M
2	Cap	Stainless Steel	CF8M
3	Gland	Stainless Steel	SUS 304
4	Disc	Stainless Steel	CF8M
5	Stem	Stainless Steel	SUS 316
6	Packing	PTFE	-
7	Cap Nut	Stainless Steel	CF8M
8	Gasket	PTFE	-
9	Whorl Gasket	Stainless Steel	SUS 304
10	Nut	Stainless Steel	SUS 304
11	Name plate	Aluminium	-
12	Handwheel	Aluminium	-

DN	Inch	L	H	H1	øR	Kg
8	1/4	52	91	103	70	0.3
10	3/8	52	91	103	70	0.3
15	1/2	52	91	103	70	0.3
20	3/4	66	100	111	80	0.5
25	1	76	104	121	80	0.7
32	1 1/4	86	135	156	90	1.0
40	1 1/2	94	133	147	90	1.3
50	2	118	154	175	100	2.2



GLOBE VALVE

ANGLE TYPE, THREADED ENDS

456122
PN16

DESCRIPTION: Angled type, Rg5 body, metal seated screw down stop valve with rising stem, screwed and secured bonnet. BSPP female thread.

APPLICATION: Sea water, water and low pressure steam. Stop and flow throttling of: Sea water, water, steam and oils etc.

STANDARD & DESIGN:

- Design Code: -
- Inspection Std.: -
- End Std.: BSP-female acc. to DIN EN 10226-1 (DIN 2999)
- Face to Face Std.: -
- Pressure rating: PN16 (DN10-DN80)
- Temperature range: -10°C to +200°C

VARIATIONS: Can be supplied with regulating disc. Other dimensions and materials on request.

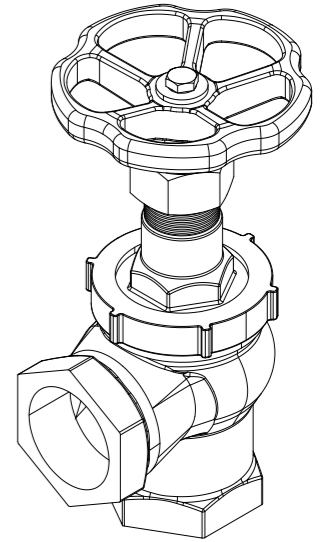

Pressure & Temperature ranges:

Bore	Working Pressure(Bar)	
	120°C	200°C
DN10-DN80 (3/8"-3")	16 Bar	12 Bar

No	Part	Material	Code
1	Body	Bronze	CuSn5Zn5Pb5-C
2	Bonnet	Bronze	CuSn5Zn5Pb5-C
3	Gland	Brass	CuZn39Pb3
4	Disc	Bronze	CuSn5Zn5Pb5-C
5	Stem	Brass	CuZn35Ni
6	Bonnet Nut	Bronze	CuSn5Zn5Pb5-C
7	Gland Nut	Brass	CuZn39Pb3
8	Gland Packing	Graphite	-
9	Bonnet Gasket	Teflon	PTFE
10	Washer	Steel	Gr. 8
11	Bolt	Steel	Gr. 8.8
12	Circlip	Stainless Steel	AISI316
13	Hand Wheel	Cast Iron	EN-GJL250

DN	Inch	L1	L2	H	øR	Kg
10	3/8	35	30	93	63	0.6
15	1/2	40	35	94	63	0.6
20	3/4	45	40	106	80	0.9
25	1	50	45	115	80	1.2
32	1 1/4	55	50	125	90	1.9
40	1 1/2	65	55	135	100	2.5
50	2	75	65	150	125	4.0
65	2 1/2	90	75	230	160	5.5
80	3	110	90	250	200	7.5

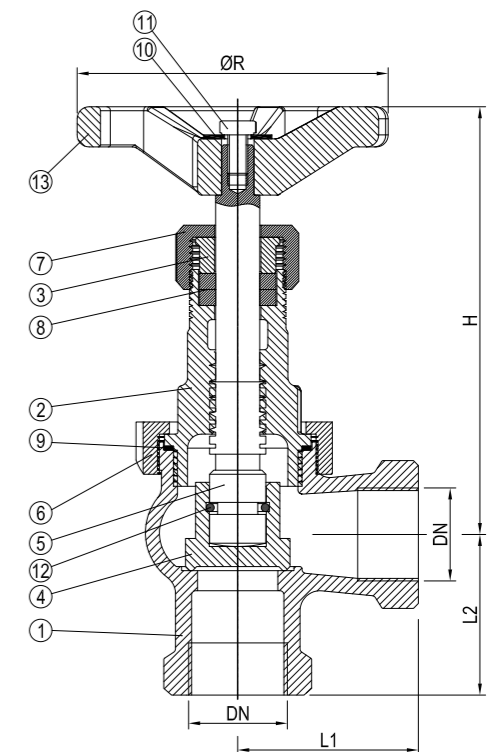



GLOBE VALVE

STRAIGHT TYPE, SCREWED BONNET

456322
PN16

DESCRIPTION: Short length, straight type, Rg5 body, metal seated screw down stop valve with rising stem, screwed and secured bonnet. Flat face flanged.

APPLICATION: Sea water, water and low pressure steam.
Start/stop and throttling of: Sea water, water, steam and oils etc.

STANDARD & DESIGN:

Design Code: -
Inspection Std.: -
End Std.: EN 1092-3/A (DIN 2501)
Face to Face Std.: -
Flanges drilled: PN16 (DN15-DN100)
Pressure rating: PN16 (DN15-DN100)
Temperature range: -10°C to +200°C

VARIATIONS: Can be supplied with regulating disc.
Other dimensions and materials on request.

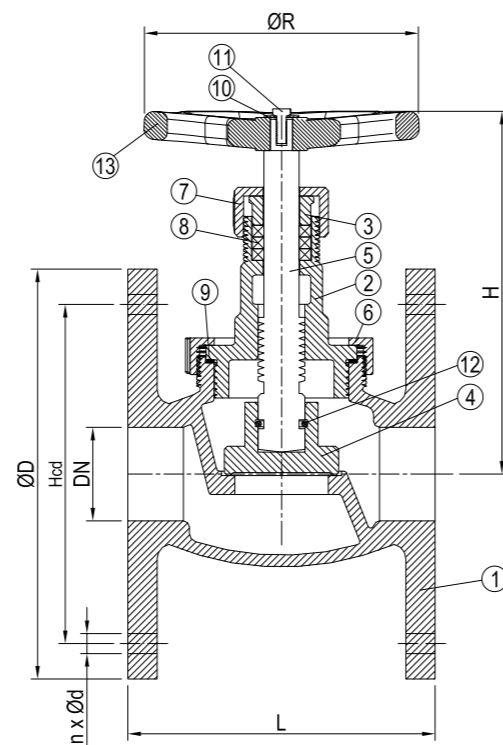
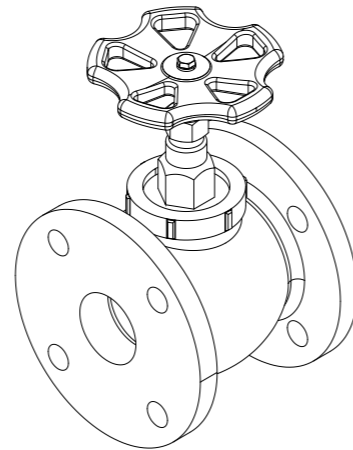

Pressure & Temperature ranges:

Bore	Working Pressure(Bar)	
	120°C	200°C
DN15-DN100	16 Bar	12 Bar

No	Part	Material	Code
1	Body	Bronze	CuSn5Zn5Pb5-C
2	Bonnet	Bronze	CuSn5Zn5Pb5-C
3	Gland	Brass	CuZn39Pb3
4	Disc	Bronze	CuSn5Zn5Pb5-C
5	Stem	Brass	CuZn35Ni
6	Bonnet Nut	Bronze	CuSn5Zn5Pb5-C
7	Gland Nut	Brass	CuZn39Pb3
8	Gland Packing	Graphite	-
9	Bonnet Gasket	PTFE	-
10	Washer	Steel	Gr. 8.8
11	Bolt	Steel	Gr. 8.8
12	Circlip	Stainless Steel	AISI316
13	Hand Wheel	Cast Iron	EN-GJL250

DN	n x ød	Hcd	øD	L	H	øR	Kg
15	4x14	65	95	70	102	63	1.5
20	4x14	75	105	80	117	80	2.3
25	4x14	85	115	90	124	80	3.0
32	4x18	100	140	105	130	90	5.0
40	4x18	110	150	120	147	100	6.5
50	4x18	125	165	140	172	125	8.0
65	4x18	145	185	180	230	160	13.0
80	8x18	160	200	200	250	200	17.0
100	8x18	180	220	230	250	200	21.0



GLOBE VALVE

STRAIGHT, FLANGED ENDS

457432
PN16

DESCRIPTION: Straight type, Rg10 body, metal seated screw down stop valve with rising stem, bolted bonnet. Flat face flanged connection.

APPLICATION: Start/stop and flow control of: Sea water, water and steam etc. Suitable as sea direct.

STANDARD & DESIGN:

Design Code: -
Inspection Std.: -
End Std.: -
Face to Face Std.: -
Flanges drilled: PN16(DN15-DN100)
Pressure rating: PN16(DN15-DN100)

VARIATIONS: Can be supplied with regulating disc and non return disc.
Other dimensions and materials on request.

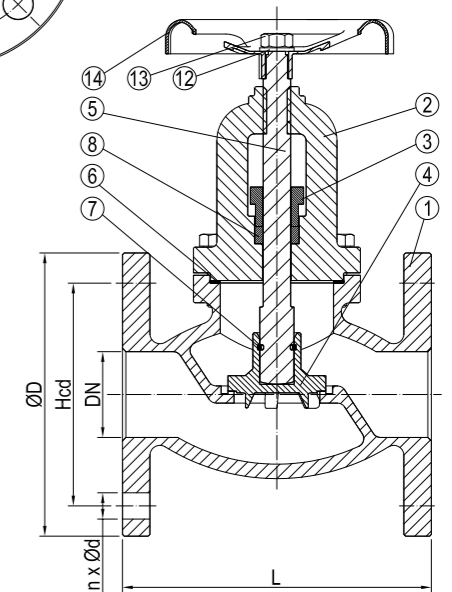
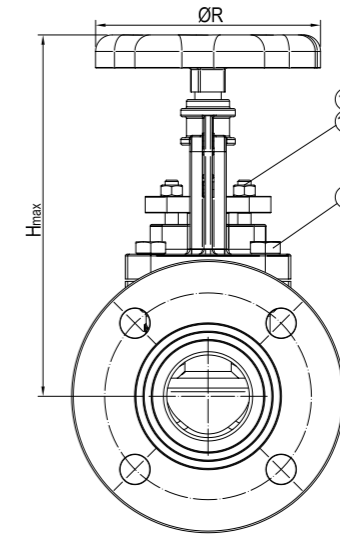
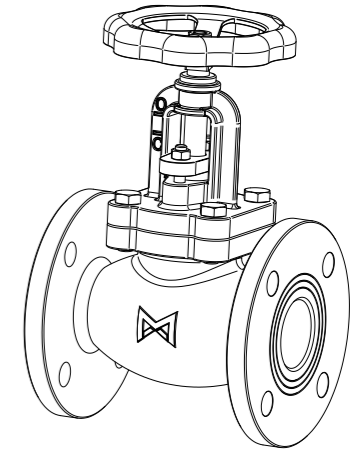

No	Part	Material	Code
1	Body	Bronze	CC 482K
2	Bonnet	Bronze	CC 482K
3	Gland	Bronze	CC 482K
4	Disc	Bronze	CC 481K
5	Stem	Al Bronze	CC 333G
6	Bonnet Gasket	Dixo 4000	-
7	Fixing Ring	Phospor Bronze	-
8	Stem Packing	Graphite	-
9	Bolt	Stainless Steel	EN 1.4404
10	Stud	Stainless Steel	EN 1.4404
11	Nut	Stainless Steel	EN 1.4404
12	Washer	Stainless Steel	EN 1.4404
13	Nut	Stainless Steel	EN 1.4404
14	Handwheel	Cast Iron	EN JS1030

DN	n x ød	Hcd	øD	L	H _{max}	øR	Kg
15	4x14	65	95	100	155	100	2.2
20	4x14	75	105	110	155	100	2.7
25	4x14	85	115	120	155	100	3.8
32	4x18	100	140	135	180	100	6.1
40	4x18	110	150	150	205	140	8.5
50	4x18	125	165	180	210	140	11.6
65	4x18	145	185	200	253	140	14.6
80	8x18	160	200	230	290	200	18.9
100	8x18	180	220	280	340	200	29.8



GLOBE VALVE

STRAIGHT, FLANGED ENDS

458822/21
PN16/PN10/
PN6/PN4

DESCRIPTION: Straight type, Rg5 body, metal seated screw down stop valve with rising stem, bolted bonnet. Raised face flanged.

APPLICATION: Start/stop and flow control of: Sea water, water, steam and oils etc. Suitable as sea direct.

STANDARD & DESIGN:

- Design Code: -
- Inspection Std.: -
- End Std.: -
- Face to Face Std.: -
- Flanges drilled: PN16(DN15-DN150)
PN10(DN200-DN350)
- Pressure rating: PN16(DN15-DN150)
PN10(DN200)
PN6(DN250-DN300)
PN4(DN350)

VARIATIONS: Can be supplied with regulating disc and non return disc.
Other dimensions and materials on request.

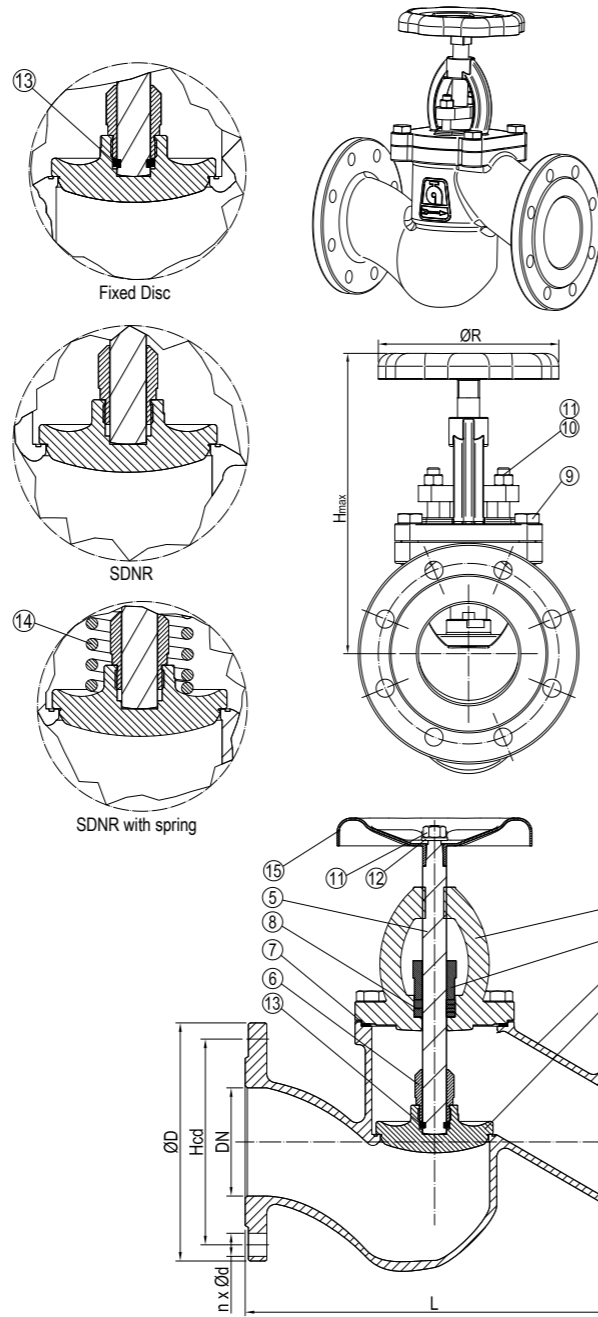

No	Part	Material	Code
1	Body	Bronze	CC 491K
2	Bonnet	Bronze	CC 491K
3	Gland	Bronze	CC 491K
4	Disc	Bronze	CC 491K
5	Stem	Brass	CW 602N
6	Disc Nut	Bronze	CC 491K
7	Bonnet Gasket	Dixo 4000	-
8	Stem Packing	Graphite	-
9	Bolt	Stainless Steel	EN 1.4404
10	Stud	Stainless Steel	EN 1.4404
11	Nut	Stainless Steel	EN 1.4404
12	Washer	Stainless Steel	EN 1.4404
13	Fixing Ring	Brass	CW 602N
14	Spring	Phospor Bronze	-
15	Handwheel	Cast Iron	EN JS1030

DN	n x ød	Hcd	øD	L	H _{max}	øR	Kg
15	4x14	65	95	130	140	100	2.5
20	4x14	75	105	150	150	100	3.0
25	4x14	85	115	160	160	100	3.8
32	4x18	100	140	180	165	100	5.0
40	4x18	110	150	200	195	140	7.0
50	4x18	125	165	230	205	140	9.6
65	4x18	145	185	290	255	160	13.6
80	8x18	160	200	310	290	200	19.0
100	8x18	180	220	350	335	200	26.9
125	8x18	210	250	400	405	250	44.0
150	8x22	240	285	480	445	320	66.0
200	8x22	295	340	600	530	320	130.0
250	12x22	350	395	730	640	400	220.0
300	12x22	400	445	850	720	400	305.0
350	16x22	460	505	980	900	500	430.0



GLOBE VALVE

ANGLE TYPE, FLANGED ENDS

458922/21
PN16/PN10/
PN6/PN4

DESCRIPTION: Angled type, Rg5 body, metal seated screw down stop valve with rising stem, bolted bonnet. Raised face flange.

APPLICATION: Start/stop and flow control of: Sea water, water, steam and oils etc. Suitable as sea direct.

STANDARD & DESIGN:

- Design Code: -
- Inspection Std.: -
- End Std.: -
- Face to Face Std.: -
- Flanges drilled: PN16(DN15-DN150)
PN10(DN200-DN350)
- Pressure rating: PN16(DN15-DN150)
PN10(DN200)
PN6(DN250-DN300)
PN4(DN350)

VARIATIONS: Can be supplied with regulating disc and non return disc.
Other dimensions and materials on request.

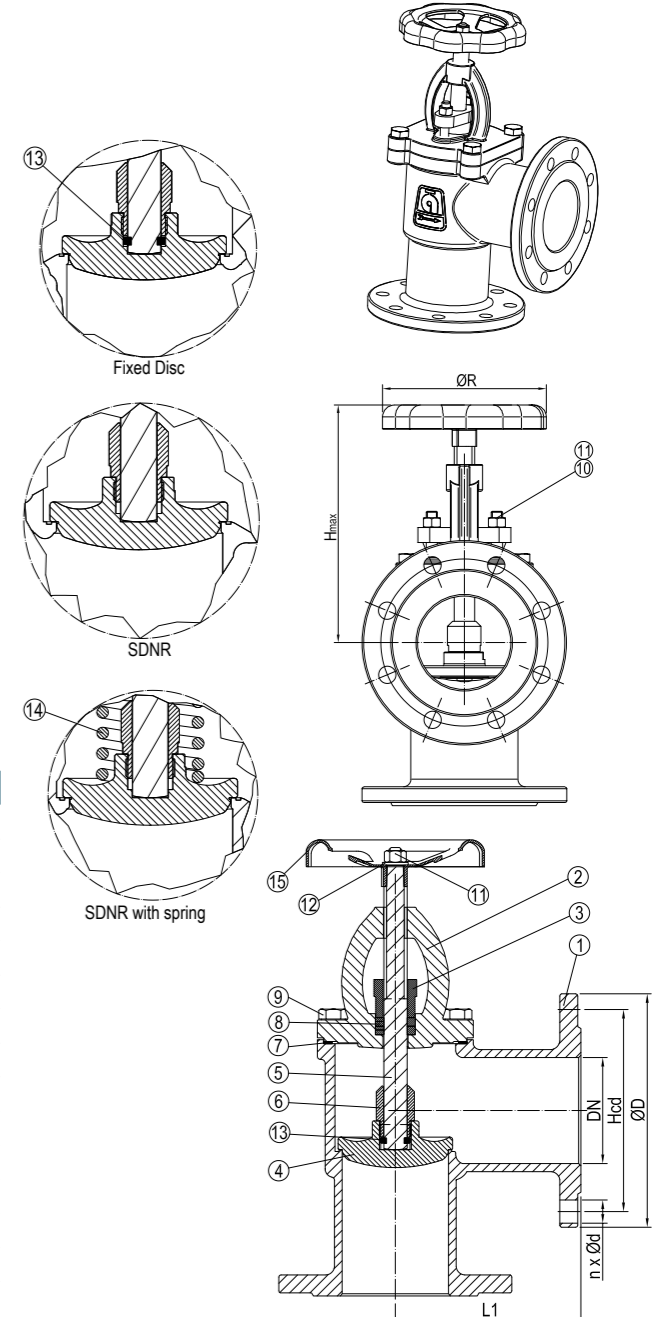

No	Part	Material	Code
1	Body	Bronze	CC 491K
2	Bonnet	Bronze	CC 491K
3	Gland	Bronze	CC 491K
4	Disc	Bronze	CC 491K
5	Stem	Brass	CW 602N
6	Disc Nut	Bronze	CC 491K
7	Bonnet Gasket	Dixo 4000	-
8	Stem Packing	Graphite	-
9	Bolt	Stainless Steel	EN 1.4404
10	Stud	Stainless Steel	EN 1.4404
11	Nut	Stainless Steel	EN 1.4404
12	Washer	Stainless Steel	EN 1.4404
13	Fixing Ring	Brass	CW 602N
14	Spring	Phospor Bronze	-
15	Handwheel	Cast Iron	EN JS1030

DN	n x ød	Hcd	øD	L1	H _{max}	øR	Kg
15	4x14	65	95	90	130	100	2.5
20	4x14	75	105	95	130	100	3.1
25	4x14	85	115	100	150	100	4.0
32	4x18	100	140	105	155	100	6.0
40	4x18	110	150	115	180	140	6.9
50	4x18	125	165	125	185	140	9.3
65	4x18	145	185	145	225	160	13.9
80	8x18	160	200	155	260	200	18.4
100	8x18	180	220	175	290	200	26.0
125	8x18	210	250	200	325	250	47.0
150	8x22	240	285	225	335	320	64.0
200	8x22	295	340	275	390	320	115.0
250	12x22	350	395	325	520	400	210.0
300	12x22	400	445	375	550	400	285.0
350	16x22	460	505	425	720	500	400.0



NEEDLE VALVE

STRAIGHT, THREADED ENDS

460515
PN100

DESCRIPTION: Straight type, Brass body & stem needle valve.
BSPP female thread.

APPLICATION: Instrumentation, start/stop and flow fine tuning of:
Air, water, steam and oils etc.

STANDARD & DESIGN:

Design Code: -
Inspection Std.: -
End Std.: BSP
Face to Face Std.: -
Pressure rating: PN100(DN8-DN15)

VARIATIONS: With locked gland nut.
Other dimensions and materials on request.

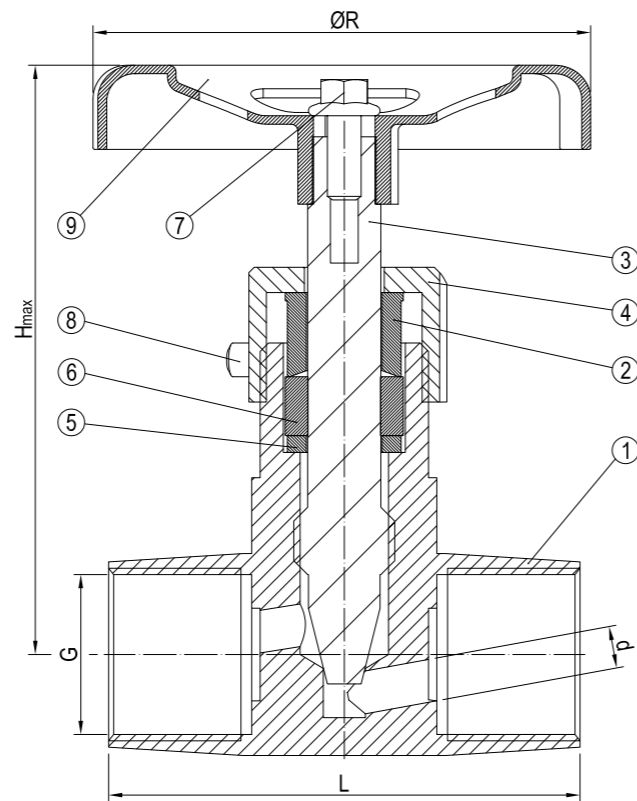
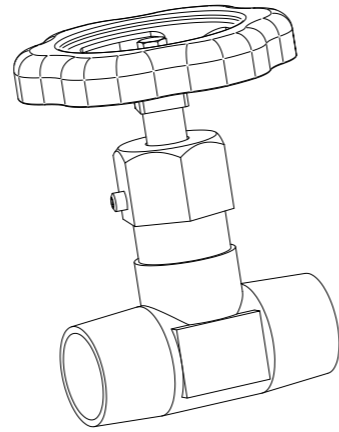

No	Part	Material	Code
1	Body	Brass	CW 614N
2	Gland	Brass	CW 614N
3	Stem	Brass	CW 614N
4	Gland Nut	Brass	CW 614N
5	Washer	Brass	CW 614N
6	Gland Packing	Graphite	-
7	Set Screw	Steel	-
8	Flange Screw	Steel	-
9	Handwheel	Steel	-

DN	G(Inch)	L	H _{max}	d	øR	Kg
8	1/4	48	70	4	60	0.3
10	3/8	54	75	5	60	0.3
15	1/2	56	75	5	60	0.4



NEEDLE VALVE

STRAIGHT, THREADED ENDS

460895
PN400

DESCRIPTION: Straight type AISI 316 body & stem needle valve.
BSPP female thread.

APPLICATION: Instrumentation, start/stop and flow fine tuning of:
Air, water, steam and oils etc.

STANDARD & DESIGN:

Design Code: -
Inspection Std.: -
End Std.: ISO-228
Face to Face Std.: -
Pressure rating: 6000PSI(PN400)(DN8-DN25)
Temperature range: -60°F to +450°F

VARIATIONS: Other dimensions and materials on request.

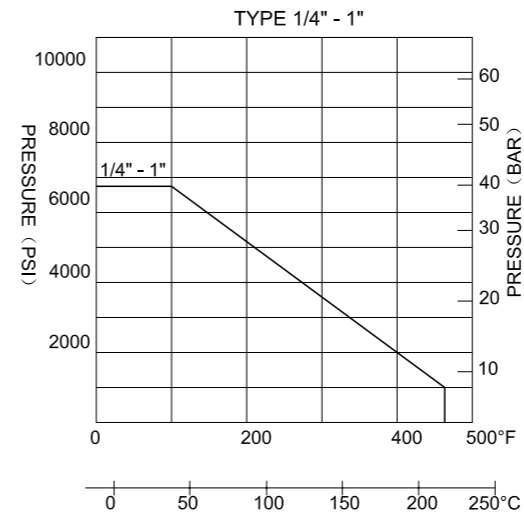
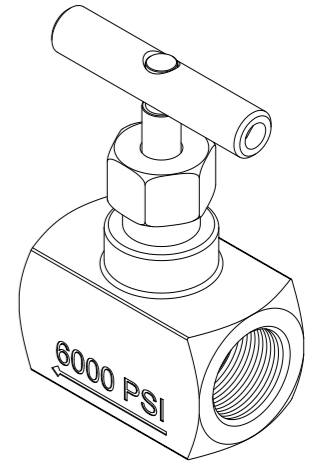

Class Needle Valve:
Cv value (igpm)

Size	1/4"	3/8"	1/2"	3/4"	1"
Cv value	0.5	0.8	1.3	2.8	5.3

No	Part	Material	Code
1	Body	Stainless Steel	316;CF8M
2	Stem	Stainless Steel	316
3	Stem Packing	Stainless Steel	304
4	Packing	Teflon	-
5	Gland Washer	Stainless Steel	304
6	Gland Nut	Stainless Steel	304;316
7	Handle	Stainless Steel	304
8	Bolts	Stainless Steel	304

DN	Inch	L	H	Kg
8	1/4	48	80	0.4
10	3/8	52	82	0.4
15	1/2	56	90	0.5
20	3/4	62	98	0.8
25	1	74	105	1.1

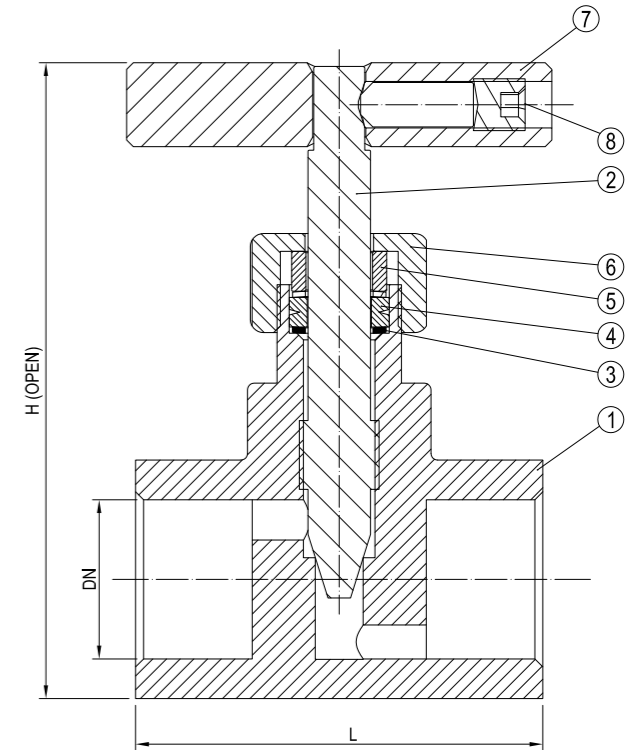



NEEDLE VALVE

ANGLE, THREADED ENDS

460995
PN400

DESCRIPTION: Angled type AISI 316 body & stem needle valve. BSPP female thread.

APPLICATION: Instrumentation, start/stop and flow fine tuning of: Air, water, steam and oils etc.

STANDARD & DESIGN:

Design Code: -
 Inspection Std.: -
 End Std.: ISO-228
 Face to Face Std.: -
 Pressure rating: 6000PSI(PN400)(DN8-DN25)
 Temperature range: -60°F to +450°F

VARIATIONS: Other dimensions and materials on request.

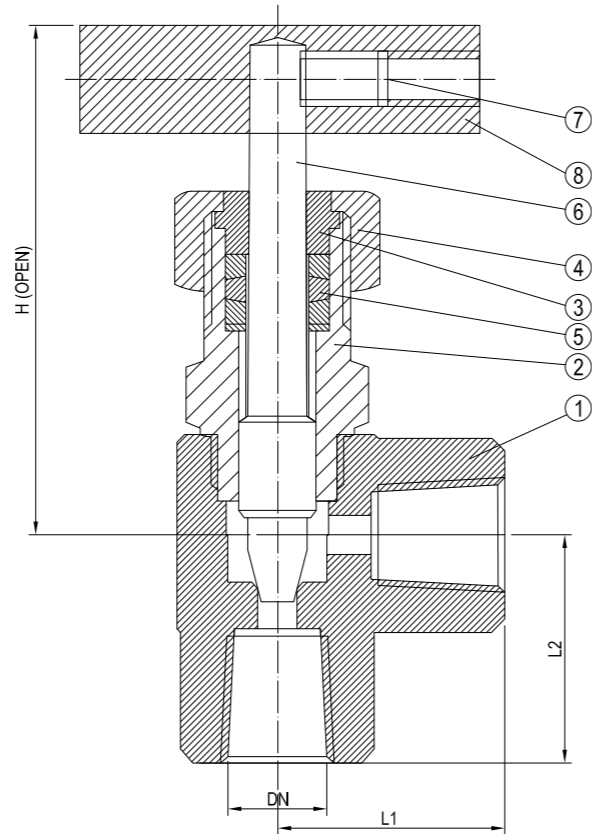
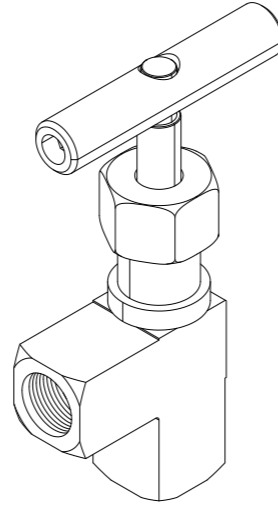

No	Part	Material	Code
1	Body	Stainless Steel	ASTM A-351 GR.CF8M
2	Bonnet	Stainless Steel	ASTM A-351 GR.CF8M
3	Gland	Stainless Steel	SS304
4	Gland Nut	Stainless Steel	SS304
5	Packing	Teflon	-
6	Stem	Stainless Steel	SS316
7	Set Screw	Stainless Steel	SS304
8	Handle	Stainless Steel	SS410

DN	Inch	L1	L2	H	Kg
8	1/4	29	29	75	0.4
10	3/8	29	29	75	0.4
15	1/2	34	34	87	0.6
20	3/4	38	38	90	0.7
25	1	45	45	103	1.2



SHUT-OFF VALVE

2 PIECE, THREADED ENDS

466694
PN40

DESCRIPTION: Y-type, AISI 316 equivalent body, PTFE soft seated screw down stop valve with rising stem. Screwed bonnett. BSPP female thread.

APPLICATION: Start/stop and throttling of: Air, water, steam and oils etc. Suitable for slurries and drainage containing particles.

STANDARD & DESIGN:

Design Code: -
 Inspection Std.: -
 End Std.: ISO 228
 Face to Face Std.: DIN 3202 Part 4, M8 series
 Pressure rating: PN40 (DN8-DN50)
 Temperature range: 0°C -180°C

VARIATIONS: Can be supplied with regulating disc and non return disc. Other dimensions and materials on request.

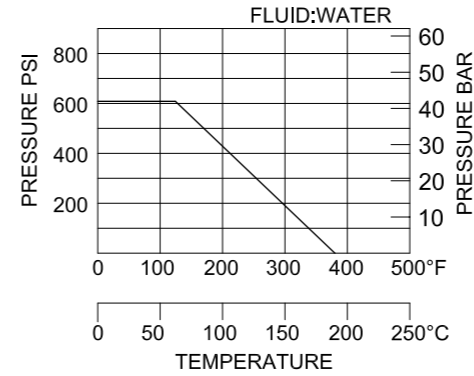
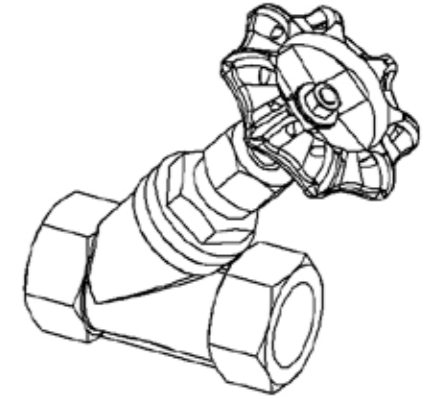

No	Part	Material	Code
1	Body	Stainless Steel	ASTM-A351-CF8M
2	Cap	Stainless Steel	ASTM-A351-CF8M
3	Seat	PTFE	-
4	Stem	Stainless Steel	AISI 316
5	Joint Gasket	PTFE	-
6	Packing	PTFE	-
7	Washer	Stainless Steel	AISI 304
8	Nut	Stainless Steel	AISI 316
9	Ring	Stainless Steel	AISI 304
10	Cap Nut	Stainless Steel	AISI 304
11	Handle Washer	Stainless Steel	AISI 304
12	Handle Nut	Stainless Steel	AISI 304
13	Handle	Steel	WCB

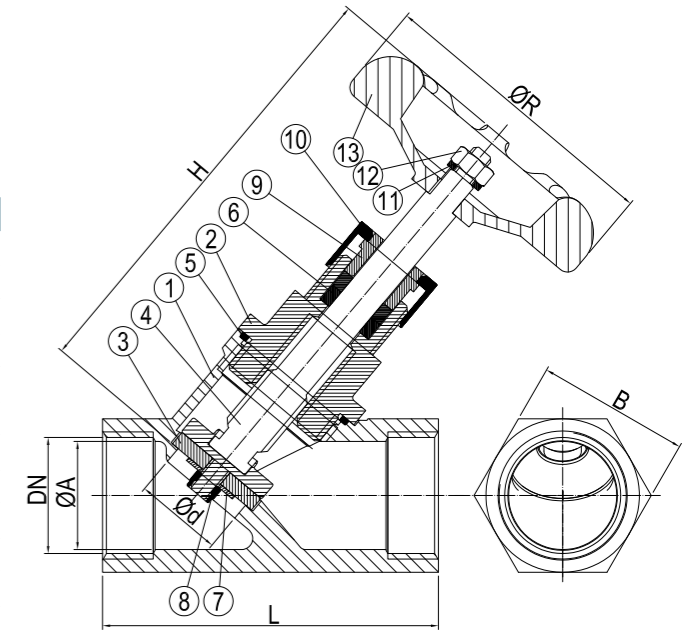

DN	Inch	L	H	øR	øA	ød	B	Kg
8	1/4	65.8	90.5	57	11	11.6	27	0.4
10	3/8	65.8	90.5	57	14	12.5	27	0.4
15	1/2	65.8	93.5	57	17.5	12.5	27	0.4
20	3/4	75.7	109.5	57	23	18	32.3	0.5
25	1	89.7	110.8	75	29	23.5	41	0.9
32	1 1/4	109.8	137.5	110.5	38	31.4	50	1.4
40	1 1/2	121	139	110.5	44	35.7	55.5	1.8
50	2	151.6	162	110.5	56	45.5	70	3.3



GLOBE VALVE

STRAIGHT TYPE, FLANGED ENDS

467002/01
PN16/PN10

DESCRIPTION: Straight type, ductile cast iron body, metal seated screw down stop valve with rising stem, bolted bonnet. Raised face flanged connection.

APPLICATION: Aboard ships for hot and cold water, oil and steam. Start/stop and throttling of: Sea water, water, steam and oils etc. Suitable as sea direct.

VARIATIONS: Can be supplied with regulating disc and non return disc. Stainless steel trim. With open/close indication

STANDARD & DESIGN:

Design Code: DIN 86251 Stop type (DIN 3356)
 Inspection Std.: -
 End Std.: EN 1092-2/B (DIN 2501)
 Face to Face Std.: EN 558 series 1 (DIN 3202 F1)
 Flanges drilled: PN16 (DN15-DN150)
 PN10 (DN200-DN600)
 Pressure rating: PN16 (DN15-DN150)
 PN10 (DN200-DN250)
 PN6 (DN300-DN350)
 PN4 (DN400-DN600)

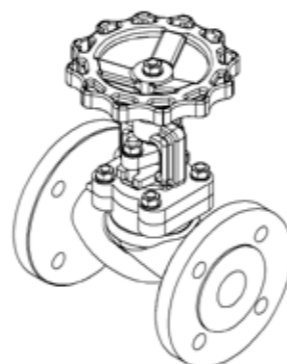

Pressure & Temperature ranges:

Bore	Working Pressure(Bar)	
	120°C	180°C
DN15-DN150	16	10
DN200-DN250	10	6
DN300-DN350	6	4
DN400-DN600	4	2

No	Part	Material	Code
1	Body	Nodular Cast Iron	EN-GJS400-18-LT
2	Bonnet	Nodular Cast Iron	EN-GJS400-18-LT
3	Seat	Bronze	CuSn5Zn5Pb5-C
4	Disc(<=65) (>=80)	Bronze Nodular Cast Iron	CuSn5Zn5Pb5-C EN-GJS400-18-LT
5	Stem	Brass	CuZn35Ni3Mn2AlPb
6	Gland Packing	Graphite	-
7	Bonnet Gasket	Graphite	-
8	Stud Bolt	Steel	-
9	Nut	Steel	-
10	Hand Wheel	Cast Iron	EN-GJL250

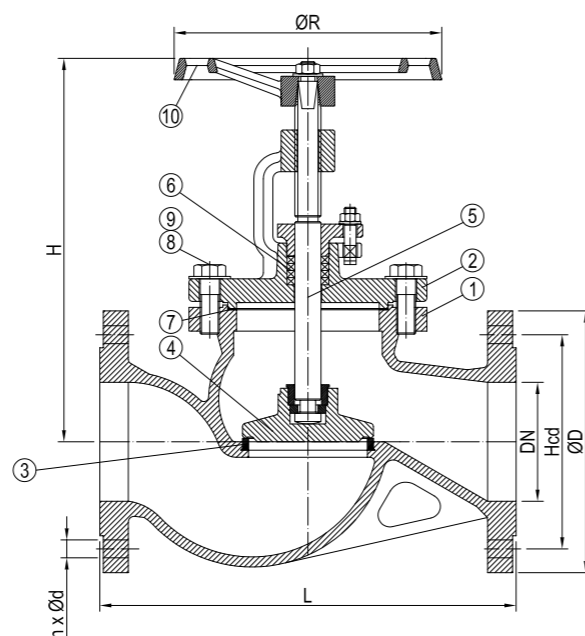

DN	n x ød	Hcd	øD	L	H	øR	Kg
15	4x14	65	95	130	165	120	4
20	4x14	75	105	150	165	120	4
25	4x14	85	115	160	175	140	5
32	4x18	100	140	180	180	140	7
40	4x18	110	150	200	220	160	11
50	4x18	125	165	230	230	160	13
65	4x18	145	185	290	245	180	18
80	8x18	160	200	310	295	200	25
100	8x18	180	220	350	330	225	35
125	8x18	210	250	400	365	250	55
150	8x22	240	285	480	420	300	75
200	8x22	295	340	600	510	400	135
250	12x22	350	395	730	600	520	215
300	12x22	400	445	850	670	520	305
350	16x22	460	505	980	755	640	405
400	16x26	515	565	1100	835	640	550
450	20x26	565	615	1200	920	640	690
500	20x26	620	670	1250	970	640	835
600	20x30	725	780	1450	1200	640	1050



GLOBE VALVE

STRAIGHT TYPE, FLANGED ENDS

467052/51
PN16/PN10

DESCRIPTION: Straight type, grey cast iron body, metal seated screw down stop valve with rising stem, bolted bonnet. Raised face flanged connection.

APPLICATION: Aboard ships for hot and cold water and oil. Start/stop and throttling of: Sea water, water and oils etc.

VARIATIONS: Can be supplied with regulating disc and non return disc. Stainless steel trim. With open/close indication

STANDARD & DESIGN:

Design Code: DIN 86251 Stop Type (DIN 3356)
 Inspection Std.: -
 End Std.: EN 1092-2/B (DIN 2501)
 Face to Face Std.: EN 558 series 1 (DIN 3202 F1)
 Flanges drilled: PN16 (DN15-DN150)
 PN10 (DN200-DN600)
 Pressure rating: PN16 (DN15-DN150)
 PN10 (DN200-DN250)
 PN6 (DN300-DN350)
 PN4 (DN400-DN600)

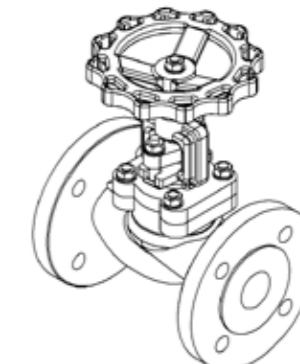

Pressure & Temperature ranges:

Bore	Working Pressure(Bar)	
	120°C	180°C
DN15-DN150	16	10
DN200-DN250	10	6
DN300-DN350	6	4
DN400-DN600	4	2

No	Part	Material	Code
1	Body	Cast Iron	EN-GJL250
2	Bonnet	Cast Iron	EN-GJL250
3	Seat	Bronze	CuSn5Zn5Pb5-C
4	Disc(<=65) (>=80)	Bronze Nodular Cast Iron	CuSn5Zn5Pb5-C EN-GJS400-18-LT
5	Stem	Brass	CuZn35Ni3Mn2AlPb
6	Gland Packing	Graphite	-
7	Bonnet Gasket	Graphite	-
8	Stud Bolt	Steel	-
9	Nut	Steel	-
10	Hand Wheel	Cast Iron	EN-GJL250

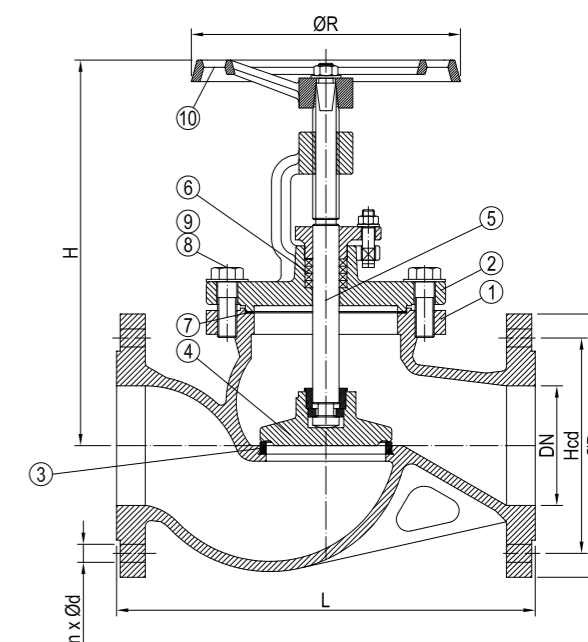

DN	n x ød	Hcd	øD	L	H	øR	Kg
15	4x14	65	95	130	165	120	4
20	4x14	75	105	150	165	120	4
25	4x14	85	115	160	175	140	5
32	4x18	100	140	180	180	140	7
40	4x18	110	150	200	220	160	11
50	4x18	125	165	230	230	160	13
65	4x18	145	185	290	245	180	18
80	8x18	160	200	310	295	200	25
100	8x18	180	220	350	330	225	35
125	8x18	210	250	400	365	250	55
150	8x22	240	285	480	420	300	75
200	8x22	295	340	600	510	400	135
250	12x22	350	395	730	600	520	215
300	12x22	400	445	850	670	520	305
350	16x22	460	505	980	755	640	405
400	16x26	515	565	1100	835	640	550
450	20x26	565	615	1200	920	640	690
500	20x26	620	670	1250	970	640	835
600	20x30	725	780	1450	1200	640	1050



GLOBE VALVE

STRAIGHT TYPE, FLANGED ENDS

467064
PN40

DESCRIPTION: Straight type, cast steel body, metal seated screw down stop valve with rising stem, bolted bonnet. Raised face flanged connection.

APPLICATION:
Steam, cold, hot water, oil and gases and aggressive media, for higher temperatures and pressures.
Start/stop and throttling of: Water, steam, oils etc.

STANDARD & DESIGN:
Design Code: DIN EN13709 Stop type (DIN 3356)
Inspection Std.: -
End Std.: EN 1092-2/B (DIN 2501)
Face to Face Std.: EN 558 series 1 (DIN 3202 F1)
Flanges drilled: PN40 (DN15-DN150)
Pressure rating: PN40 (DN15-DN150)
Temperature range: 0°C to +120°C at max. working pressure

VARIATIONS: Can be supplied with regulating disc, non return disc and bronze trim.
With open/close indication.
All sizes available with flange drilling and pressure rating PN16.

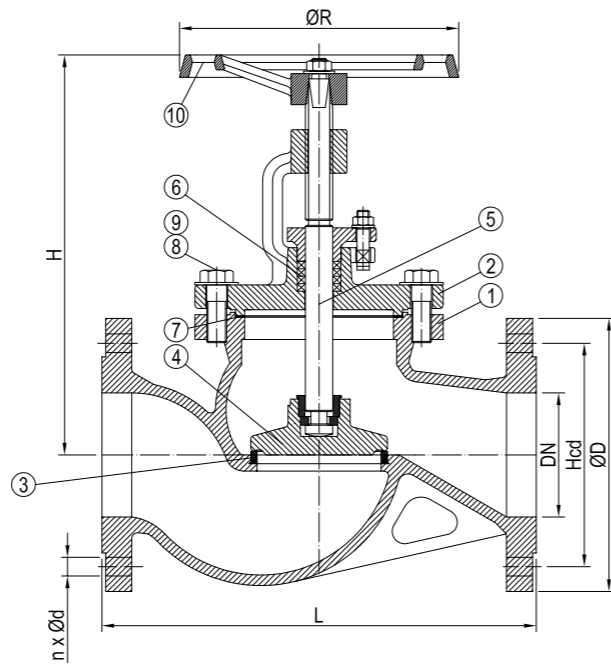
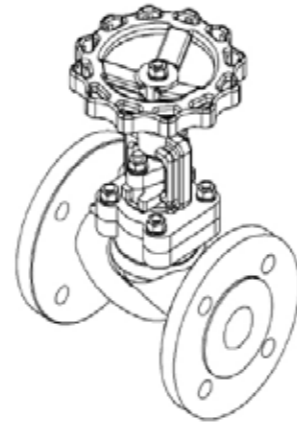

No	Part	Material	Code
1	Body	Cast Steel	GP240GH
2	Bonnet	Cast Steel	GP240GH
3	Seat	Stainless Steel	X5CrNi18-10
4	Disc(<=65) (>=80)	Stainless Steel Cast Steel	X20Cr13 GP240GH
5	Stem	Stainless Steel	X20Cr13
6	Gland Packing	Graphite	-
7	Bonnet Gasket	Graphite	-
8	Stud Bolt	Steel	-
9	Nut	Steel	-
10	Hand Wheel	Cast Iron	EN-GJL250

DN	n x ød	Hcd	øD	L	H	øR	Kg
15	4x14	65	95	130	165	120	4.0
20	4x14	75	105	150	165	120	4.5
25	4x14	85	115	160	175	140	5.0
32	4x18	100	140	180	180	140	7.0
40	4x18	110	150	200	220	160	11.0
50	4x18	125	165	230	230	160	13.0
65	8x18	145	185	290	245	180	19.0
80	8x18	160	200	310	295	200	25.0
100	8x22	190	235	350	330	225	37.0
125	8x26	220	270	400	365	250	61.0
150	8x26	250	300	480	420	300	84.0



GLOBE VALVE

ANGLE TYPE, FLANGED ENDS

467102/01
PN16/PN10

DESCRIPTION: Angled type, ductile cast iron body, metal seated screw down stop valve with rising stem, bolted bonnet. Raised face flanged connection.

APPLICATION: Aboard ships for hot and cold water, oil and steam.
Start/stop and throttling of: Sea water, water, steam and oils etc. Suitable as sea direct.

VARIATIONS: Can be supplied with regulating disc and non return disc.
Stainless steel trim. With open/close indication.

STANDARD & DESIGN:
Design Code: DIN 86251 STOP type (DIN 3356)
Inspection Std.: -
End Std.: EN 1092-2/B (DIN 2501)
Face to Face Std.: EN 558 series 8 (DIN 3202 F32)
Flanges drilled: PN16 (DN15-DN150)
PN10 (DN200-DN600)
PN16 (DN15-DN150)
PN10 (DN200-DN250)
PN6 (DN300-DN350)
PN4 (DN400-DN600)

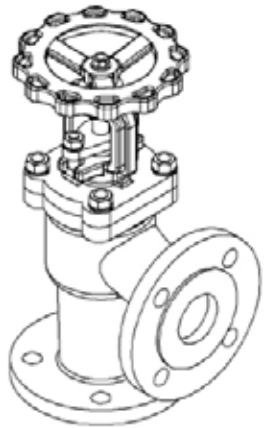

Pressure & Temperature ranges:

Bore	Working Pressure(Bar)	
	120°C	180°C
DN15-DN150	16	10
DN200-DN250	10	6
DN300-DN350	6	4
DN400-DN600	4	2

No	Part	Material	Code
1	Body	Nodular Cast Iron	EN-GJS400-18-LT
2	Bonnet	Nodular Cast Iron	EN-GJS400-18-LT
3	Seat	Bronze	CuSn5Zn5Pb5-C
4	Disc(<=65) (≥80)	Bronze Nodular Cast Iron	CuSn5Zn5Pb5-C EN-GJS400-18-LT
5	Stem	Brass	CuZn35Ni3Mn2AlPb
6	Gland Packing	Graphite	-
7	Bonnet Gasket	Graphite	-
8	Stud Bolt	Steel	-
9	Nut	Steel	-
10	Hand Wheel	Cast Iron	EN-GJL250

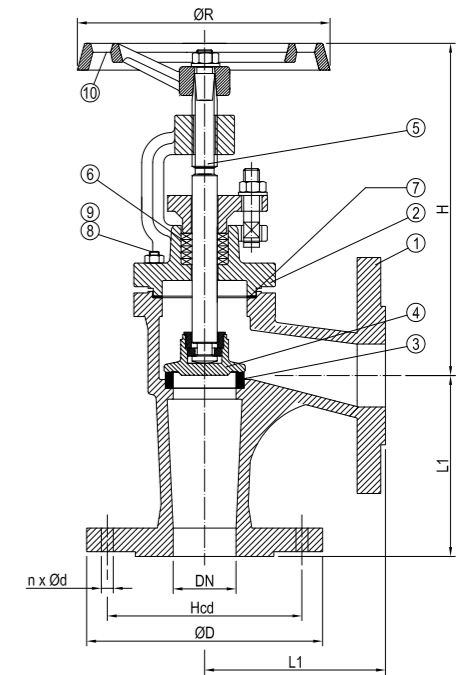

DN	n x ød	Hcd	øD	L1	H	øR	Kg
15	4x14	65	95	90	165	120	3.8
20	4x14	75	105	95	165	120	4.0
25	4x14	85	115	100	180	140	5.0
32	4x18	100	140	105	180	140	7.0
40	4x18	110	150	115	215	160	11.0
50	4x18	125	165	125	230	160	13.0
65	4x18	145	185	145	245	180	18.0
80	8x18	160	200	155	295	200	25.0
100	8x18	180	220	175	325	225	35.0
125	8x18	210	250	200	360	250	55.0
150	8x22	240	285	225	425	300	75.0
200	8x22	295	340	275	505	400	135.0
250	12x22	350	395	325	625	520	215.0
300	12x22	400	445	375	690	520	305.0
350	16x22	460	505	425	755	640	405.0
400	16x26	515	565	475	840	640	550.0
450	20x26	565	615	500	920	640	690.0



GLOBE VALVE

ANGLE TYPE, FLANGED ENDS

467152/51
PN16/PN10

DESCRIPTION: Angled type, grey cast iron body, metal seated screw down stop valve with rising stem, bolted bonnet. Raised face flanged connection.

APPLICATION: Aboard ships for hot and cold water and oil. Start/stop and throttling of: Sea water, water and oils etc.

VARIATIONS: Can be supplied with regulating disc and non return disc. Stainless steel trim. With open/close indication.

STANDARD & DESIGN:

Design Code: DIN 86251 STOP type (DIN 3356)
 Inspection Std.: -
 End Std.: EN 1092-2/B (DIN 2501)
 Face to Face Std.: EN 558 series 8 (DIN 3202 F32)
 Flanges drilled: PN16 (DN15-DN150)
 PN10 (DN200-DN600)
 PN16 (DN15-DN150)
 PN10 (DN200-DN250)
 PN6 (DN300-DN350)
 PN4 (DN400-DN600)
 Pressure rating:

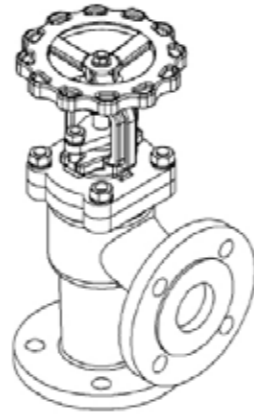

Pressure & Temperature ranges:

Bore	Working Pressure(Bar)	
	120°C	180°C
DN15-DN150	16	10
DN200-DN250	10	6
DN300-DN350	6	4
DN400-DN600	4	2

No	Part	Material	Code
1	Body	Cast Iron	EN-GJL250
2	Bonnet	Cast Iron	EN-GJL250
3	Seat	Bronze	CuSn5Zn5Pb5-C
4	Disc(≤65) (≥80)	Bronze Nodular Cast Iron	CuSn5Zn5Pb5-C EN-GJS400-18-LT
5	Stem	Brass	CuZn35Ni3Mn2AlPb
6	Gland Packing	Graphite	-
7	Bonnet Gasket	Graphite	-
8	Stud Bolt	Steel	-
9	Nut	Steel	-
10	Hand Wheel	Cast Iron	EN-GJL250

DN	n x ød	Hcd	øD	L1	H	øR	Kg
15	4x14	65	95	90	165	120	3.8
20	4x14	75	105	95	165	120	4.0
25	4x14	85	115	100	180	140	5.0
32	4x18	100	140	105	180	140	7.0
40	4x18	110	150	115	215	160	11.0
50	4x18	125	165	125	230	160	13.0
65	4x18	145	185	145	245	180	18.0
80	8x18	160	200	155	295	200	25.0
100	8x18	180	220	175	325	225	35.0
125	8x18	210	250	200	360	250	55.0
150	8x22	240	285	225	425	300	75.0
200	8x22	295	340	275	505	400	135.0
250	12x22	350	395	325	625	520	215.0
300	12x22	400	445	375	690	520	305.0
350	16x22	460	505	425	755	640	405.0
400	16x26	515	565	475	840	640	550.0
450	20x26	565	615	500	920	640	690.0

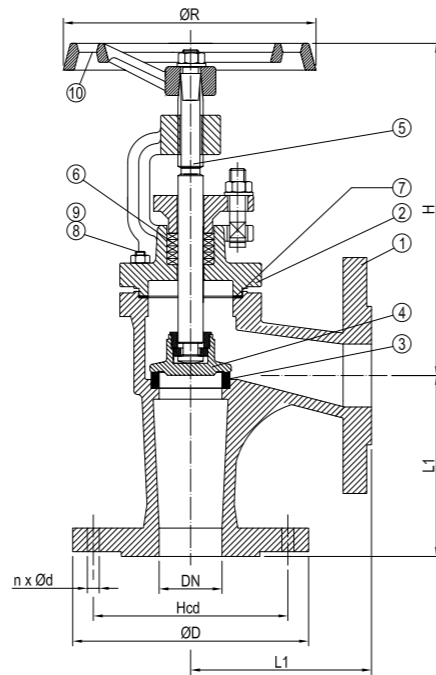

GLOBE VALVE

ANGLE TYPE, FLANGED ENDS

467164
PN40

DESCRIPTION: Angled type, cast steel body, metal seated screw down stop valve with rising stem, bolted bonnet. Raised face flanged connection.

APPLICATION:

Steam, cold and hot water, oil and gases and aggressive media, for higher temperatures and pressures. Start/stop and throttling of: Water, steam and oils etc.

STANDARD & DESIGN:

Design Code: DIN EN 13709 STOP Type (DIN 3356)
 Inspection Std.: -
 End Std.: EN 1092-1/B (DIN 2501)
 Face to Face Std.: EN 558 series 8 (DIN 3202 F32)
 Flanges drilled: PN40 (DN15-DN150)
 Pressure rating: PN40 (DN15-DN150)
 Temperature range: 0°C to +120°C at max. working pressure

VARIATIONS: Can be supplied with regulating disc and non return disc and bronze trim. With open/close indication. All sizes available with flange drilling and pressure rating PN16.

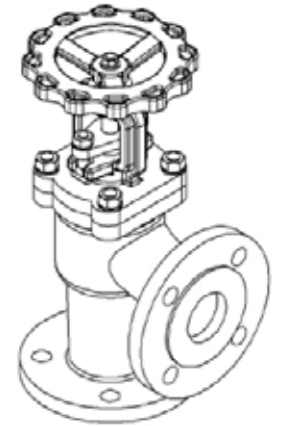

No	Part	Material	Code
1	Body	Cast Steel	GP240GH
2	Bonnet	Cast Steel	GP240GH
3	Seat	Stainless Steel	X5CrNi18-10
4	Disc(≤65) (≥80)	Stainless Steel Cast Steel	X20Cr13 GP240GH
5	Stem	Stainless Steel	X20Cr13
6	Gland Packing	Graphite	-
7	Bonnet Gasket	Graphite	-
8	Stud Bolt	Steel	-
9	Nut	Steel	-
10	Hand Wheel	Cast Iron	EN-GJL250

DN	n x ød	Hcd	øD	L1	H	øR	Kg
15	4x14	65	95	90	165	120	3.8
20	4x14	75	105	95	165	120	4.0
25	4x14	85	115	100	175	140	5.0
32	4x18	100	140	105	180	140	7.0
40	4x18	110	150	115	220	160	11.0
50	4x18	125	165	125	230	160	13.0
65	8x18	145	185	145	245	180	18.0
80	8x18	160	200	155	295	200	25.0
100	8x22	190	235	175	330	225	35.0
125	8x26	220	270	200	365	250	55.0
150	8x26	250	300	225	420	300	75.0

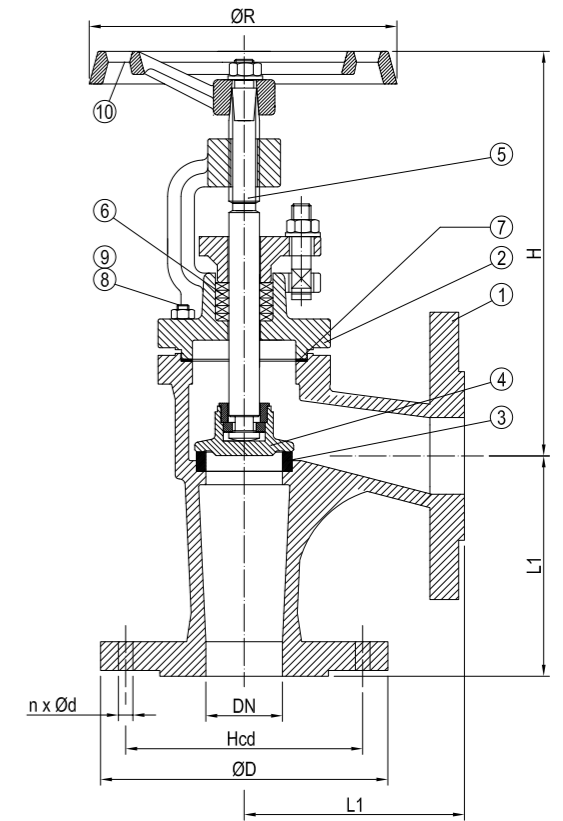



GLOBE VALVE

BELLOW SEALED, FLANGED ENDS

467003-104
PN25

DESCRIPTION: Straight type, nodular cast iron body. Metal seated screw down stop valve with non-rising bellow sealed stem. Bolted bonnet with open/closed indication. Raised face flanged.

APPLICATION: Hot and cold water plants, Steam plants, Neutral fluids. Start/stop and throttling of hot medias: Water, steam and oils etc. Also suitable for vacuum applications.

STANDARD & DESIGN:

Design Code: -
 Inspection Std.: EN 12266-1
 End Std.: EN 1092-2
 Face to Face Std.: EN 558-1
 Flanges drilled: PN25 (DN15-DN200)
 Pressure rating: PN25 (DN15-DN200)

VARIATIONS: Can be supplied with regulating disc. Angled type available.

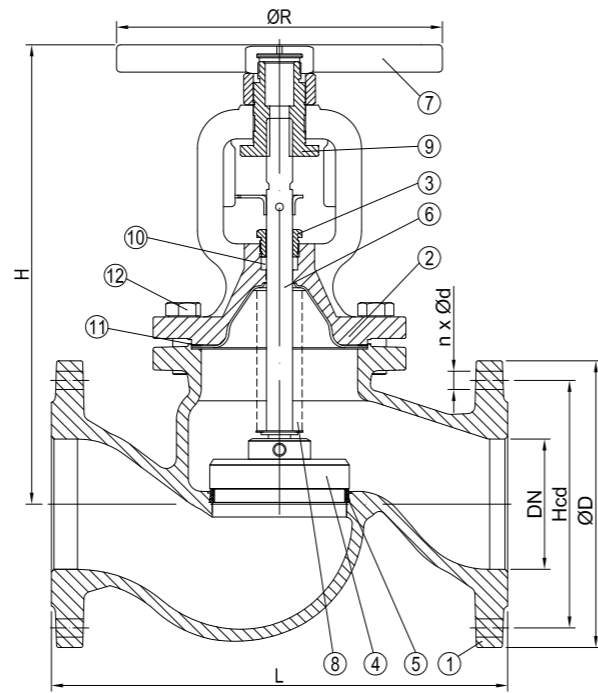
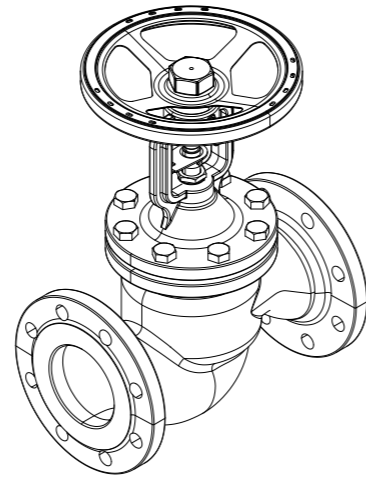
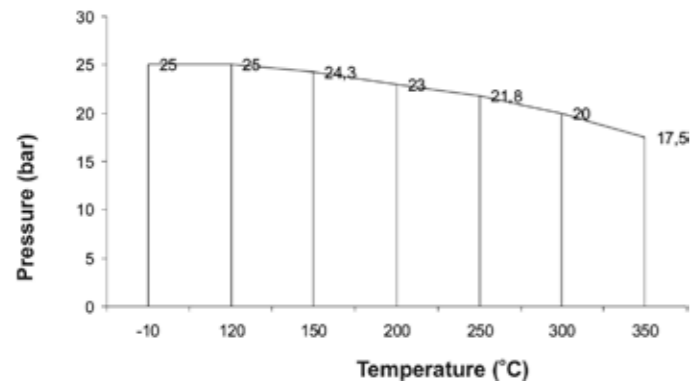

No	Part	Material	Code
1	Body	Nodular Cast Iron	EN-GJS400-18-LT
2	Bonnet	Nodular Cast Iron	EN-GJS400-18-LT
3	Gland	Free cutting Steel	11SMnPb30
4	Disc	Stainless Steel	X20Cr13 1.4021
5	Seat Ring	Stainless Steel	X12Cr13 1.4006
6	Stem	Stainless Steel	X20Cr13 1.4021
7	Handwheel	Steel	-
8	Bellow	Stainless Steel	X6CrNiMoTi-17-12-2
9	Sleeve	Free cutting Steel	11SMnPb30
10	Gland Packing	Graphite	-
11	Bonnet Gasket	Graphite+ CrNiSt	Gr+CrNiSt
12	Hexagon Bolt	304 Stainless Steel	A2-70

DN	n x ød	Hcd	øD	L	H	øR	Kg
15	4x14	65	95	130	178	125	3.2
20	4x14	75	105	150	178	125	3.9
25	4x14	85	115	160	193	125	4.9
32	4x19	100	140	180	201	125	6.5
40	4x19	110	150	200	224	150	9.0
50	4x19	125	165	230	228	150	11.0
65	8x19	145	185	290	270	175	15.8
80	8x19	160	200	310	295	200	24.3
100	8x23	190	235	350	325	250	35.0
125	8x28	220	270	400	380	300	49.0
150	8x28	250	300	480	427	400	76.0
200	12x28	310	360	600	569	500	130.5



GLOBE VALVE

BELLOW SEALED, FLANGED ENDS

467064-104
PN40

DESCRIPTION: Straight type, cast steel body. Metal seated screw down stop valve with non-rising bellow sealed stem. Bolted bonnet with open/closed indication. Raised face flanged.

APPLICATION: Hot and cold water plants, Steam plants, Neutral fluids. Start/stop and throttling of hot medias: Water, steam and oils etc. Also suitable for vacuum applications.

STANDARD & DESIGN:

Design Code: -
 Inspection Std.: EN 12266-1
 End Std.: EN 1092-1
 Face to Face Std.: EN 558-1
 Flanges drilled: PN40 (DN15-DN150)
 Pressure rating: PN40 (DN15-DN150)

VARIATIONS: Can be supplied with regulating disc. Angled type available.

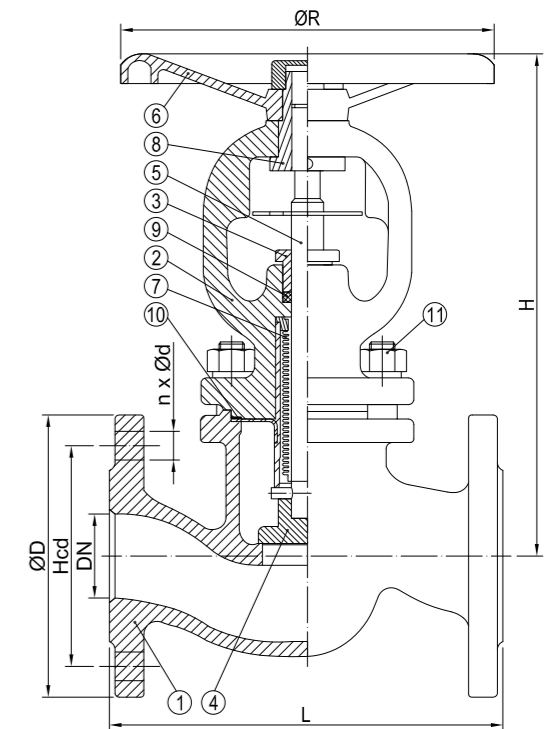
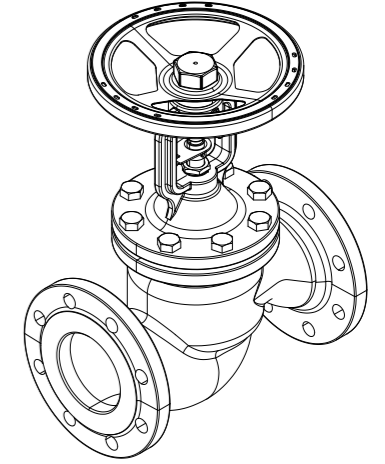
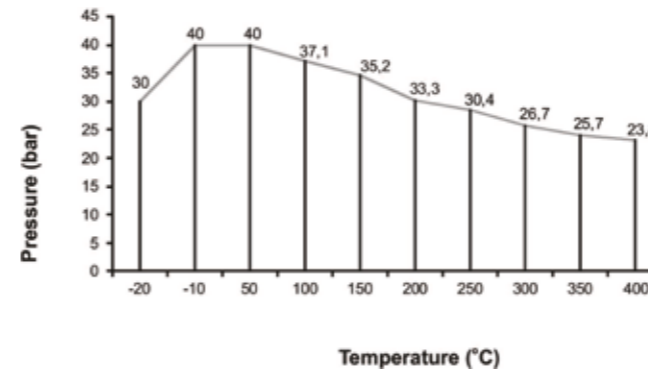

No	Part	Material	Code
1	Body	Cast Steel	GP240GH
2	Bonnet	Cast Steel	GP240GH
3	Gland	Free cutting Steel	11SMnPb30
4	Disc	Stainless Steel	X20Cr13 1.4021
5	Stem	Stainless Steel	X8CrNiS18-9 1.4305
6	Handwheel	Cast Iron	-
7	Bellow	Stainless Steel	X6CrNiTi-18-10
8	Sleeve	Free cutting Steel	11SMnPb30
9	Gland Packing	Graphite	-
10	Bonnet Gasket	Graphite+ CrNiSt	Gr+CrNiSt
11	Bolt and Nut	304 Stainless Steel	A2-70

DN	n x ød	Hcd	øD	L	H	øR	Kg
15	4x14	65	95	130	189	120	4.3
20	4x14	75	105	150	189	120	5.1
25	4x14	85	115	160	189	120	5.8
32	4x18	100	140	180	220	160	9.5
40	4x18	110	150	200	220	160	9.8
50	4x18	125	165	230	295	195	17.5
65	8x18	145	185	290	295	195	20.5
80	8x18	160	200	310	368	280	34.0
100	8x22	190	235	350	368	280	44.0
125	8x26	220	270	400	523	350	77.0
150	8x26	250	300	480	523	350	110.0



GLOBE VALVE

BELLOW SEALED, FLANGED ENDS

467094-104
PN40

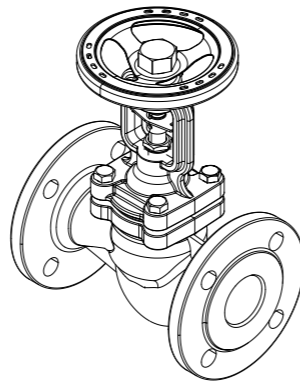

DESCRIPTION: Straight type, cast AISI 316 equivalent body. Metal seated screw down stop valve with bellow sealed non-rising stem, bolted bonnet. Raised face flanges.

APPLICATION: Start/stop and throttling of hot medias: Water, steam, oils and acidic media etc. Also suitable for vacuum applications.

VARIATIONS: Available as SDNR Valve. Available with Regulating disc. Angeled type available.

STANDARD & DESIGN:

Design Code: EN13709
 Inspection Std.: EN12266
 End Std.: EN1092-B1
 Face to Face Std.: EN558-1
 Flanges drilled: PN40(DN15-DN400)
 Pressure rating: PN40(DN15-DN400)
 Bellows: MSS-SP117

No	Part	Material	Code
1	Body	Stainless Steel	1.4408
2	Bonnet	Stainless Steel	1.4408
3	Gland	Stainless Steel	-
4	Disc	Stainless Steel	1.4401
5	Stem	Stainless Steel	1.4401
6	Pin	Stainless Steel	1.4401
7	Bellows	Stainless Steel	SS316L
8	Gasket	Graphite	-
9	Packing	Graphite	-
10	Bolt	Steel	A193 B8M
11	Nut	Steel	A194 8M
12	Pin	Stainless Steel	1.4401
13	Guide Piece	Stainless Steel	1.4401
14	Bolt	Steel	A193 B8M
15	Stem Nut	Nodular Cast Iron	GGG 40.3
16	Nut	Stainless Steel	-
17	Screw	Stainless Steel	1.4401
18	Balance Disc	Stainless Steel	1.4401
19	Split Ring	Stainless Steel	1.4401
20	Disc Cover	Stainless Steel	1.4401
21	Packing Gland	Stainless Steel	-
22	Bearing	Alloy Steel	
23	Bearing Cover	Carbon Steel	
24	Eye Bolt	Steel	A193 B8M
25	Nut	Steel	A194 8M
26	Handwheel	Carbon Steel	-

DN	n x ød	Hcd	øD	L	H	øR	Kg
15	4x14	65	95	130	200	120	4.0
20	4x14	75	105	150	202	140	4.6
25	4x14	85	115	160	205	140	5.5
32	4x18	100	140	180	208	140	7.5
40	4x18	110	150	200	230	160	9.0
50	4x18	125	165	230	235	160	11.1
65	8x18	145	185	290	245	180	17.9
80	8x18	160	200	310	267	200	24.2
100	8x22	190	235	350	350	250	37.0
125	8x26	220	270	400	380	250	59.8
150	8x26	250	300	480	410	350	80.2
200	12x30	320	375	600	550	500	174.0
250	12x33	385	450	730	730	500	267.0
300	16x33	450	515	850	800	500	378.0
350	16x36	510	580	980	950	600	700.0
400	16x39	585	660	1100	1030	600	1020.0

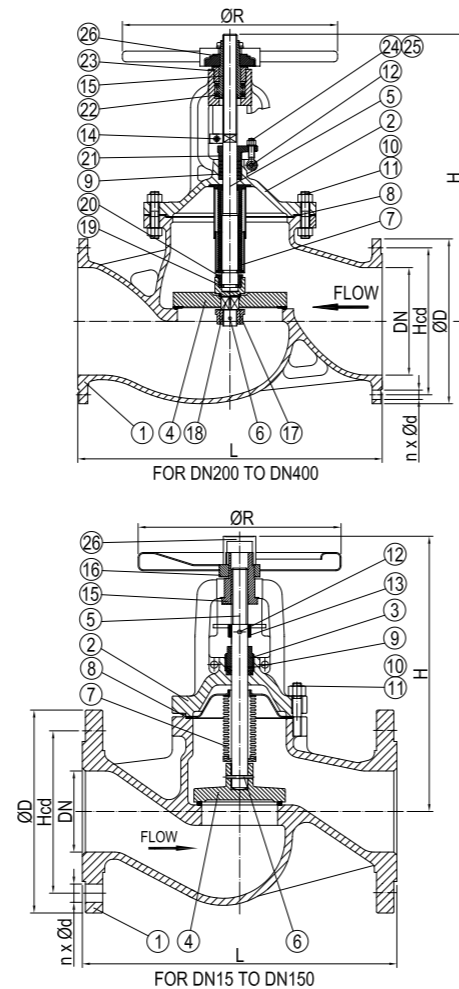

GLOBE VALVE

STRAIGHT, FLANGED ENDS

467065
PN63

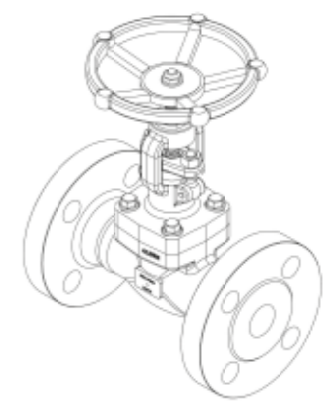

DESCRIPTION: Straight type, forged steel body stop valve, Stellite trim with rising stem and bolted bonnet. Raised face flanged.

APPLICATION: Start/stop and throttling of: Water, oils, steam, oils and aggressive/abrasive media etc.

STANDARD & DESIGN:

Design Code: BS 5352(DN15-DN40)
 EN 13709(DN50-DN150)
 Inspection Std.: EN 12266-1
 End Std.: EN 1092-1
 Face to Face Std.: EN 558-1
 Flanges drilled: PN63 (DN15-DN150)
 Pressure rating: PN63 (DN15-DN150)

VARIATIONS: Other dimensions and materials on request.

No	Part	Material	Code
1	Body (DN15-DN40)	Forged Steel	ASTM A105
	(DN50-DN150)	Cast Steel	ASTM A216-WCB
2	Bonnet(DN15-DN40)	Forged Steel	ASTM A105
	(DN50-DN150)	Cast Steel	ASTM A216-WCB
3	Disc (DN15-DN40)	Stainless Steel	ASTM A276-420
	(DN50-DN150)	Forged Steel	ASTM A105
4	Seat	Deposited Stellite	-
5	Stem (DN15-DN40)	Stainless Steel	ASTM A276-410
	(DN50-DN150)	Stainless Steel	ASTM A182-F6a
6	Packing	Graphite	-
7	Bonnet Gasket	Graphite	-
8	Stud Bolt	Steel	ASTM A193 Gr.B7
9	Nut	Steel	ASTM A194 Gr.2H
10	Eye Bolt	Steel	ASTM A194 Gr.2H
11	Gland Nut	Steel	ASTM A193 Gr.B8
12	Stem Nut(DN15-DN40)	Carbon Steel	1045
	(DN50-DN150)	Al-Bronze alloy	-
13	Handwheel(DN15-DN40)	Malleable Iron	ASTM A197
	(DN50-DN150)	Cast Iron	-
14	Back Seat	Deposited Stellite	-

DN	n x ød	Hcd	øD	L	H	øR	Kg
15	4x14	75	105	170	155	100	4.2
20	4x18	90	130	190	155	100	5.8
25	4x18	100	140	210	176	125	8.5
32	4x22	110	155	230	200	160	12.1
40	4x22	125	170	260	220	160	15.6
50	4x22	135	180	300	370	280	33.0
65	8x22	160	205	340	420	320	46.0
80	8x22	170	215	380	460	400	65.0
100	8x26	200	250	430	480	400	95.0
150	8x33	280	345	550	600	500	107.0

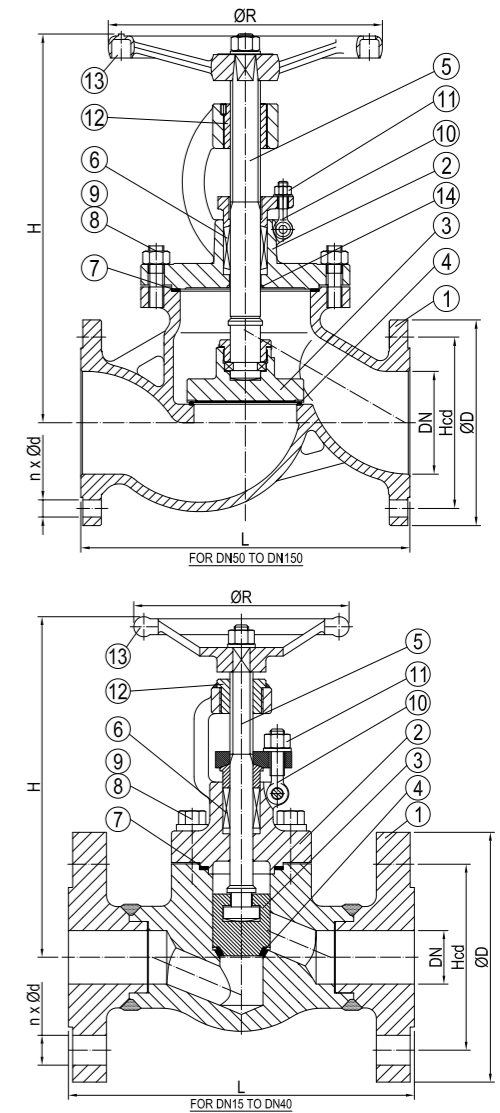



GLOBE VALVE

STRAIGHT, FLANGED ENDS

467092
PN16

DESCRIPTION: Straight type, AISI 316 equivalent body, metal seated screw down stop valve with rising stem, bolted bonnet. Raised face flanged.

APPLICATION: Start/stop and throttling of: Water, steam, oils, etc.

STANDARD & DESIGN:

Design Code: ASME B16.34
 Inspection Std.: EN 12266-1
 End Std.: DIN 2633
 Face to Face Std.: DIN 3202-F1
 Flanges drilled: PN16 (DN15-DN200)
 Pressure rating: PN16 (DN15-DN200)

VARIATIONS: Can be supplied with regulating disc and non return disc. PTFE soft seal available.

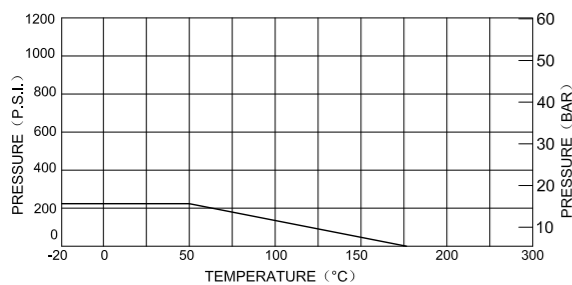
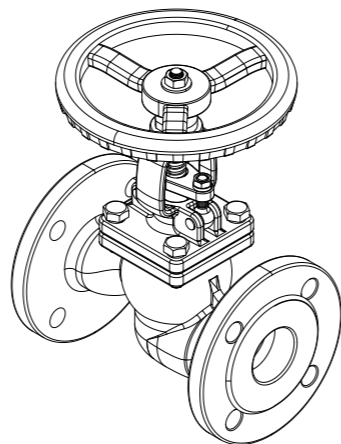

No	Part	Material	Code
1	Body	Stainless Steel	1.4408
2	Bonnet	Stainless Steel	1.4408
3	Gland	Stainless Steel	1.4308
4	Disc	Stainless Steel	1.4408
5	Disc Cover	Stainless Steel	1.4408
6	Stem	Stainless Steel	SUS 316
7	Gasket	PTFE/304+GRAPHITE	-
8	Gland Packing	PTFE	-
9	Bolt	Stainless Steel	SUS 304
10	Nut	Stainless Steel	SUS 304
11	Hinge Pin	Stainless Steel	SUS 304
12	Stem Bushing	PTFE	-
13	Eye Bolt	Stainless Steel	SUS 304
14	Gland Nut	Stainless Steel	SUS 304
15	Yoke Sleeve	Bronze	CuSn5ZnPB5-C
16	Spring Washers	Stainless Steel	SUS 304
17	Nut	Stainless Steel	SUS 304
18	Name Plate	Stainless Steel	SUS 304
19	Hand Wheel	Cast Iron	FCD 400

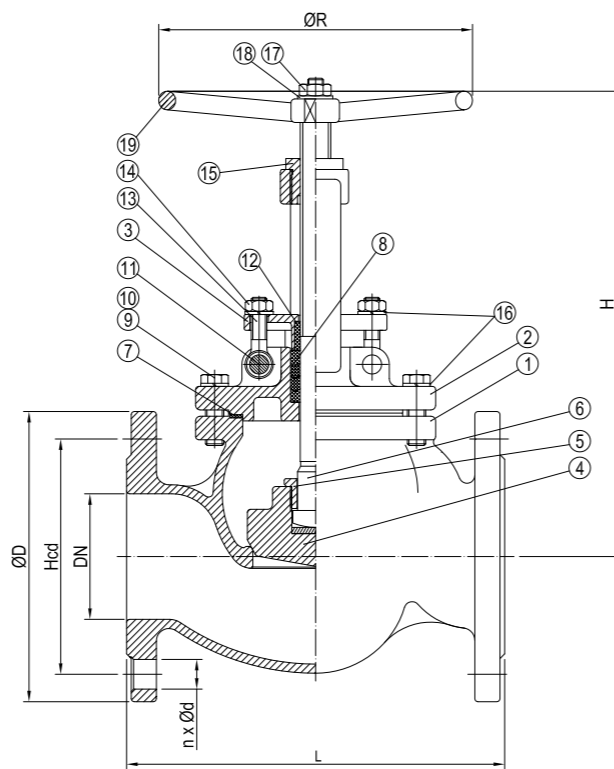

DN	n x ød	Hcd	øD	L	H	øR	Kg
15	4x14	65	95	130	186	140	3.3
20	4x14	75	105	150	186	140	4.3
25	4x14	85	115	160	212	140	5.2
32	4x18	100	140	180	243	160	7.7
40	4x18	110	150	200	246	160	8.5
50	4x18	125	165	230	252	200	12.2
65	4x18	145	185	290	308	200	16.3
80	8x18	160	200	310	327	250	21.3
100	8x18	180	220	350	384	250	28.2
125	8x18	210	250	400	484	300	46.6
150	8x22	240	285	480	547	350	60.8
200	12x22	295	340	600	669	350	98.5



GLOBE VALVE

STRAIGHT, FLANGED ENDS

471762
PN16

DESCRIPTION: Straight type cast steel body with combined stop and check valve function, Stellite trim. With gearbox and open/closed indication. Raised face flanged.

APPLICATION: Start/stop/check and throttling of: Water, steam, oils and aggressive/abrasive media etc.

STANDARD & DESIGN:

Design Code: EN 13709
 Inspection Std.: EN 12266-1
 End Std.: Raised face flange ends acc. to EN 1092-1
 Face to Face Std.: EN 558-1
 Flanges drilled: PN16 (DN100-DN400)
 Pressure rating: PN16(DN100-DN400)

VARIATIONS: Other dimensions and materials on request.

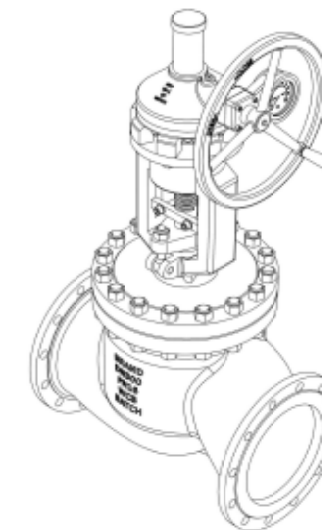

No	Part	Material	Code
1	Body	Cast Steel	ASTM A216-WCB
2	Bonnet	Cast Steel	ASTM A216-WCB
3	Disc	Forged Steel	ASTM A105
4	Secondary Disc	Stainless Steel	ASTM A276-420
5	Seat	Deposited Stellite	-
6	Stem	Forged Steel	ASTM A182-F6a
7	Gasket	Graphite/304	-
8	Back Seat Bushing	Steel	ASTM A276-410
9	Packing	Graphite	-
10	Bonnet Bolt	Steel	ASTM A193 Gr.B7
11	Bonnet Bolt Nut	Steel	ASTM A194 Gr.2H
12	Conical Gear Actuator	-	-

DN	n x ød	Hcd	øD	L	H	Kg
100	8x18	180	220	350	-	-
150	8x22	240	285	480	-	-
200	12x22	295	340	600	-	-
250	12x26	355	405	650	740	255
300	12x26	410	460	750	830	429
350	16x26	470	520	850	900	640
400	16x30	525	580	950	1150	900

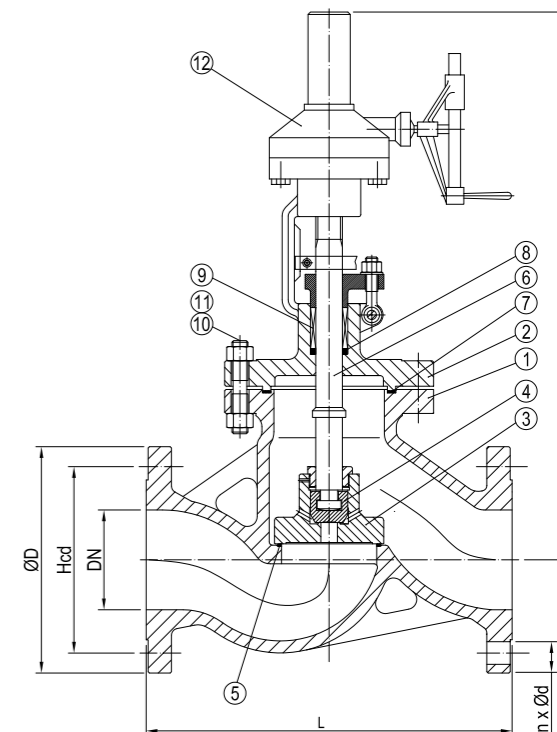



PRESSURE GAUGE VALVE

490515
PN100

DESCRIPTION: Fitting for pressure gauge mounting, combined with open/close functionality. Male BSPP threaded.

APPLICATION: Connection of manometer.

STANDARD & DESIGN:

Design Code: -
 Inspection Std.: -
 End Std.: BSP
 Face to Face Std.: -
 Pressure rating: PN100(DN8-DN15)

VARIATIONS: Available with locked gland nut. NPT threaded. AISI 304 and 316 for PN400.

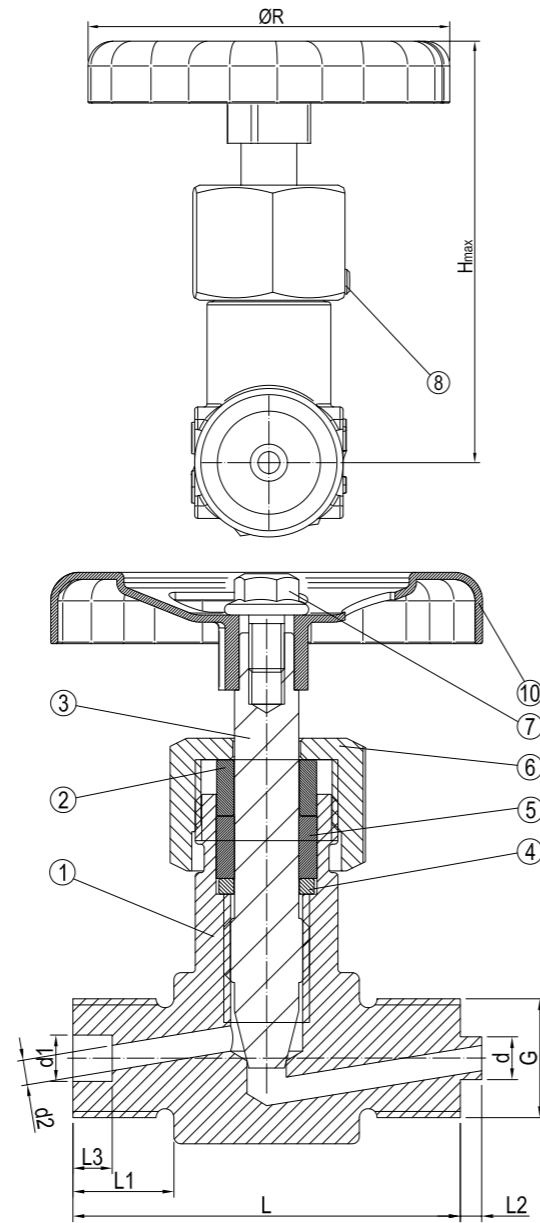
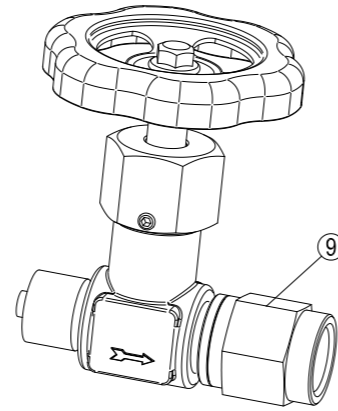

No	Part	Material	Code
1	Body	Brass	CW 614N
2	Gland	Brass	CW 614N
3	Stem	Brass	CW 614N
4	Washer	Brass	CW 614N
5	Gland Packing	Graphite	-
6	Gland Nut	Brass	CW 614N
7	Flange Screw	Steel	-
8	Set Screw	Steel	-
9	Adapter Piece	Brass	CW 614N
10	Handwheel	Steel	-

DN	G(Inch)	L	L1	L2	L3	H _{max}	d	d1	d2	øR	Kg
8	1/4	50	13	3	6	95	6	6.5	3.5	60	0.3
10	3/8	54	15	3	6	95	6	6.5	3.5	60	0.3
15	1/2	64	20	5	6	95	6	6.5	3.5	60	0.4



PRESSURE GAUGE VALVE WITH TEST FLANGE

490615
PN100

DESCRIPTION: Fitting for pressure gauge mounting, combined with open/close functionality. Male BSPP threaded. With test flange.

APPLICATION: Connection of manometer, including fitting for one test/calibration unit.

STANDARD & DESIGN:

Design Code: -
 Inspection Std.: -
 End Std.: BSP
 Face to Face Std.: -
 Pressure rating: PN100(DN8-DN15)

VARIATIONS: Available with locked gland nut. NPT threaded. AISI 304 and 316 for PN400.

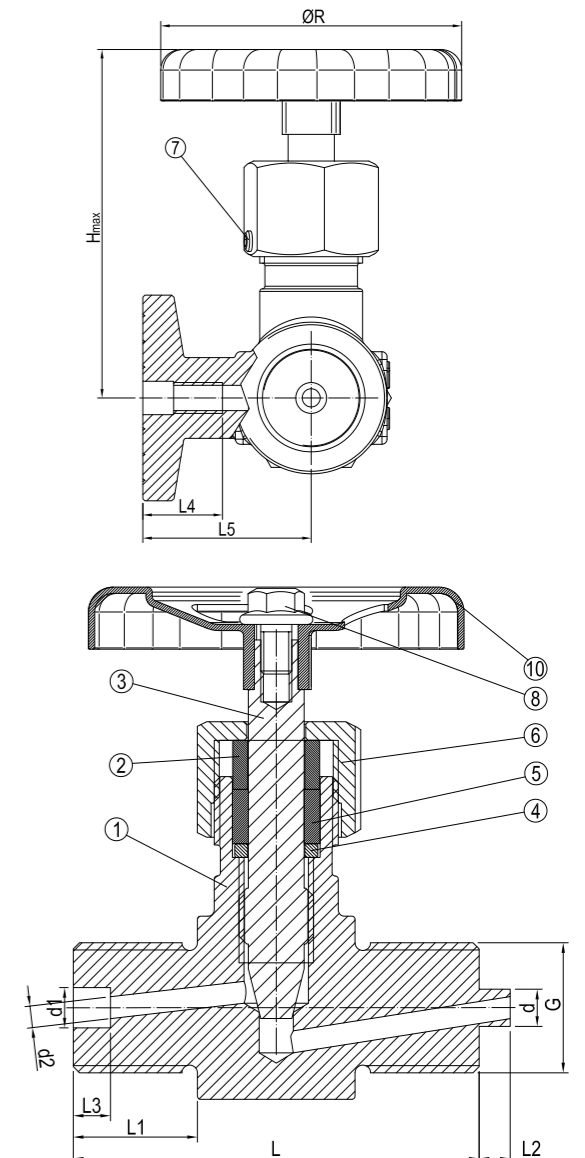
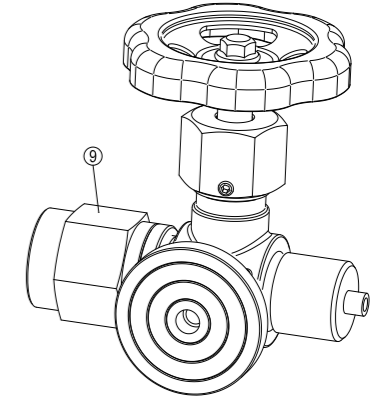

No	Part	Material	Code
1	Body	Brass	CW 614N
2	Gland	Brass	CW 614N
3	Stem	Brass	CW 614N
4	Washer	Brass	CW 614N
5	Gland Packing	Graphite	-
6	Gland Nut	Brass	CW 614N
7	Set Screw	Steel	-
8	Flange Screw	Steel	-
9	Adapter Piece	Brass	CW 614N
10	Handwheel	Steel	-

DN	G(Inch)	L	L1	L2	L3	L4	L5	H _{max}	d	d1	d2	øR	Kg
8	1/4	50	13	3	6	15	31	95	6	6.5	3.5	60	0.4
10	3/8	54	15	3	6	15	31	95	6	6.5	3.5	60	0.4
15	1/2	64	20	5	6	15	34	95	6	6.5	3.5	60	0.5



DIAPHRAGM VALVES

For shut off purposes. Often used for compressed air systems and applications with particules in the fluid.
Available with threaded or flanged end connections.
Available with various materials in the diaphragm, and with hard rubber lining inside the valve.



DIAPHRAGM VALVE

S2K RISING HW TYPE, THREADED ENDS

469052
PN16

DESCRIPTION: Straight type with NBR (std.) diaphragm, grey cast iron body. Rising stem with open/close indication, bolted bonnet. Female BSPP threaded ends.

APPLICATION: Wide range media valve for start/stop and throttling. The non lined type is commonly used for compressed air and non corrosive slurries. Also for vacuum.

STANDARD & DESIGN:

Design Code: BS EN 13397
 Inspection Std.: BS EN 12266-1 / BS:6755-1
 End Std.: BS 21
 Face to Face Std.: -
 Pressure rating: PN16(DN15-DN50)

VARIATIONS: Diaphragm of EPDM, Natural rubber. With har rubber lining.

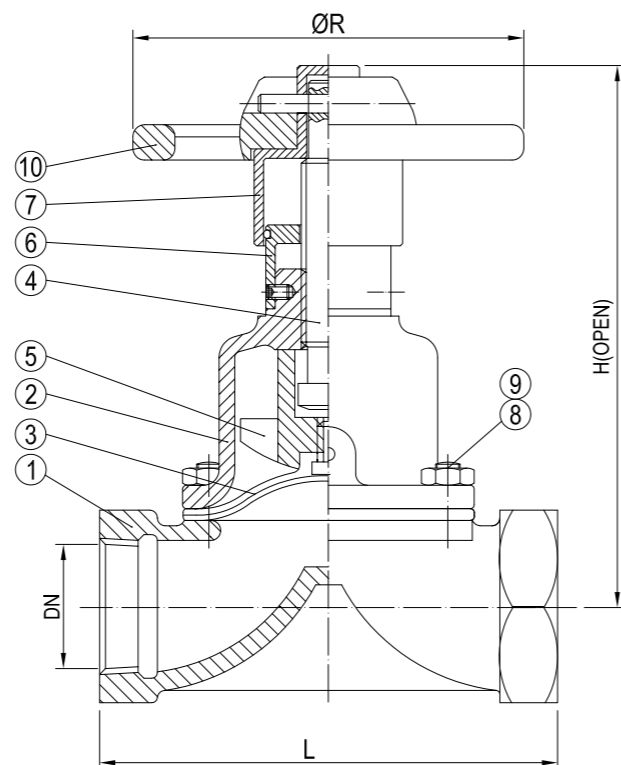
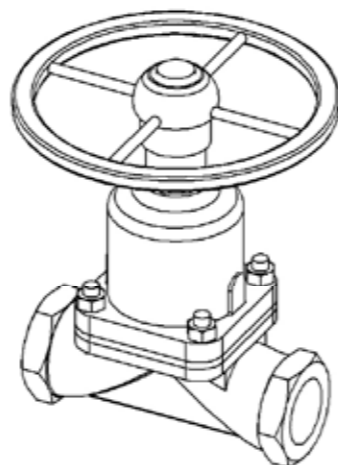

No	Part	Material	Code
1	Body	Cast Iron	ASTM A 126 CLASS B
2	Bonnet	Cast Iron	ASTM A 126 CLASS B
3	Diaphragm	Natural/EPDM/Butyl	-
4	Stem	Stainless Steel	ASTM A 276-410
5	Compressor	Cast Steel	ASTM A 216 Gr.WCB
6	Indicator	Cast Iron	-
7	Indicator Cap	Cast Iron	-
8	Stud Bolt	Steel	ASTM A 193 Gr.B7
9	Nut	Steel	ASTM A 193 Gr.B7
10	Handwheel	Cast Iron	ASTM A 126 CLASS B

DN	Inch	L	H	øR	Kg
15	1/2	64	105	80	0.9
20	3/4	83	115	80	1.8
25	1	108	132	120	3.0
32	1 1/4	121	140	120	3.2
40	1 1/2	140	180	180	3.5
50	2	165	210	180	6.5



DIAPHRAGM VALVE

S2K RISING HW TYPE, FLANGED ENDS

469252/51
PN16/PN10/PN6

DESCRIPTION: Straight type with NBR (std.) diaphragm, grey cast iron body. Rising stem with open/close indication, bolted bonnet. Flat face flanged connection.

APPLICATION: Wide range media valve for start/stop and throttling. The lined type is commonly used for aggressive medias and slurries. Also for vacuum.

STANDARD & DESIGN:

Design Code: BS EN 13397 / BS:5156
 Inspection Std.: BS EN 12266-1 / BS:6755-1
 End Std.: BS EN 1092
 Face to Face Std.: EN 558, Series 1(DIN 3202 F1)
 Pressure rating: PN16(DN15-DN50)
 PN10(DN65-DN150)
 PN6(DN200-DN300)
 Flanges Drilled: PN16(DN15-DN50)
 PN10(DN65-DN300)

VARIATIONS: Diaphragm of EPDM, Natural rubber. With har rubber lining.

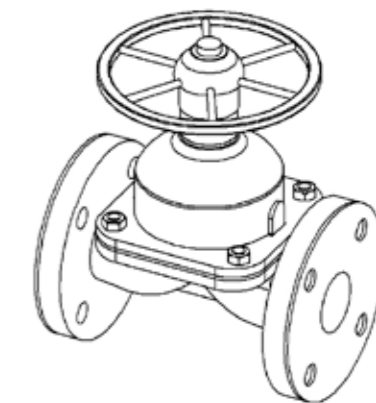

Note: Sizes DN250 and DN300 in slightly different design with non rising handwheel.

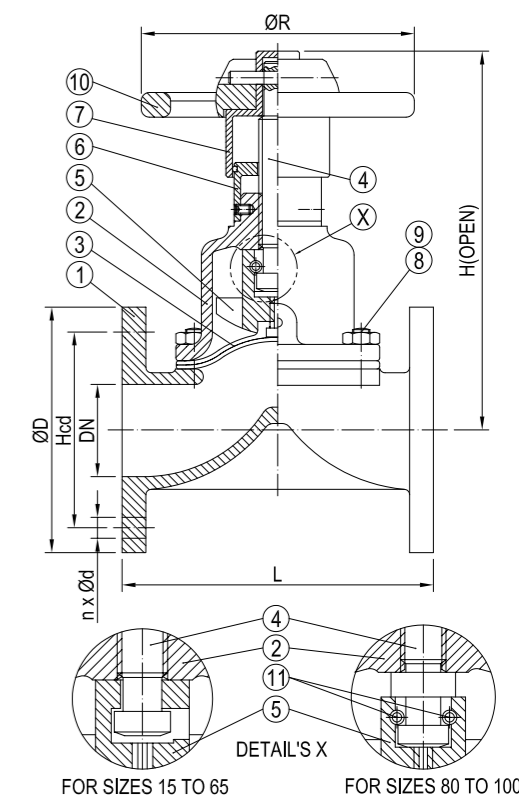

No	Part	Material	Code
1	Body	Cast Iron	ASTM A 126 CLASS B
2	Bonnet	Cast Iron	ASTM A 126 CLASS B
3	Diaphragm	Natural/EPDM/Butyl	-
4	Stem	Stainless Steel	ASTM A 276 TYPE 410
5	Compressor	Cast Steel	ASTM A 216 Gr.WCB
6	Indicator	Cast Iron	-
7	Indicator Cap	Cast Iron	-
8	Stud Bolt	Steel	ASTM A 193 Gr.B7
9	Nut	Steel	ASTM A 193 Gr.B7
10	Handwheel	Cast Iron	-
11	Spring Dowel Sleeve	Spring Steel	-

DN	n x ød	Hcd	øD	L	H	øR	Kg
15	4x14	65	95	130	105	80	2.8
20	4x14	75	105	150	115	80	3.1
25	4x14	85	115	160	132	120	3.8
32	4x18	100	140	180	140	120	5.7
40	4x18	110	150	200	180	180	7.3
50	4x18	125	165	230	210	180	16.0
65	4x18	145	185	290	235	180	19.0
80	8x18	160	200	310	305	250	26.0
100	8x18	180	220	350	340	250	41.0
125	8x18	210	250	400	420	315	67.0
150	8x22	240	285	480	490	360	103.0
200	8x22	295	340	600	645	470	187.0
250	12x22	350	395	730	699	587	275.0
300	12x22	400	445	850	825	690	480.0



DIAPHRAGM VALVE

469651
PN10/PN6

G2K RISING HW TYPE, FLANGED ENDS

DESCRIPTION: Straight through (full flow) type with NBR (std.) diaphragm, grey cast iron body. Rising stem with open/close indication, bolted bonnet. Flat face flanged connection.

APPLICATION: Wide range media valve for start/stop and throttling. The non lined type is commonly used for compressed air and non corrosive slurries. Also for vacuum.

STANDARD & DESIGN:

Design Code: BS EN 13397 / BS:5156
 Inspection Std.: BS EN 12266-1 / BS:6755-1
 End Std.: BS EN 1092
 Face to Face Std.: EN 558, Series 1 (DIN 3202 F1)
 Pressure rating: PN10(DN15-DN125)
 PN6(DN150-DN300)
 Flanges Drilled: PN10(DN15-DN300)

VARIATIONS: Diaphragm of EPDM, Natural rubber. With har rubber lining.

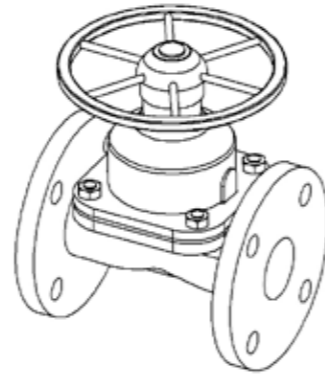

Note: Sizes DN250 and DN300 in slightly different design with non rising handwheel.

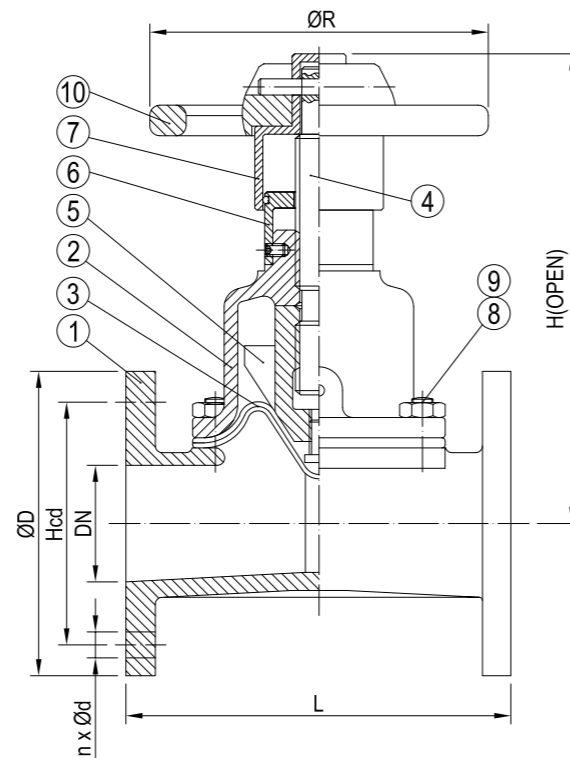

No	Part	Material	Code
1	Body	Cast Iron	ASTM A 126 CLASS B
2	Bonnet	Cast Iron	ASTM A 126 CLASS B
3	Diaphragm	Natural/EPDM/Butyl	-
4	Stem	Stainless Steel	ASTM A 276 TYPE 410
5	Compressor	Cast Iron	ASTM A 216 CLASS B
6	Indicator	Cast Iron	-
7	Indicator Cap	Cast Iron	-
8	Stud Bolt	Steel	ASTM A 193 Gr.B7
9	Nut	Steel	ASTM A 193 Gr.B7
10	Handwheel	Cast Iron	-

DN	n x ød	Hcd	øD	L	H	øR	Kg
15	4x14	65	95	130	105	80	3.1
20	4x14	75	105	150	115	80	3.5
25	4x14	85	115	160	135	120	4.5
32	4x18	100	140	180	135	120	5.7
40	4x18	110	150	200	135	120	6.0
50	4x18	125	165	230	175	180	10.5
65	4x18	145	185	290	200	180	15.5
80	8x18	160	200	310	260	250	26.0
100	8x18	180	220	350	275	250	33.0
125	8x18	210	250	400	340	315	57.0
150	8x22	240	285	480	440	360	87.0
200	8x22	295	340	600	495	470	146.0
250	12x22	350	395	730	670	587	192.0
300	12x22	400	445	850	795	587	335.0



DIAPHRAGM VALVE

469751
PN10/PN6

G2K RISING HW TYPE, FLANGED ENDS

DESCRIPTION: Short length, straight through (full flow) type with NBR (std.) diaphragm, grey cast iron. Rising stem with open/close indication, bolted bonnet. Flat face flanged connection.

APPLICATION: Wide range media valve for start/stop and throttling. The non lined type is commonly used for compressed air and non corrosive slurries. Also for vacuum.

STANDARD & DESIGN:

Design Code: BS EN 13397 / BS:5156
 Inspection Std.: BS EN 12266-1 / BS:6755-1
 End Std.: BS EN 1092
 Face to Face Std.: EN 558, Series 7 (BS 5156)
 Pressure rating: PN10(DN15-DN125)
 PN6(DN150-DN300)
 Flanges Drilled: PN10(DN15-DN300)

VARIATIONS: Diaphragm of EPDM, Natural rubber. With har rubber lining.

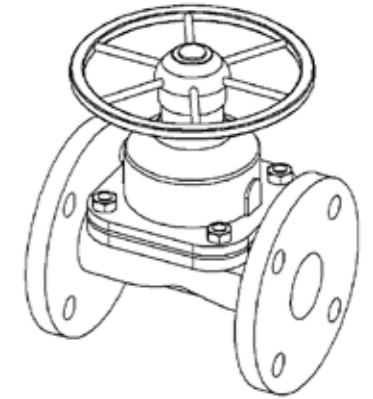

Note: Sizes DN250 and DN300 in slightly different design with non rising handwheel.

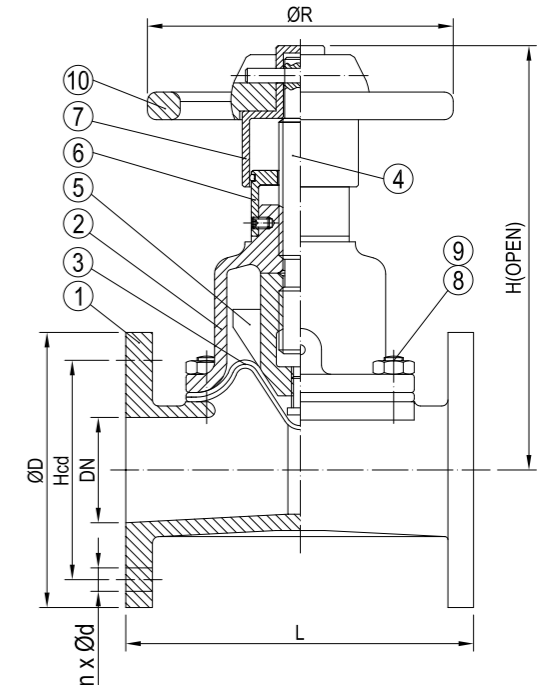

No	Part	Material	Code
1	Body	Cast Iron	ASTM A 126 CLASS B
2	Bonnet	Cast Iron	ASTM A 126 CLASS B
3	Diaphragm	Natural/EPDM/Butyl	-
4	Stem	Stainless Steel	ASTM A 276 TYPE 410
5	Compressor	Cast Iron	ASTM A 216 CLASS B
6	Indicator	Cast Iron	-
7	Indicator Cap	Cast Iron	-
8	Stud Bolt	Steel	ASTM A 193 Gr.B7
9	Nut	Steel	ASTM A 193 Gr.B7
10	Handwheel	Cast Iron	-

DN	n x ød	Hcd	øD	L	H	øR	Kg
15	4x14	65	95	108	105	80	2.8
20	4x14	75	105	117	115	80	3.3
25	4x14	85	115	127	135	120	4.2
32	4x18	100	140	146	135	120	4.8
40	4x18	110	150	159	135	120	5.5
50	4x18	125	165	190	175	180	10.0
65	4x18	145	185	216	200	180	15.0
80	8x18	160	200	254	260	250	25.0
100	8x18	180	220	305	275	250	32.0
125	8x18	210	250	356	340	315	55.0
150	8x22	240	285	406	440	360	85.0
200	8x22	295	340	521	495	470	144.0
250	12x22	350	395	635	670	587	188.0
300	12x22	400	445	749	795	587	330.0



STORM FLAP VALVES & CHECK VALVES

Used to avoid flow in both directions. Often placed in connection with pumps.
Available with threaded, flanged or weld end connections. Also available in wafer version to be mounted between flanges.
Metal to metal sealing or soft sealing.



STORM FLAP VALVE

ANGLE TYPE, FLANGED ENDS

159101
PN4

DESCRIPTION: Angled type closable check valve. Nodular cast iron body. Soft sealing disc. Flat face PN10 flanged. Different inlet/outlet diameter.

APPLICATION: Sanitary piping systems which have a ship's side exit. Ship side valve for discharge from various sanitary systems. Preventing sea water from entering the piping system. Manually closable at e.g. dry docking.

STANDARD & DESIGN:

Design Code: DIN HNA Sr 6 Form B - with closing device and handwheel.
 Inspection Std.: -
 End Std.: EN 1092/A (DIN 2501)
 Face to Face Std.: DIN HNA Sr 6
 Flanges drilled: PN10 (DN50-DN250)
 Pressure rating: PN4 (DN50-DN250)
 Temperature Range: -10°C to +60°C

VARIATIONS: With open/close indication.
 Other dimensions and materials on request.

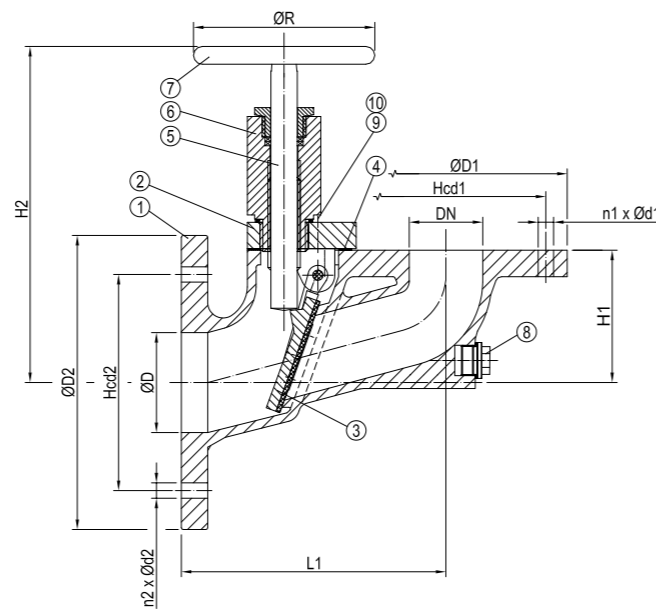
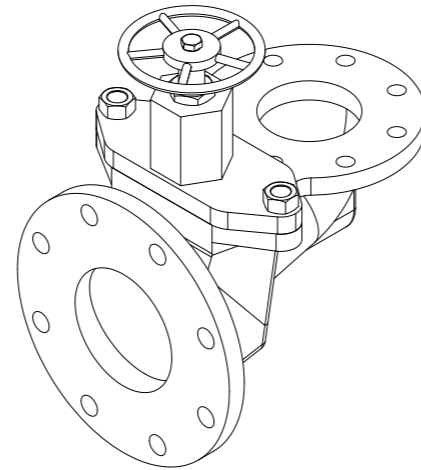

No	Part	Material	Code
1	Body	Nodular Cast Iron	EN-GJS400-18-LT
2	Bonnet	Nodular Cast Iron	EN-GJS400-18-LT
3	Disc with Sealing	Bronze +NBR	Rg5 + NBR
4	Bonnet Gasket	NBR	-
5	Stem	Brass	CuZn39Pb3
6	Stem Nut	Brass	CuZn39Pb3
7	Handwheel	Cast Iron	EN-GJL250
8	Plug	Brass	CuZn39Pb3
9	Stud Bolts	Steel	-
10	Nut	Steel	-

DN	n1xØd1	Hcd1	ØD1	n2xØd2	Hcd2	ØD2	ØD	L1	H1	H2	ØR	Kg
50	4x18	125	165	8x18	160	200	70	180	90	260	140	12
65	4x18	145	185	8x18	180	220	85	200	100	270	140	14
80	8x18	160	200	8x18	210	250	100	215	108	290	140	20
100	8x18	180	220	8x22	240	285	130	250	130	305	140	25
125	8x18	210	250	8x22	270	315	158	290	152	330	160	36
150	8x22	240	285	8x22	295	340	190	330	176	260	160	43
200	8x22	295	340	12x22	350	395	240	425	180	350	160	72



STORM FLAP VALVE

ANGLE TYPE, FLANGED ENDS

159121
PN4

DESCRIPTION: Angled type closable check valve. Rg5 body. Soft sealing disc. Flat face PN10 flanged. Different inlet/outlet diameter.

APPLICATION: Sanitary piping systems which have a ship's side exit. Ship side valve for discharge from various sanitary systems. Preventing sea water from entering the piping system. Manually closable at e.g. dry docking.

STANDARD & DESIGN:

Design Code: DIN HNA Sr 6 Form B - with closing device and handwheel.
 Inspection Std.: -
 End Std.: EN 1092-3/A (DIN 2501)
 Face to Face Std.: DIN HNA Sr 6
 Flanges drilled: PN10 (DN50-DN200)
 Pressure rating: PN4 (DN50-DN200)
 Temperature Range: -10°C to +60°C

VARIATIONS: With open/close indication.
 RG10 body
 Other dimensions and materials on request.

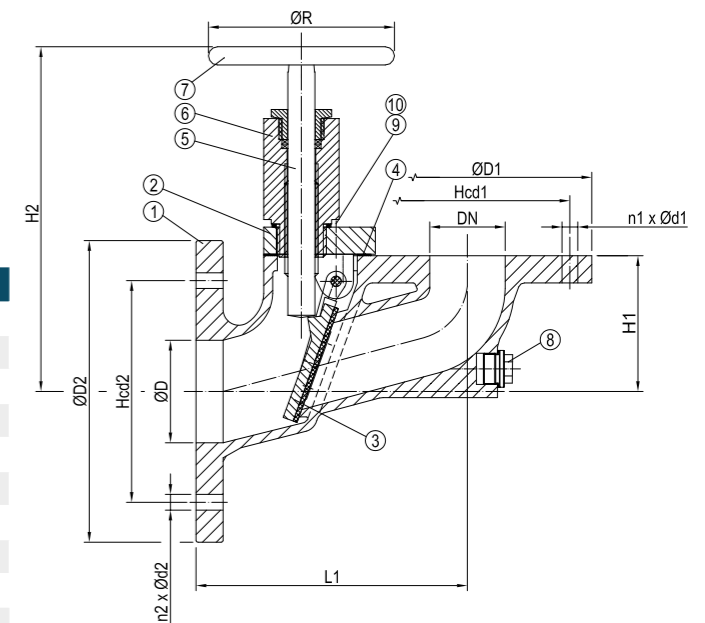
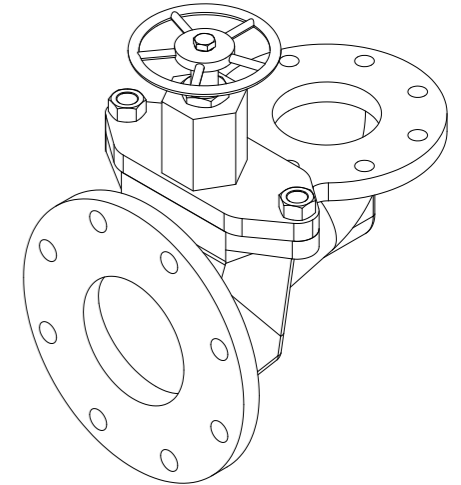

No	Part	Material	Code
1	Body	Bronze	CuSn5ZnPb5-C
2	Bonnet	Bronze	CuSn5ZnPb5-C
3	Disc with Sealing	Bronze +NBR	Rg5 + NBR
4	Bonnet Gasket	NBR	-
5	Stem	Brass	CuZn39Pb3
6	Stem Nut	Brass	CuZn39Pb3
7	Handwheel	Cast Iron	EN-GJL250
8	Plug	Stainless Steel	A2(AISI 304)
9	Stud Bolts	Stainless Steel	A2(AISI 304)
10	Nut	Stainless Steel	A2(AISI 304)

DN	n1xØd1	Hcd1	ØD1	n2xØd2	Hcd2	ØD2	ØD	L1	H1	H2	ØR	Kg
50	4x18	125	165	8x18	160	200	70	180	90	260	140	14
65	4x18	145	185	8x18	180	220	85	200	100	270	140	16
80	8x18	160	200	8x18	210	250	100	215	108	290	140	22
100	8x18	180	220	8x22	240	285	130	250	130	305	140	28
125	8x18	210	250	8x22	270	315	158	290	152	330	160	40
150	8x22	240	285	8x22	295	340	190	330	176	350	160	50
200	8x22	295	340	12x22	350	395	240	425	180	350	160	80



STORM FLAP VALVE

ANGLE TYPE, FLANGED ENDS

159161
PN4

DESCRIPTION: Angled type closable check valve. Cast steel body. Soft sealing disc. Flat face PN10 Flanged. Different inlet/outlet diameter.

APPLICATION: Sanitary piping systems which have a ship's side exit. Ship side valve for discharge from various sanitary systems. Preventing sea water from entering the piping system. Manually closable at e.g. dry docking.

STANDARD & DESIGN:

Design Code: DIN HNA Sr 6 Form B - with closing device and handwheel.
 Inspection Std.: -
 End Std.: EN 1092/A (DIN 2501)
 Face to Face Std.: DIN HNA Sr 6
 Flanges drilled: PN10 (DN50-DN250)
 Pressure rating: PN4 (DN50-DN250)
 Temperature Range: -10°C to +60°C

VARIATIONS: With open/close indication. Other dimensions and materials on request.

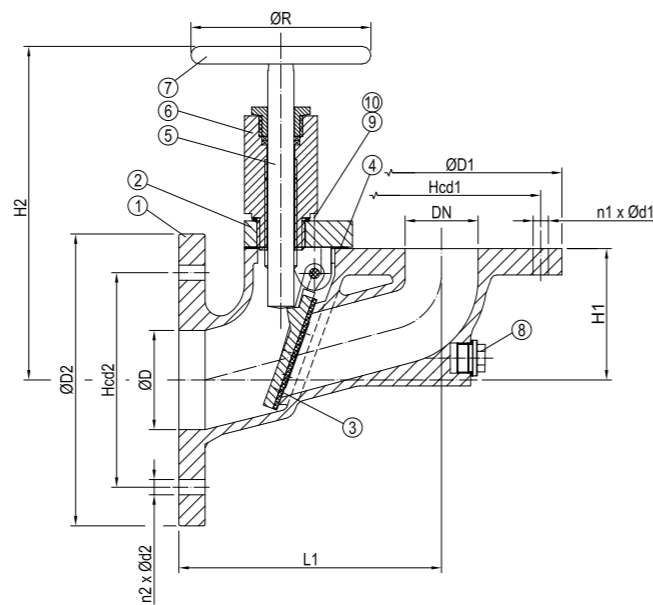
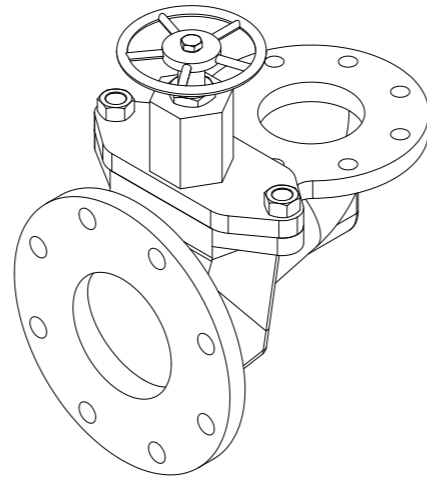

No	Part	Material	Code
1	Body	Cast Steel	GP240GH
2	Bonnet	Cast Steel	GP240GH
3	Disc with Sealing	Bronze +NBR	Rg5 + NBR
4	Bonnet Gasket	NBR	-
5	Stem	Brass	CuZn39Pb3
6	Stem Nut	Brass	CuZn39Pb3
7	Handwheel	Cast Iron	EN-GJL250
8	Plug	Brass	CuZn39Pb3
9	Stud Bolts	Steel	-
10	Nut	Steel	-

DN	n1xØd1	Hcd1	ØD1	n2xØd2	Hcd2	ØD2	ØD	L1	H1	H2	ØR	Kg
50	4x18	125	165	8x18	160	200	70	180	90	260	140	12
65	4x18	145	185	8x18	180	220	85	200	100	270	140	14
80	8x18	160	200	8x18	210	250	100	215	108	290	140	20
100	8x18	180	220	8x22	240	285	130	250	130	305	140	25
125	8x18	210	250	8x22	270	315	158	290	152	330	160	36
150	8x22	240	285	8x22	295	340	190	330	176	260	160	43
200	8x22	295	340	12x22	350	395	240	425	180	350	160	72



STORM FLAP VALVE

ANGLE TYPE, FLANGED ENDS

159321
PN4

DESCRIPTION: Angled type closable check valve. Rg5 body. Soft sealing disc. Flat face PN10 flanged.

APPLICATION: Ship side valve for discharge from various sanitary systems. Preventing sea water from entering the piping system. Manually closable at e.g. dry docking.

STANDARD & DESIGN:

Design Code: -
 Inspection Std.: -
 End Std.: -
 Face to Face Std.: -
 Flanges drilled: PN10(DN40-DN150)
 Pressure rating: PN4(DN40-DN150)

VARIATIONS: Other dimensions and materials on request.

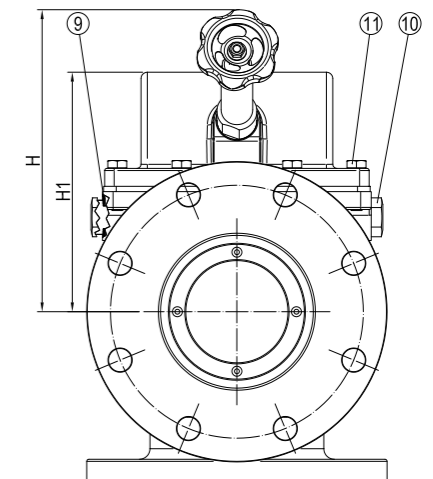
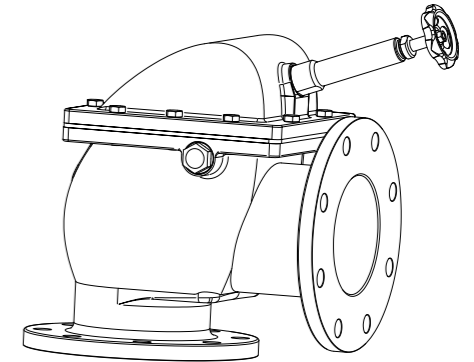

No	Part	Material	Code
1	Body	Bronze	CC 491K
2	Bonnet	Bronze	CC 491K
3	Disc	Bronze	CC 491K
4	Shaft	Brass	CW 602N
5	Bonnet Gasket	NBR	-
6	Disc Gasket	NBR	-
7	Disc Washer	Bronze	CC 491K
8	Rivet	Copper	Cu
9	Washer	Copper	Cu
10	Plug	Brass	CW 602N
11	Bolt	Stainless Steel	EN 1.4404
12	Closing Device	Brass	CW 602N

DN	n x Ød	Hcd	ØD	L1	L2	H	H1	Kg
40	4x18	110	150	90	135	200	110	11.0
50	4x18	125	165	90	145	210	120	13.0
65	4x18	145	185	110	165	270	140	15.9
80	8x18	160	200	115	190	255	145	22.1
100	8x18	180	220	125	215	285	175	30.9
125	8x18	210	250	135	250	340	210	41.2
150	8x22	240	285	160	275	390	260	63.0

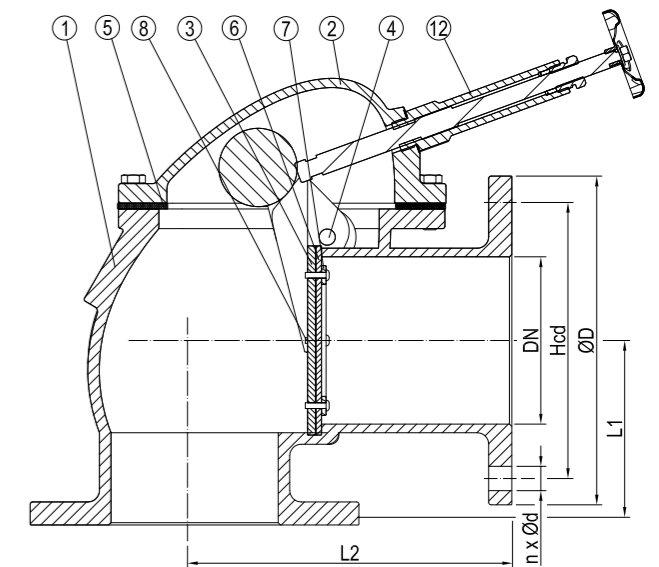



STORM FLAP VALVE

STRAIGHT TYPE, FLANGED ENDS

159701
PN4

DESCRIPTION: Straight type closable check valve. Nodular cast iron body. Soft sealing disc. Flat face PN10 flanged.

APPLICATION: Sanitary piping systems which have a ship's side exit. Ship side valve for discharge from various sanitary systems. Preventing sea water from entering the piping system. Manually closable at e.g. dry docking.

STANDARD & DESIGN:

Design Code: DIN 87101 Form B - with closing device and handwheel.
 Inspection Std.: -
 End Std.: EN 1092/A (DIN 2501)
 Face to Face Std.: EN 558 series 48 (DIN 3202 F6)
 Flanges drilled: PN10 (DN50-DN250)
 Pressure rating: PN 4 (DN50-DN250)
 Temperature range: -10°C to +60°C

VARIATIONS: With open/close indication.
 Other dimensions and materials on request.

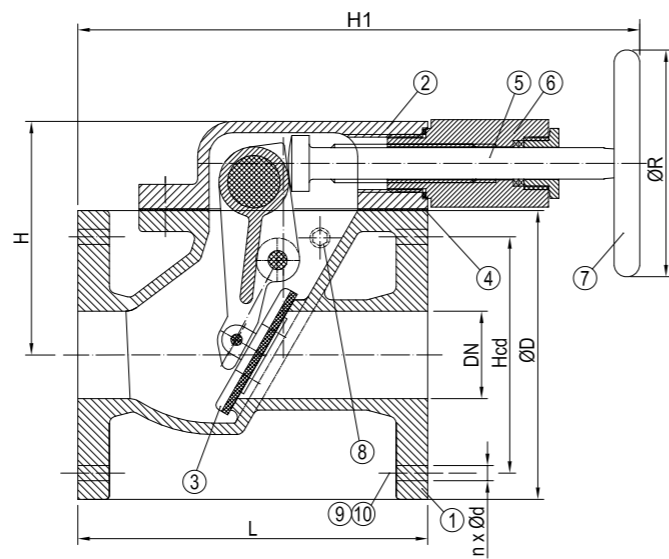
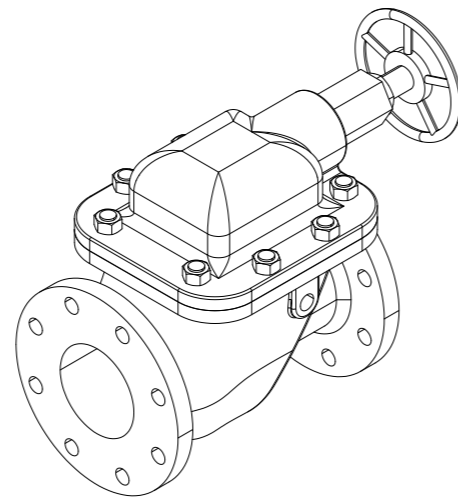

No	Part	Material	Code
1	Body	Nodular Cast Iron	EN-GJS400-18-LT
2	Bonnet	Nodular Cast Iron	EN-GJS400-18-LT
3	Disc with sealing	Bronze +NBR	Rg5 + NBR
4	Bonnet Gasket	NBR	-
5	Stem	Brass	CuZn39Pb3
6	Stem Nut	Brass	CuZn39Pb3
7	Handwheel	Cast Iron	EN-GJL250
8	Plug	Brass	CuZn39Pb3
9	Stud Bolt	Steel	-
10	Nut	Steel	-

DN	n x ød	Hcd	øD	L	H	H1	øR	Kg
50	4x18	125	165	200	140	310	100	14
65	4x18	145	185	240	150	335	100	17
80	8x18	160	200	260	175	390	100	22
100	8x18	180	220	300	200	425	100	28
125	8x18	210	250	350	220	480	125	42
150	8x22	240	285	400	245	525	125	55
200	8x22	295	340	500	315	625	160	101



STORM FLAP VALVE

STRAIGHT TYPE, FLANGED ENDS

159721
PN4

DESCRIPTION: Straight type closable check valve. Rg5 body. Soft sealing disc. Flat face PN10 flanged.

APPLICATION: Ship side valve for discharge from various sanitary systems. Preventing sea water from entering the piping system. Manually closable at e.g. dry docking. Sanitary piping systems which have a ship's side exit.

STANDARD & DESIGN:

Design Code: DIN 87101 Form B - with closing device and handwheel.
 Inspection Std.: -
 End Std.: EN 1092-3/A (DIN 2501)
 Face to Face Std.: EN 558 series 48 (DIN 3202 F6)
 Flanges drilled: PN10 (DN50-DN250)
 Pressure rating: PN 4 (DN50-DN250)
 Temperature range: -10°C to +60°C

VARIATIONS: Other dimensions and materials on request.

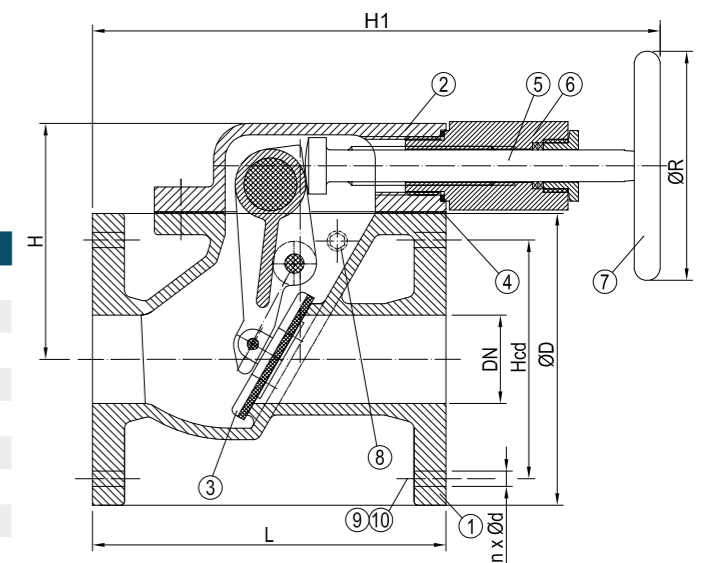
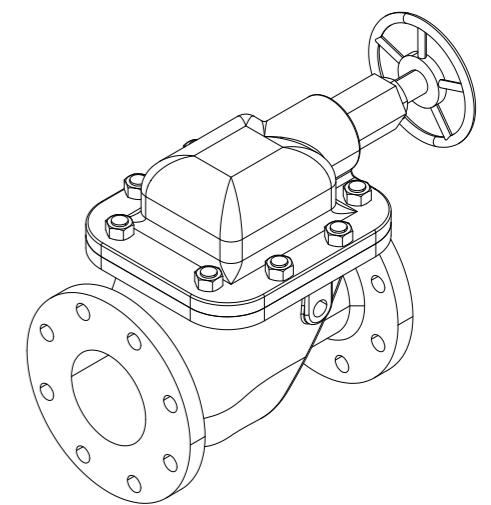

No	Part	Material	Code
1	Body	Bronze	CuSn5ZnPb5-C
2	Bonnet	Bronze	CuSn5ZnPb5-C
3	Disc with sealing	Bronze +NBR	Rg5 + NBR
4	Bonnet Gasket	NBR	-
5	Stem	Brass	CuZn39Pb3
6	Stem Nut	Brass	CuZn39Pb3
7	Handwheel	Cast Iron	EN-GJL250
8	Plug	Stainless Steel	A2 (AISI 304)
9	Stud Bolt	Stainless Steel	A2 (AISI 304)
10	Nut	Stainless Steel	A2 (AISI 304)

DN	n x ød	Hcd	øD	L	H	H1	øR	Kg
50	4x18	125	165	200	140	310	100	16
65	4x18	145	185	240	150	335	100	20
80	8x18	160	200	260	175	390	100	26
100	8x18	180	220	300	200	425	100	33
125	8x18	210	250	350	220	480	125	49
150	8x22	240	285	400	245	525	125	64
200	8x22	295	340	500	315	625	160	118



STORM FLAP VALVE

STRAIGHT TYPE, FLANGED ENDS

159761
PN4

DESCRIPTION: Straight type closable check valve. Cast steel body. Soft sealing disc. Flat face PN10 Flanged.

APPLICATION: Sanitary piping systems which have a ship's side exit. Ship side valve for discharge from various sanitary systems. Preventing sea water from entering the piping system. Manually closable at e.g. dry docking.

STANDARD & DESIGN:

Design Code: DIN 87101 Form B - with closing device and handwheel.
 Inspection Std.: -
 End Std.: EN 1092/A (DIN 2501)
 Face to Face Std.: EN 558 series 48 (DIN 3202 F6)
 Flanges drilled: PN10 (DN50-DN250)
 Pressure rating: PN 4 (DN50-DN250)
 Temperature range: -10°C to +60°C

VARIATIONS: With open/close indication.
 Other dimensions and materials on request.

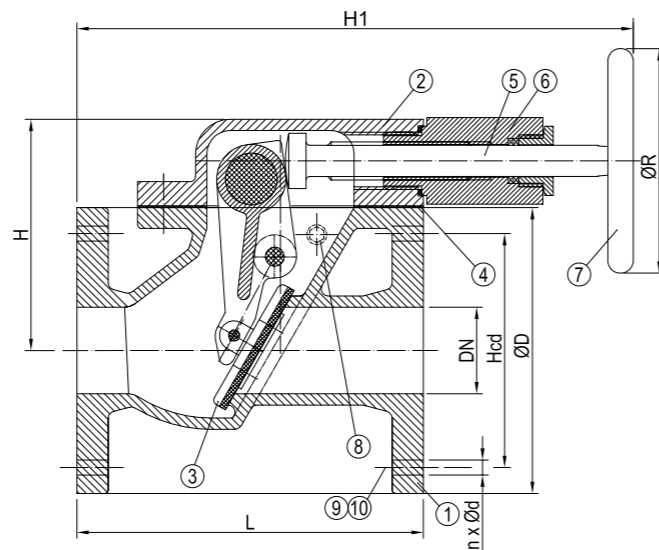
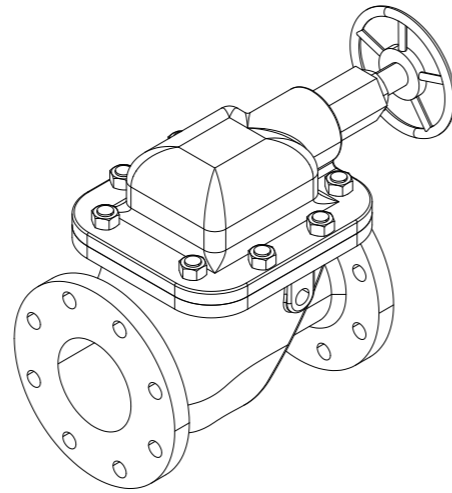

No	Part	Material	Code
1	Body	Cast Steel	GP240GH
2	Bonnet	Cast Steel	GP240GH
3	Disc with sealing	Bronze +NBR	Rg5 + NBR
4	Bonnet Gasket	NBR	-
5	Stem	Brass	CuZn39Pb3
6	Stem Nut	Brass	CuZn39Pb3
7	Handwheel	Cast Iron	EN-GJL250
8	Plug	Brass	CuZn39Pb3
9	Stud Bolt	Steel	-
10	Nut	Steel	-

DN	n x ød	Hcd	øD	L	H	H1	øR	Kg
50	4x18	125	165	200	140	310	100	14
65	4x18	145	185	240	150	335	100	17
80	8x18	160	200	260	175	390	100	22
100	8x18	180	220	300	200	425	100	28
125	8x18	210	250	350	220	480	125	42
150	8x22	240	285	400	245	525	125	55
200	8x22	295	340	500	315	625	160	101



SWING CHECK VALVE

THREADED ENDS

304222
PN16

DESCRIPTION: Straight type, Rg5 body swing check valve with PTFE soft sealing. BSPP female threaded ends.

APPLICATION: Preventing backflow in air, water, sea water and oil systems etc. Suitable for vertical installation.

STANDARD & DESIGN:

Design Code: -
 Inspection Std.: EN12516-3
 End Std.: ISO 228-1:2003
 Face to Face Std.: -
 Pressure rating: PN16(DN10-DN100)
 Temperature range: -10°C to 180°Ct

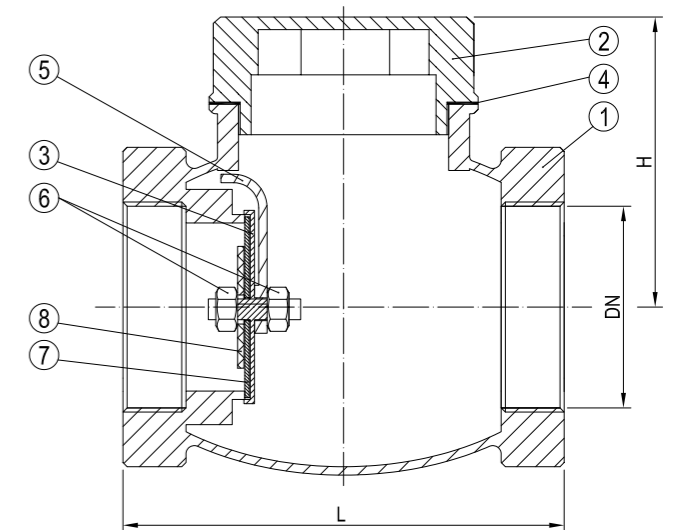
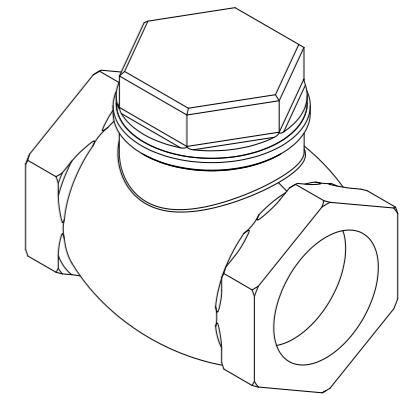

No	Part	Material	Code
1	Body	Bronze	CC491K
2	Bonnet	Brass	CW614-N
3	Disc	Brass	CW614-N
4	Bonnet Gasket	Asbestos free	SIL C4400
5	Swing	Brass	CW614-N
6	Nut	Brass	CW614-N
7	Gasket	PTFE	-
8	Washer	Brass	CW614-N

DN	Inch	L	H	Kg
10	3/8	60	38	0.3
15	1/2	60	38	0.4
20	3/4	70	49	0.5
25	1	80	55	0.8
32	1 1/4	95	59	1.1
40	1 1/2	105	69	1.5
50	2	130	78	2.1
65	2 1/2	160	94	4.6
80	3	184	130	6.9
100	4	215	150	10.0



SWING CHECK VALVE

FLANGED ENDS

304291
200WOG

DESCRIPTION: Straight type, AISI 316 equivalent body swing check valve with PTFE soft sealing. BSPP threaded ends.

APPLICATION: Preventing backflow in air, water, oil and acidic media systems etc.

STANDARD & DESIGN:

Design Code: -
 Inspection Std.: -
 End Std.: ISO 228 CLASS A
 Face to Face Std.: -
 Pressure rating: 200WOG(DN15-DN80)

VARIATIONS: Other dimensions and materials on request.

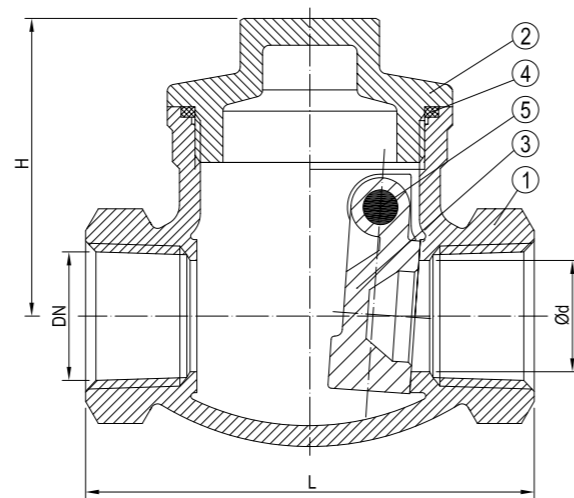
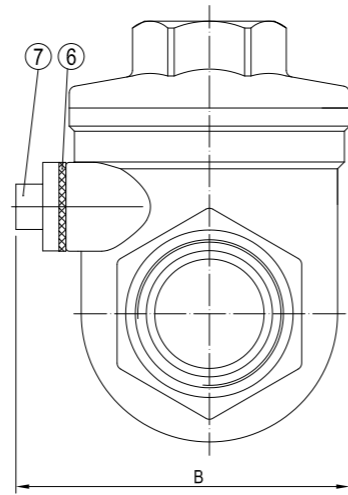
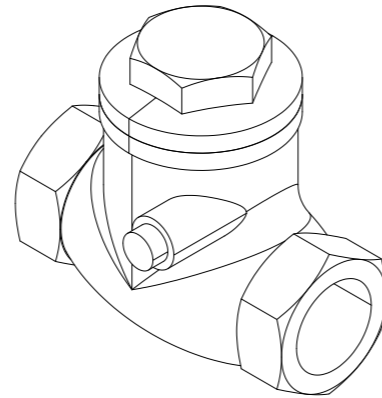
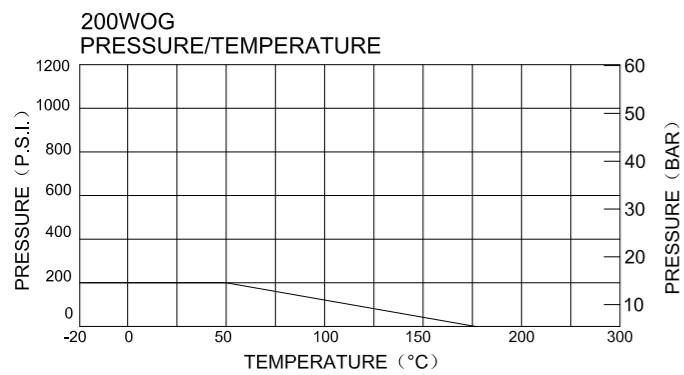

No	Part	Material	Code
1	Body	Stainless Steel	CF8M
2	Bonnet	Stainless Steel	CF8M
3	Disc	Stainless Steel	CF8M
4	Bonnet Gasket	PTFE	-
5	Plug	Stainless Steel	SUS316
6	Gasket	PTFE	-
7	Stopper	Stainless Steel	SUS304

DN	Inch	L	H	ød	B	Kg
15	1/2	65	43	16	46.5	0.3
20	3/4	80	51	20	51.5	0.4
25	1	89	60	25	56.0	0.7
32	1 1/4	105	66	32	64.0	1.0
40	1 1/2	120	75	40	74.5	1.6
50	2	139	80	50	84.0	2.1
65	2 1/2	181	99	65	105	4.6
80	3	200	104	80	140	7.6



SWING CHECK VALVE

FLANGED ENDS

304622
PN16

DESCRIPTION: Straight type, Rg5 body, full bore swing check valve with PTFE soft sealing. Flat face flanged.

APPLICATION: Preventing backflow in water, sea water and oil systems etc.

STANDARD & DESIGN:

Design Code: -
 Inspection Std.: -
 End Std.: UNI EN 1092-3:2005
 Face to Face Std.: -
 Flanges drilled: PN16(DN15-DN100)
 Pressure rating: PN16(DN15-DN100)
 Temperature Range: -10°C to 180°C

VARIATIONS: With metal seat.

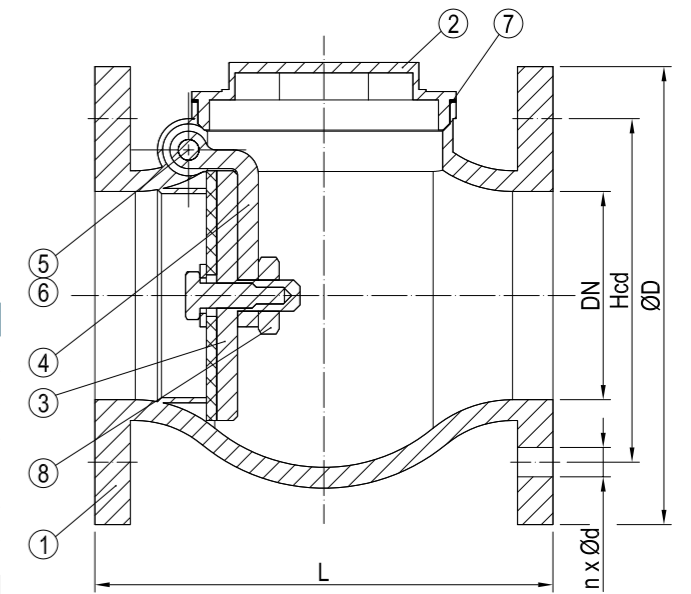
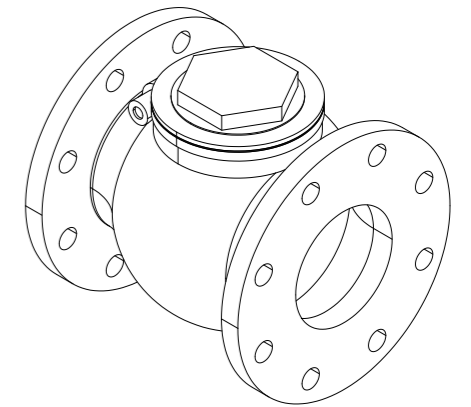

No	Part	Material	Code
1	Body	Bronze	CC491K
2	Plug	Brass	CW614N
3	Disc	Brass	CW614N
4	Swing Arm	Brass	CW614N
5	Pivot	Brass	CW614N
6	Screw	Brass	CW614N
7	Body Gasket	Fiber	-
8	Nut	Brass	CW614N

DN	n x ød	Hd	øD	L	Kg
15	4x14	65	95	90	1.5
20	4x14	75	105	90	1.8
25	4x14	85	115	99	2.5
32	4x18	100	140	110	3.7
40	4x18	110	150	130	4.5
50	4x18	125	165	150	5.7
65	4x18	145	185	175	9.4
80	8x18	160	200	180	10.4
100	8x18	180	220	220	13.0



SWING CHECK VALVE

WAFER TYPE

305072
PN16/PN10

DESCRIPTION: Wafer type Al Bronze swing check valve with NBR soft sealing.

APPLICATION: Preventing backflow in water and sea water systems etc.

STANDARD & DESIGN:

Design Code: -
 Inspection Std.: -
 End Std.: BS4504 PN16 & BS4504 PN10 (DN32-DN500)
 Face to Face Std.: -
 Pressure rating: PN16(DN32-DN150)
 PN10(DN200-DN500)

VARIATIONS: Available with: metal, PTFE, Viton and EPDM seals.
 With spring
 DN200-DN500 as PN16

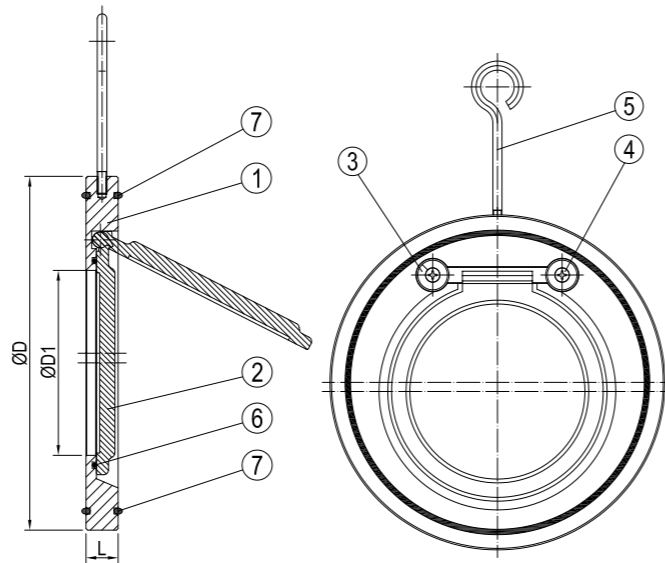
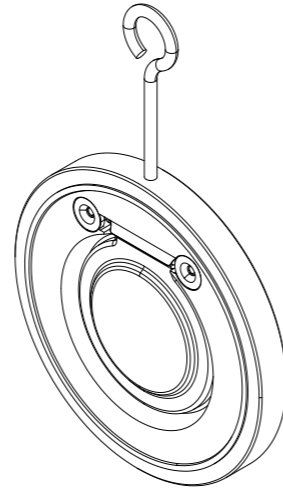

No	Part	Material	Code
1	Body	Al Bronze alloy	-
2	Disc	Al Bronze alloy	-
3	Cover	Stainless Steel	SS 316
4	Screw	Stainless Steel	SS 316
5	Eye Bolt	Stainless Steel	SS 316
6	O-Ring	NBR	-
7	O-Ring	NBR	-

DN	$\varnothing D$	L	$\varnothing D1$	Kg
32	84	14	19	0,8
40	94	14	22	0,9
50	109	14	32	1,0
65	129	14	40	1,2
80	144	14	58	1,5
100	164	18	70	2,5
125	194	18	92	3,3
150	220	20	115	4,7
200	275	22	158	7,8
250	330	26	200	13,0
300	380	32	227	19,0
350	440	38	270	34,0
400	493	44	311	46,0
450	543	50	361	63,0
500	598	56	405	88,0



SWING CHECK VALVE

WAFER TYPE

305092
PN16/PN10

DESCRIPTION: Wafer type AISI 316 body swing check valve with NBR soft sealing.

APPLICATION: Preventing backflow in water, oil systems etc.

STANDARD & DESIGN:

Design Code: -
 Inspection Std.: -
 End Std.: BS4504 PN16 & BS4504 PN10 (DN32-DN500)
 Face to Face Std.: -
 Pressure rating: PN16(DN32-DN150)
 PN10(DN200-DN500)

VARIATIONS: Available with: metal, PTFE, Viton and EPDM seals.
 With spring
 DN200-DN500 as PN16

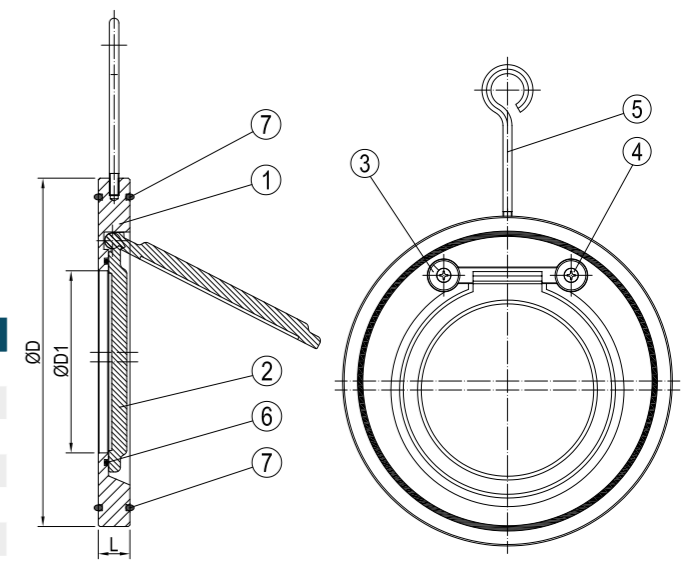
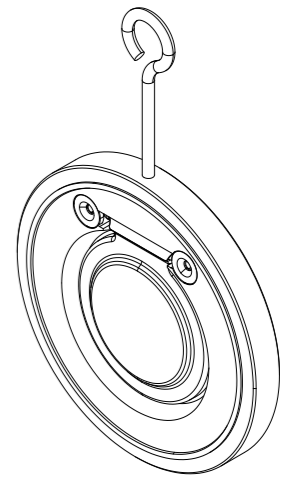

No	Part	Material	Code
1	Body	Stainless Steel	SS 316
2	Disc	Stainless Steel	CF8M
3	Cover	Stainless Steel	SS 316
4	Screw	Stainless Steel	SS 316
5	Eye Bolt	Stainless Steel	SS 316
6	O-Ring	NBR	-
7	O-Ring	NBR	-

DN	$\varnothing D$	L	$\varnothing D1$	Kg
32	84	14	19	0,8
40	94	14	22	0,9
50	109	14	32	1,0
65	129	14	40	1,2
80	144	14	58	1,5
100	164	18	70	2,5
125	194	18	92	3,3
150	220	20	115	4,7
200	275	22	158	7,8
250	330	26	200	13,0
300	380	32	227	19,0
350	440	38	270	34,0
400	493	44	311	46,0
450	543	50	361	63,0
500	598	56	405	88,0



SWING CHECK VALVE

WAFER TYPE

305492
PN16

DESCRIPTION: Wafer type, AISI 316 equivalent, metal seated tilting disc check valve.

APPLICATION: Preventing backflow in water, oil and acidic media systems etc. The tilting disc type reduces the risk of backflow hammering.

STANDARD & DESIGN:

Design Code: -
 Inspection Std.: -
 End Std.: PN16(DN40-DN1200)
 Face to Face Std.: -
 Pressure rating: PN16(DN40-DN1200)

VARIATIONS: With spring and additional counterweight.

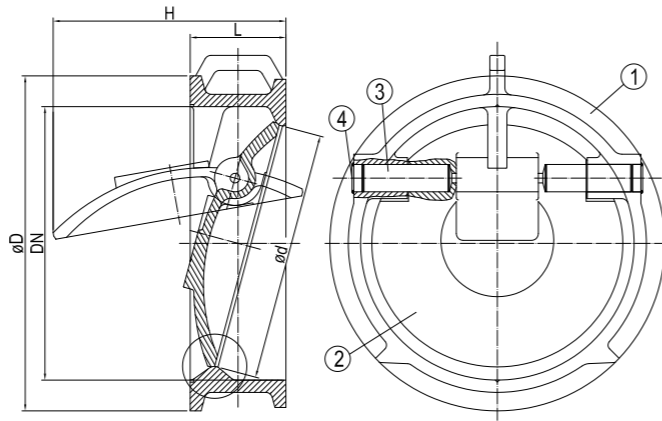
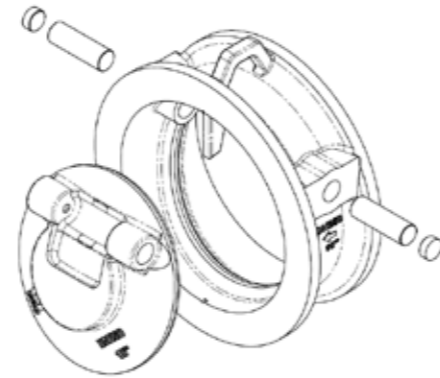

No	Part	Material	Code
1	Body	Stainless Steel	CF8M
2	Disc	Stainless Steel	CF8M
3	Shaft	Stainless Steel	AISI316
4	Plug	Stainless Steel	AISI316

DN	øD	L	H	ød	Kg
40	94	33	45	34	0.6
50	107	43	60	44	1.0
65	127	46	70	58	1.1
80	142	64	90	72	2.0
100	162	64	102	90	3.0
125	194	70	120	112	4.0
150	219	76	140	135	6.0
200	273	89	185	180	10.0
250	329	114	220	225	15.0
300	384	114	262	270	21.0
350	444	127	310	315	30.0
400	496	140	360	365	40.0
450	556	152	400	420	52.0
500	618	152	450	460	62.0
600	735	178	535	555	94.0
700	805	229	620	650	172.0
800	912	241	715	740	236.0
900	1012	275	800	835	303.0
1000	1128	300	920	940	564.0
1200	1342	350	1147	1140	-



SWING CHECK VALVE

SHORT TYPE, FULL BORE, FLANGED ENDS

305802/01
PN16/PN10

DESCRIPTION: Straight type, nodular cast iron body, full bore swing check valve with NBR soft sealing. Short type. Raised face flanged.

APPLICATION: Gaseous and liquid media in oil, gas, water systems, chemical industry. Preventing backflow in water, sea water and oil systems etc.

STANDARD & DESIGN:

Design Code: -
 Inspection Std.: -
 End Std.: EN 1092-2/A (DIN 2501)
 Face to Face Std.: -
 Flanges drilled: PN16 (DN15-DN150)
 PN10(DN200-DN300)
 Pressure rating: PN16 (DN15-DN150)
 PN10(DN200-DN300)

VARIATIONS: EPDM, PTFE, Viton disc seal.

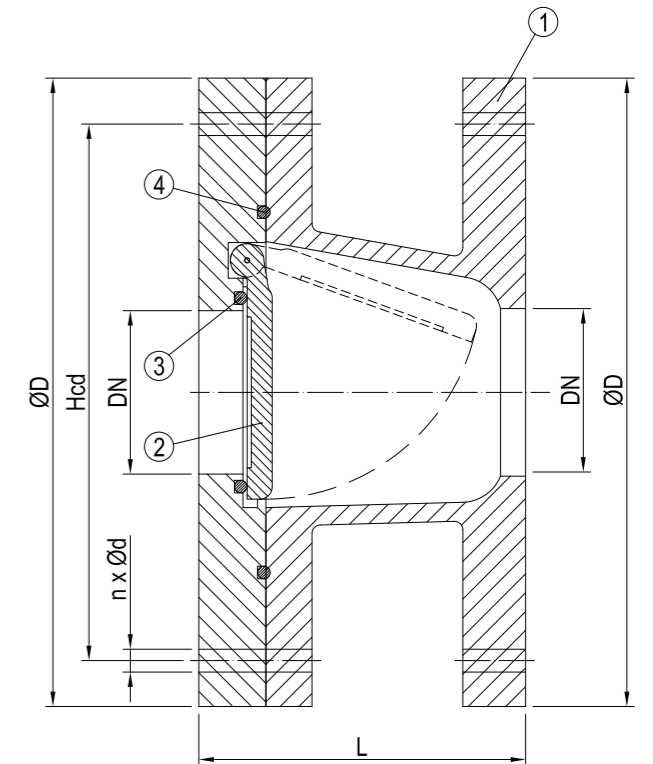
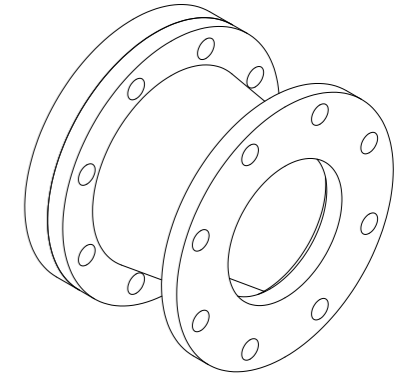

No	Part	Material	Code
1	Body	Nodular Cast Iron	EN-GJS400-18-LT
2	Disc	Bronze	CuSn5Zn5Pb5-C
3	Disc Seal Ring	NBR	-
4	Body Seal Ring	NBR	-

DN	n x ød	Hcd	øD	L	Opening Pressure Horizontal(mmwk)	Kg
15	4x14	65	95	65	230	2
20	4x14	75	105	65	233	2
25	4x14	85	115	70	233	3
32	4x18	100	140	75	237	4
40	4x18	110	150	80	243	5
50	4x18	125	165	85	250	6
65	4x18	145	185	105	110	8
80	8x18	160	200	125	126	10
100	8x18	180	220	145	126	14
125	8x18	210	250	170	128	20
150	8x22	240	285	200	158	26
200	8x22	295	340	255	160	42
250	12x22	350	395	310	215	62
300	12x22	400	445	360	230	78



DUAL PLATE CHECK VALVE

WAFER TYPE

315102/01
PN16/PN10

DESCRIPTION: Wafer type, NBR lined nodular cast iron body, spring tensioned dual check valve with soft sealing AlBr plates.

APPLICATION: Preventing backflow in water, sea water and oil systems etc.

STANDARD & DESIGN:

Design Code: API 594
 Inspection Std.: API 598
 End Std.: DIN 2501 PN10/PN16
 Face to Face Std.: ISO 5752-Series 16
 Pressure rating: PN16(DN50-DN300)
 PN10(DN350-DN700)

VARIATIONS: DN350-DN700 as PN16

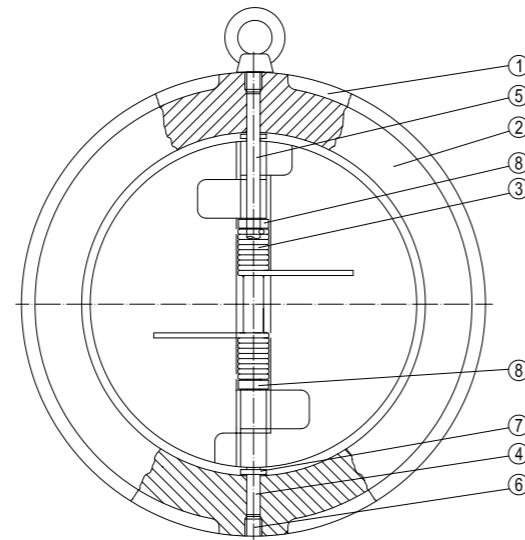
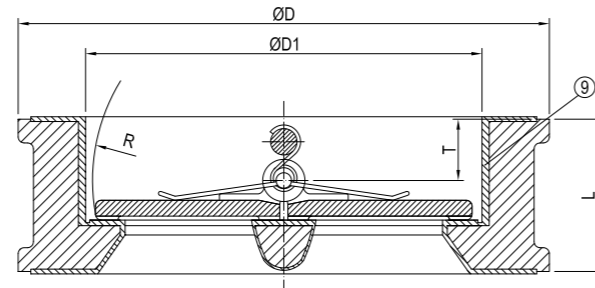
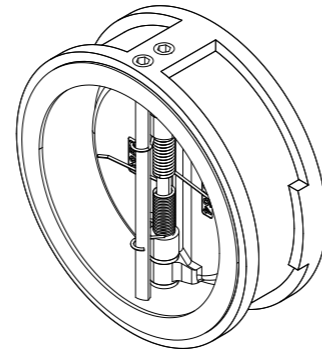

No	Part	Material	Code
1	Body	Nodular Cast Iron	GGG40.3
2	Plate	Al Bronze alloy	ALB-C95400
3	Spring	Inconel	-
4	Hinge Pin	Monel	-
5	Stop Pin	Monel	-
6	Plug	Steel	-
7	Body Bearing	PTFE	-
8	Spring Bearing	PTFE	-
9	Body Seat	NBR	-

DN	Inch	øD	øD1	L	R	T	Kg
50	2	107	65	43	28.8	19	1.5
65	2 1/2	127	80	46	36.1	20	2.0
80	3	142	94	64	43.4	28	3.3
100	4	162	117	64	52.8	27	4.0
125	5	192	145	70	65.7	30	5.5
150	6	218	170	76	78.6	31	8.0
200	8	273	224	89	104.4	33	13.5
250	10	328	265	114	127	50	20.0
300	12	378	310	114	148.3	43	42.0
350	14	438	360	127	173	45	55.0
400	16	489	410	140	198	52	75.0
450	18	539	450	152	217.8	58	100.0
500	20	594	505	152	241	58	120.0
600	24	695	624	178	292	73	-
700	28	810	720	229	350	98	-



DUAL PLATE CHECK VALVE

WAFER TYPE

315192/91
PN16/PN10

DESCRIPTION: Wafer type, AISI 316 body, spring tensioned NBR soft seated dual check valve.

APPLICATION: Preventing backflow in water and oil systems etc.

STANDARD & DESIGN:

Design Code: -
 Inspection Std.: DIN 3230 T3 BO, BN (Leakage Rate 1)
 ISO 5208, Category 3
 API 598 Table 5
 ANSI B 16-104, Class VI
 End Std.: DIN2501 PN10/16, ANSI B16.5, Class 150
 Face to Face Std.: DIN3202-K3/ISO 5752 long
 Pressure rating: PN16(DN50-DN300)
 PN10(DN350-DN800)

VARIATIONS: Available with EPDM and Viton seat.

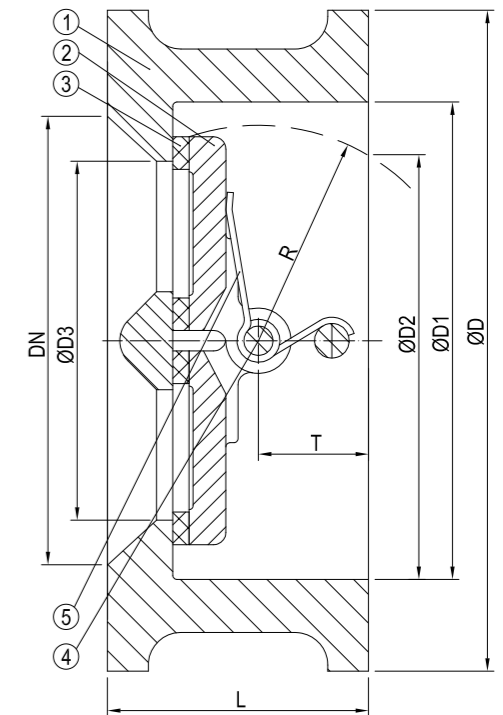
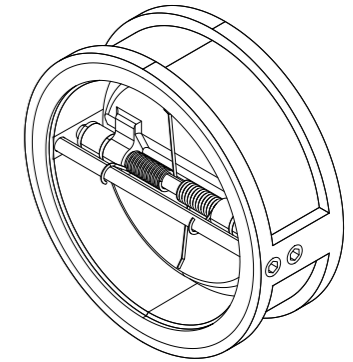

No	Part	Material	Code
1	Body	Stainless Steel	SS316
2	Disc	Stainless Steel	SS316
3	Seat	EPDM/Viton	-
4	Stem	Stainless Steel	SS316
5	Spring	Stainless Steel	SS316

DN	Inch	øD	øD1	øD2	øD3	L	R	T	Kg
50	2	107	65	43.3	40	43	28.8	19	1.5
65	2 1/2	127	80	60.2	60	46	36.1	20	2.4
80	3	142	94	66.4	70	64	43.4	28	3.6
100	4	162	117	90.8	88	64	52.8	27	5.7
125	5	192	145	116.9	115	70	65.7	30	7.3
150	6	218	170	144.6	134	76	78.6	31	9.0
200	8	273	224	198.2	182	89	104.4	33	17.0
250	10	328	265	233.7	220	114	127.0	50	26.0
300	12	378	310	283.9	260	114	148.3	43	42.0
350	14	438	360	332.9	298	127	172.4	45	55.0
400	16	489	410	381.0	350	140	197.4	52	75.0
450	18	539	450	419.9	385	152	217.8	58	101.0
500	20	594	505	467.8	438	152	241.0	58	111.0
600	24	700	624	572.6	538	178	295.4	73	172.0
700	28	820	720	661.6	640	229	345.0	98	-
800	32	930	825	762.2	734	241	394.0	100	-



DUAL PLATE CHECK VALVE

WAFER TYPE

315202/01
PN16/PN10

DESCRIPTION: Wafer type with mounting loops, NBR or EPDM lined nodular cast iron body, spring tensioned dual check valve with soft sealing AlBr plates.

APPLICATION: Food ,beverage industry; Chemical, petrochemical industries; Water and wastewater technology; Shipbuilding; Power plants ; Pulp and paper industries.
Preventing backflow in water, sea water and oil systems etc.

STANDARD & DESIGN:

Design Code: -
 Inspection Std.: DIN 3230 T3 BO, BN (Leakage Rate 1)
 ISO 5208, Category 3
 API 598 Table 5
 ANSI B 16-104, Class VI
 BS4504(PN10/PN16)
 End Std.:
 Face to Face Std.:
 Flanges drilled: PN16(DN50-DN150)
 PN10(DN200-DN600)
 Pressure rating: PN16(DN50-DN150)
 PN10(DN200-DN600)

VARIATIONS: DN200-DN600 available for PN16

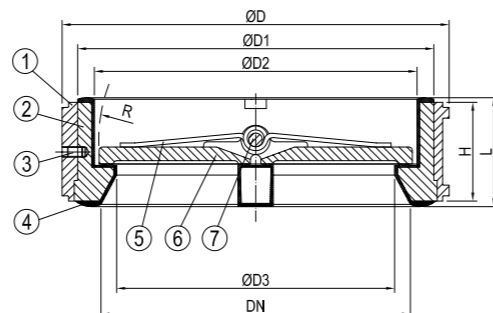
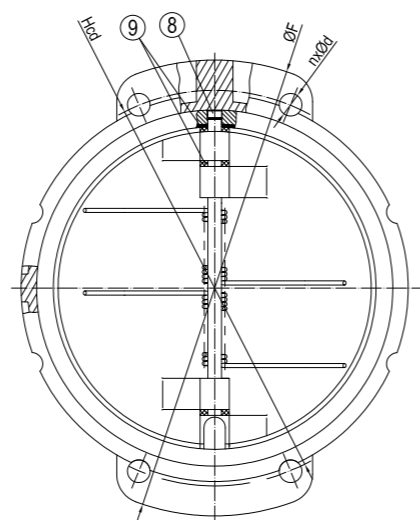
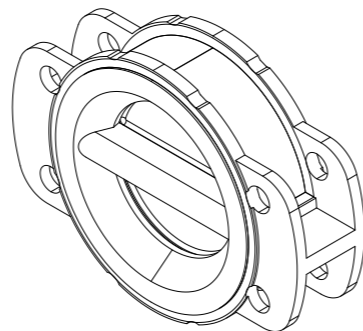

No	Part	Material	Code
1	Alignment Body	Nodular Cast Iron	GGG40.3
2	Insert Body	Nodular Cast Iron	GGG40.3
3	Set Screw	Steel	-
4	Liner	NBR/EPDM	-
5	Spring	Stainless Steel	SS304/SS316
6	Plate	Aluminium Bronze alloy	C954
7	Shaft	Stainless Steel	SS316
8	Shaft Plug	Stainless Steel	SS316
9	Thrust Washer	Teflon	-

DN	Inch	n x ød	Hcd	oF	oD	oD1	oD2	oD3	L	H	R	Kg
50	2	4x19	125	165	101	84.6	66.68	47.6	54	50	29	2.0
65	2 1/2	4x19	145	185	120	98.9	79.38	58.7	54	50	36	2.7
80	3	8x19	160	200	131	116.3	92.08	69.9	54	50	43	3.2
100	4	8x19	180	234	171	143.4	117.48	87.3	63.5	60	53	6.4
125	5	8x19	210	270	193	172	144.46	112.7	66.7	63	66	7.8
150	6	8x23	240	304	222	200.5	171.45	141.3	79.4	76	79	11.1
200	8	8x23	295	367	268	254.3	222.25	192.1	98.4	95	104	19.5
250	10	12x23	350	428	335	308.5	276.23	230.2	101.6	98	127	25.4
300	12	12x23	400	497	403	365.6	327.03	274.6	130.2	126	148	40.4
350	14	16x23	460	570	430	394.8	358.78	306.4	181	178	172	61.8
400	16	16x28	515	635	511	448.8	409.58	355.6	162	159	197	75.0
450	18	20x28	565	640	546	505.9	460.37	406.1	184.2	180.5	218	97.0
500	20	20x28	620	700	597	553.6	511.17	469.9	215.9	212.5	241	126.0
600	24	20x31	725	820	714	655	612.77	565.5	215.9	212.5	295	-



VERTICAL CHECK VALVE

THREADED ENDS

320022
PN16

DESCRIPTION: Straight type, Rg5 body vertical check valve, metal seated. BSPP female threaded ends.

APPLICATION: Preventing backflow in air, water, sea water and oil systems etc. Suitable for vertical installation.

STANDARD & DESIGN:

Design Code: -
 Inspection Std.: EN12516-3
 End Std.: UNI ISO 228-1:2003
 Face to Face Std.: -
 Pressure rating: PN16(DN15-DN65)
 Temperature range: -10°C to 180°C

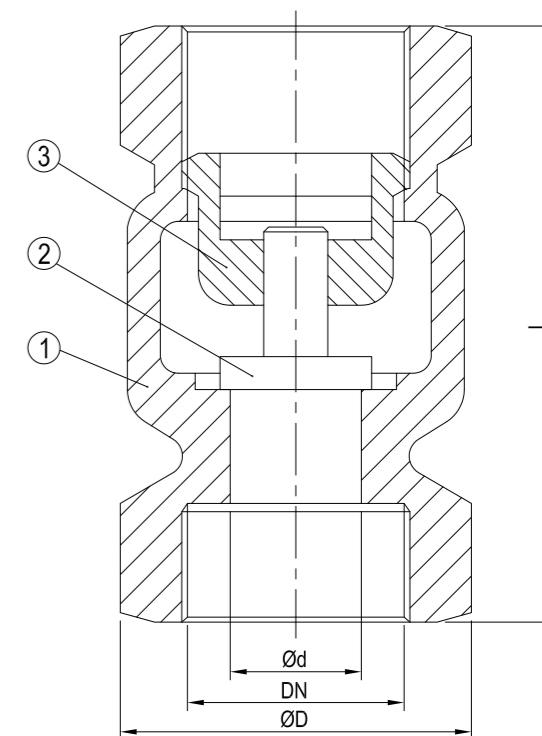
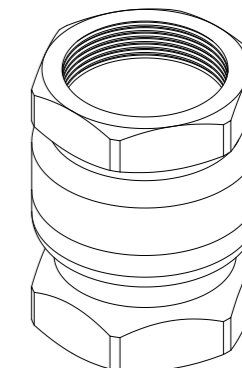

No	Part	Material	Code
1	Body	Bronze	CC491K
2	Disc	Brass	CW614-N
3	Ring Nut	Brass	CW614-N

DN	Inch	øD	L	ød	Kg
10	3/8	34	55	ø10	0.2
15	1/2	34	55	ø12	0.2
20	3/4	42	65	ø18	0.3
25	1	50	70	ø24	0.4
32	1 1/4	62	80	ø32	0.6
40	1 1/2	68	85	ø38	0.9
50	2	83	102	ø50	1.5



SWING CHECK VALVE

FLANGED ENDS

370202/01
PN16/PN10

DESCRIPTION: Straight type, nodular cast iron body, full bore swing check valve with NBR soft sealing. Raised face flanged.

APPLICATION: Cold and hot water, fresh and seawater. Preventing backflow in water, sea water and oil systems etc.

STANDARD & DESIGN:

Design Code: DIN 3232, Rubber sealed.
 Inspection Std.: -
 End Std.: EN 1092-2/B (DIN 2501)
 Face to Face Std.: EN 558 series 48 (DIN 3202 F6)
 Flanges drilled: PN16 (DN32-DN150)
 PN10 (DN200-DN600)
 Pressure rating: PN16 (DN32-DN150)
 PN10 (DN200-DN600)
 Temperature range: -10°C to +120°C

VARIATIONS: With RG5 metal sealing. Lift limiter

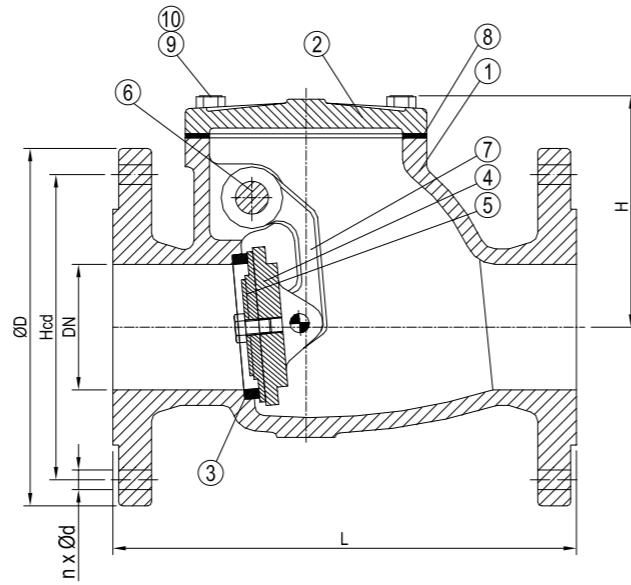
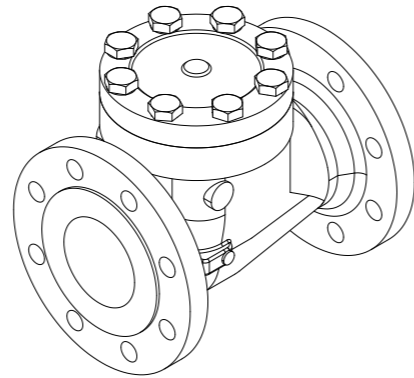

No	Part	Material	Code
1	Body	Nodular Cast Iron	EN-GJS400-18-LT
2	Bonnet	Nodular Cast Iron	EN-GJS400-18-LT
3	Body Seat	Bronze	CuSn5Zn5Pb5-C
4	Disc	Nodular Cast Iron	EN-GJS400-18-LT
5	Disc Sealing	NBR(Standard) Bronze(Optional)	- CuSn5Zn5Pb5-C
6	Stem	Brass	CuZn39Pb3
7	Hinge Arm	Nodular Cast Iron	EN-GJS400-18-LT
8	Bonnet Gasket	Asbestos Free	-
9	Bolt	Steel	-
10	Nut	Steel	-

DN	n x ød	Hcd	øD	L	H	Kg
32	4x18	100	140	180	100	8
40	4x18	110	150	180	100	8
50	4x18	125	165	200	105	10
65	4x18	145	185	240	120	15
80	8x18	160	200	260	145	21
100	8x18	180	220	300	152	26
125	8x18	210	250	350	165	37
150	8x22	240	285	400	190	55
200	8x22	295	340	500	290	112
250	12x22	350	395	600	300	165
300	12x22	400	445	700	365	265
350	16x22	460	505	800	420	365
400	16x26	515	565	900	485	570
500	20x26	620	670	1100	580	950
600	20x30	725	780	1300	700	1180



SWING CHECK VALVE

FLANGED ENDS

370232/31
PN16/PN10

DESCRIPTION: Straight type, Rg10 body, full bore metal seated swing check valve. Flat face flanged.

APPLICATION: Preventing backflow in water, sea water and oil systems etc.

STANDARD & DESIGN:

Design Code: -
 Inspection Std.: -
 End Std.: -
 Face to Face Std.: -
 Flanges Drilled: PN16(DN40-DN150)
 PN10(DN200)
 Pressure rating: PN16(DN40-DN150)
 PN10(DN200)

VARIATIONS: Other dimensions and materials on request.

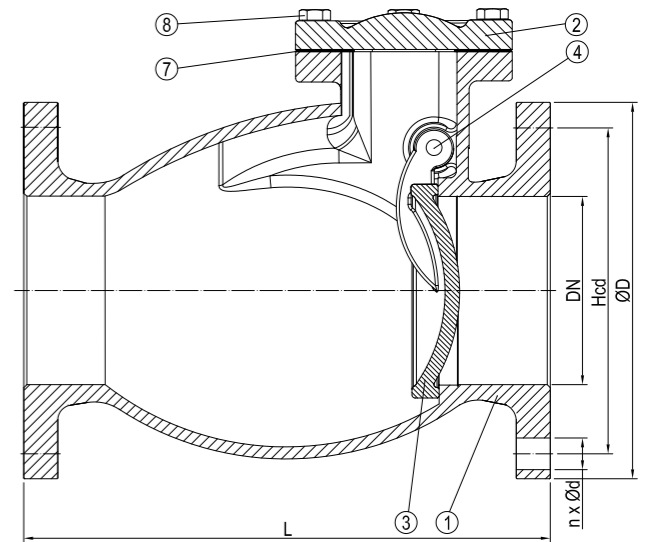
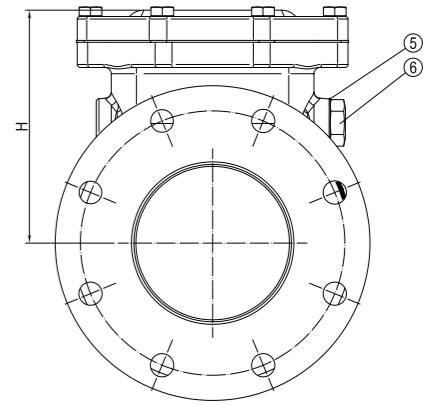
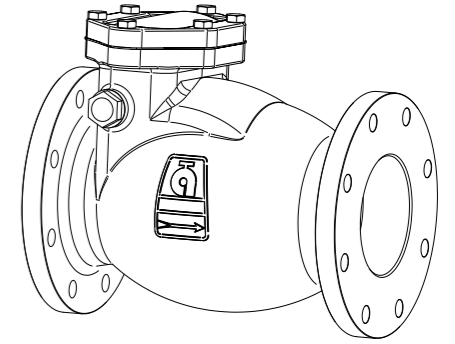

No	Part	Material	Code
1	Body	Bronze	CC 482 K
2	Bonnet	Bronze	CC 482 K
3	Disc	Bronze	CC 482 K
4	Shaft	Al Bronze	CC 333 G
5	Washer	Copper	Cu
6	Plug	Al Bronze	CC 333 G
7	Bonnet Gasket	Dixo 4000	-
8	Bolt	Stainless Steel	EN 1.4404

DN	n x ød	Hcd	øD	L	H	Kg
40	4x18	110	150	180	115	9.7
50	4x18	125	165	200	130	13.8
65	4x18	145	185	240	140	20.3
80	8x18	160	200	260	145	24.2
100	8x18	180	220	300	160	26.9
125	8x18	210	250	350	190	39.0
150	8x22	240	285	400	205	58.0
200	8x22	295	340	500	250	113.0



SWING CHECK VALVE

FLANGED ENDS

370252/51
PN16/PN10

DESCRIPTION: Straight type, grey cast iron body, full bore swing check valve with NBR soft sealing. Raised face flanged.

APPLICATION: Cold and hot water, fresh and seawater. Preventing backflow in water, sea water and oil systems etc.

STANDARD & DESIGN:

Design Code: DIN 3232, Rubber sealed
 Inspection Std.: -
 End Std.: EN 1092-2/B (DIN 2501)
 Face to Face Std.: EN 558 series 48 (DIN 3202 F6)
 Flanges drilled: PN16 (DN32-DN150)
 PN10 (DN200-DN600)
 Pressure rating: PN16 (DN32-DN150)
 PN10 (DN200-DN600)
 Temperature range: -10°C to +120°C

VARIATIONS: With RG5 metal sealing. Lift limiter

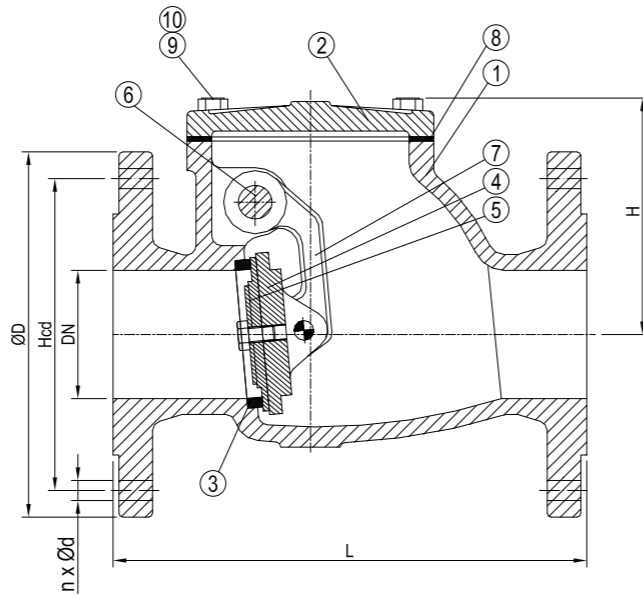
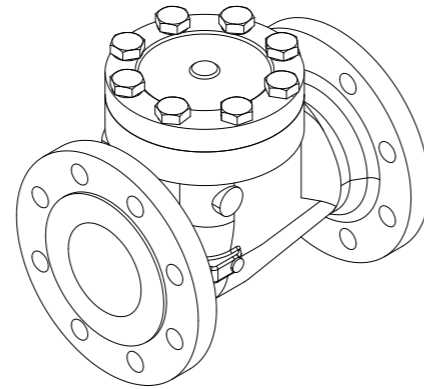

No	Part	Material	Code
1	Body	Cast Iron	EN-GJL250
2	Bonnet	Cast Iron	EN-GJL250
3	Body Seat	Bronze	CuSn5Zn5Pb5-C
4	Disc	Nodular Cast Iron	EN-GJS400-18-LT
5	Disc Sealing	NBR(Standard) Bronze(Optional)	- CuSn5Zn5Pb5-C
6	Stem	Brass	CuZn39Pb3
7	Hinge Arm	Nodular Cast Iron	EN-GJS400-18-LT
8	Bonnet Gasket	Asbestos Free	-
9	Bolt	Steel	-
10	Nut	Steel	-

DN	n x ød	Hcd	øD	L	H	Kg
32	4x18	100	140	180	100	8
40	4x18	110	150	180	100	8
50	4x18	125	165	200	105	10
65	4x18	145	185	240	120	15
80	8x18	160	200	260	145	21
100	8x18	180	220	300	152	26
125	8x18	210	250	350	165	37
150	8x22	240	285	400	190	55
200	8x22	295	340	500	290	112
250	12x22	350	395	600	300	165
300	12x22	400	445	700	365	265
350	16x22	460	505	800	420	365
400	16x26	515	565	900	485	570
500	20x26	620	670	1100	580	950
600	20x30	725	780	1300	700	1180



SWING CHECK VALVE

FLANGED ENDS

370262
PN16

DESCRIPTION: Straight type, cast steel body, full bore Stellite trim swing check valve. Raised face flanged.

APPLICATION: Preventing backflow in water, oil and aggressive/abrasive media etc.

STANDARD & DESIGN:

Design Code: BS 1868
 Inspection Std.: EN 12266-1
 End Std.: EN 1092-1
 Face to Face Std.: EN 558-1
 Flanges drilled: PN16(DN40-DN400)
 Pressure rating: PN16(DN40-DN400)

VARIATIONS: Other dimensions and materials on request.

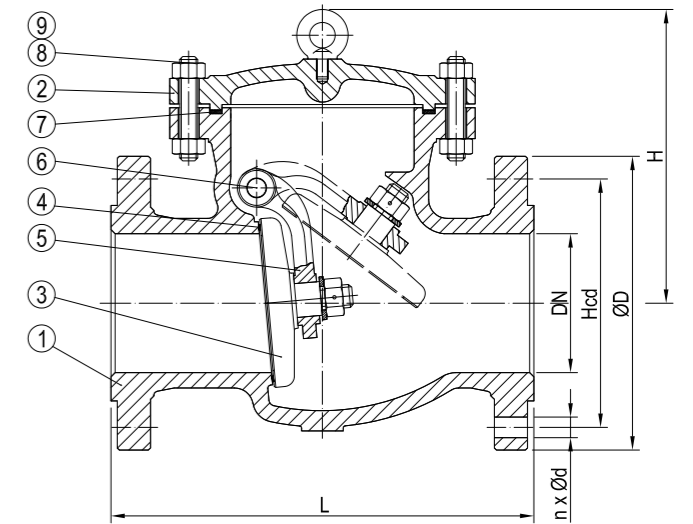
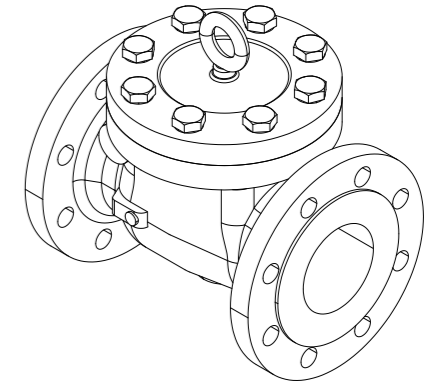

No	Part	Material	Code
1	Body	Cast Steel	ASTM A216-WCB
2	Bonnet	Cast Steel	ASTM A216-WCB
3	Disc	Cast Steel	ASTM A216-WCB
4	Seat	Deposited Stellite	-
5	Hinge	Cast Steel	ASTM A216-WCB
6	Hinge Pin	Stainless Steel	ASTM A276-420
7	Gasket	Graphite	-
8	Stud Bolt	Steel	ASTM A193 Gr.B7
9	Nut	Steel	ASTM A194 Gr.2H

DN	n x ød	Hcd	øD	L	H	Kg
40	4x18	110	150	180	130	18
50	4x18	125	165	200	135	21
65	4x18	145	185	240	142	28
80	8x18	160	200	260	165	38
100	8x18	180	220	300	180	58
125	8x18	210	250	350	210	92
150	8x22	240	285	400	233	130
200	12x22	295	340	500	304	210
250	12x26	355	405	600	348	294
300	12x26	410	460	700	390	367
400	16x30	525	580	900	468	461



LIFT CHECK VALVE

THREADED ENDS

470022
PN16

DESCRIPTION: Straight type, Rg5 body, PTFE soft sealing lift check valve. BSPP female thread.

APPLICATION: Preventing backflow in air, steam, water, sea water and oil systems etc. Suitable when rapid flow reversal can occur, to prevent hammering.

STANDARD & DESIGN:

Design Code: -
 Inspection Std.: EN12516-3
 End Std.: UNI ISO 228-1:2003
 Face to Face Std.: -
 Pressure rating: PN16(DN10-DN50)
 Temperature Range: -10°C to 180°C

VARIATIONS: With metal seat.

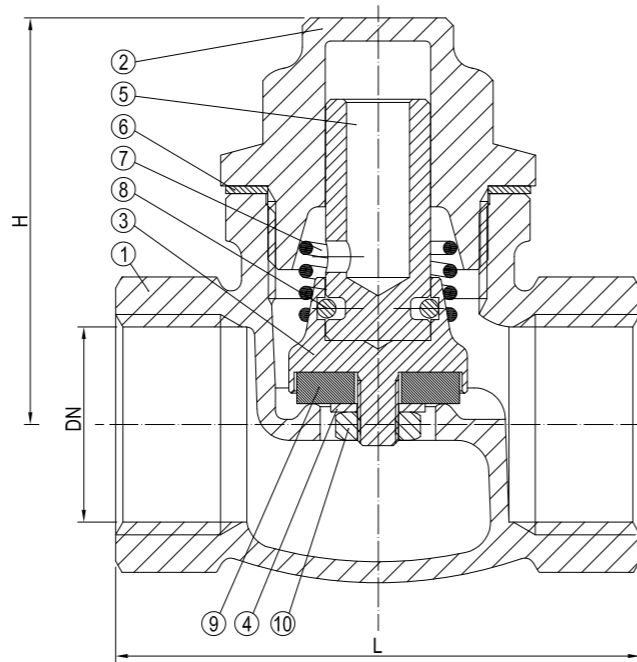
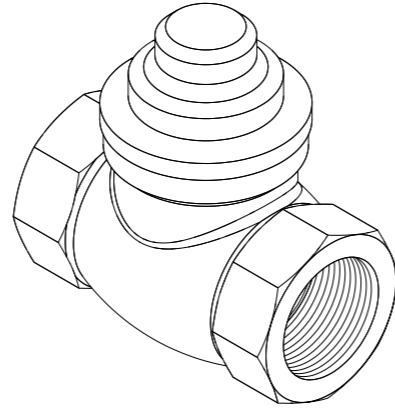

No	Part	Material	Code
1	Body	Bronze	CC931 K
2	Bonnet	Brass	CW614-N
3	Disc	Brass	CW614-N
4	Washer	PTFE	-
5	Stem	Brass	CW614-N
6	Bonnet Gasket	Asbestos Free	SIL C4400
7	Spring	Stainless Steel	-
8	Fixing Ring	Steel	-
9	Gasket	PTFE	-
10	Stem Nut	Brass	CW614-N

DN	Inch	L	H	Kg
8	1/4	65.8	37.4	0.3
10	3/8	65.8	37.4	0.3
15	1/2	65.8	37.4	0.2
20	3/4	75.7	44.6	0.4
25	1	89.7	56.9	0.7
32	1 1/4	109.8	64.2	1.2
40	1 1/2	121	76	1.5
50	2	151.6	87	2.8



PISTON CHECK VALVE

Y-TYPE, THREADED ENDS

471494
PN40

DESCRIPTION: Y-type, AISI 316 equivalent body, PTFE soft sealing spring loaded lift check valve. BSPP female thread.

APPLICATION: Preventing backflow in air, steam, water and oil systems etc. Suitable when rapid flow reversal can occur, to prevent hammering.

STANDARD & DESIGN:

Design Code: -
 Inspection Std.: -
 End Std.: ISO 228
 Face to Face Std.: DIN 3203, Part 4, M8 series (PN40)
 Pressure rating: PN40 (DN8-DN50)
 Temperature Range: 0°C to 180°C

VARIATIONS: Other dimensions and materials on request.

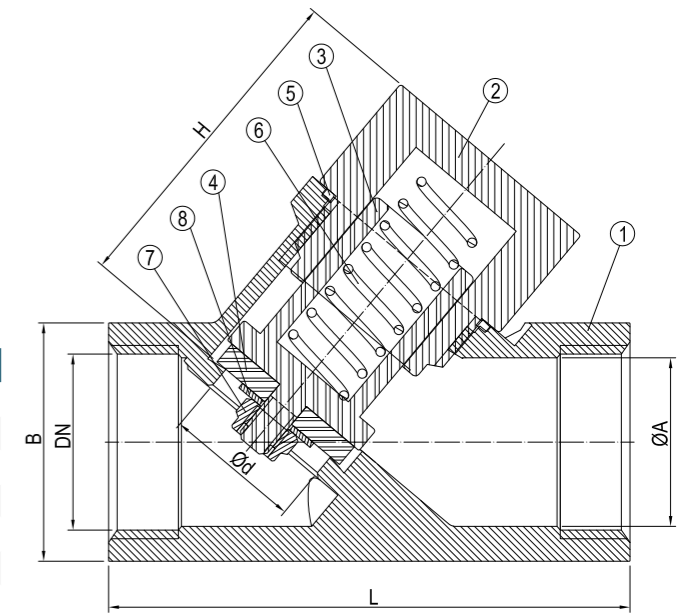
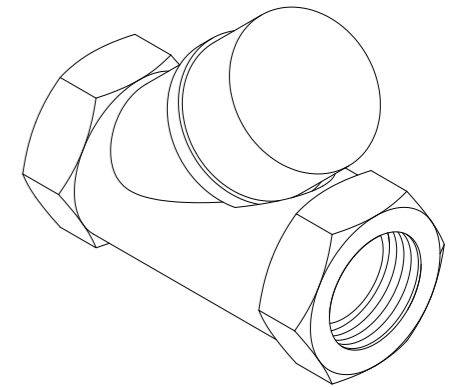
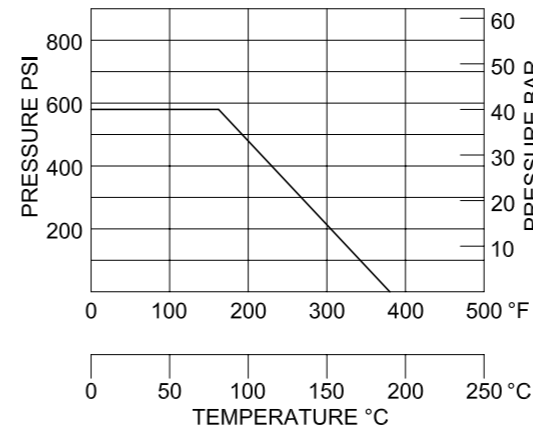

No	Part	Material	Code
1	Body	Stainless Steel	ASTM-A351-CF8M
2	Bonnet	Stainless Steel	ASTM-A351-CF8M
3	Disc	Stainless Steel	AISI 316
4	Seat	PTFE	-
5	Bonnet Gasket	PTFE	-
6	Spring	Stainless Steel	AISI 316
7	Nut	Stainless Steel	AISI 304
8	Washer	Stainless Steel	AISI 304

DN	Inch	L	H	øA	ød	B	Kg
8	1/4	65.8	37.4	11	11.6	27	0.3
10	3/8	65.8	37.4	14	12.5	27	0.3
15	1/2	65.8	37.4	17.5	12.5	27	0.2
20	3/4	75.7	44.6	23	18	32.3	0.4
25	1	89.7	56.9	29	23.5	41	0.7
32	1 1/4	109.8	64.2	38	31.4	50	1.2
40	1 1/2	121	76	44	35.7	55.5	1.5
50	2	151.6	87	56	45.5	70	2.8



LIFT CHECK VALVE

STRAIGHT, FLANGED ENDS

472002/01
PN16/PN10

DESCRIPTION: Straight type, nodular cast iron body, metal seated spring loaded lift check valve. Raised face flanged.

APPLICATION: Cold and hot water, gases, steam and other neutral liquids. Preventing backflow in air, steam, water and oil systems etc. Suitable when rapid flow reversal can occur, to prevent hammering.

VARIATIONS: Without spring. Other dimensions and materials on request.

STANDARD & DESIGN:

Design Code: Body: DIN 86252 with spring.
 Inspection Std.: -
 End Std.: EN 1092-2/B (DIN 2501)
 Face to Face Std.: EN 558 series 1 (DIN 3202 F1)
 Flanges drilled: PN16 (DN15-DN150)
 PN10 (DN200-DN500)
 Pressure rating: PN16(DN15-DN150)
 PN10(DN200-DN250)
 PN6(DN300-DN350)
 PN4(DN400-DN500)
 Temperature range: -10°C to +180°C

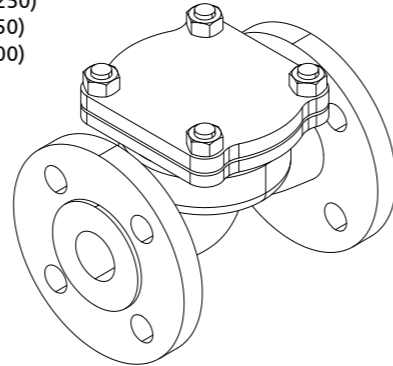

Pressure & Temperature ranges:

Bore	Working Pressure(Bar)	
	Upto 120°C	120°C to +180°C
DN15-DN150	16	10
DN200-DN250	10	6
DN300-DN350	6	4
DN400-DN500	4	2

No	Part	Material	Code
1	Body	Nodular Cast Iron	EN-GJS400-18-LT
2	Bonnet	Nodular Cast Iron	EN-GJS400-18-LT
3	Seat	Bronze	CuSn5Zn5Pb5-C
4	Disc (<=65) (>=80)	Bronze Nodular Cast Iron	CuSn5Zn5Pb5-C EN-GJS400-18-LT
5	Bonnet Gasket	Graphite	-
6	Stud Bolt	Steel	-
7	Nut	Steel	-
8	Spring	Spring Steel	1.4310

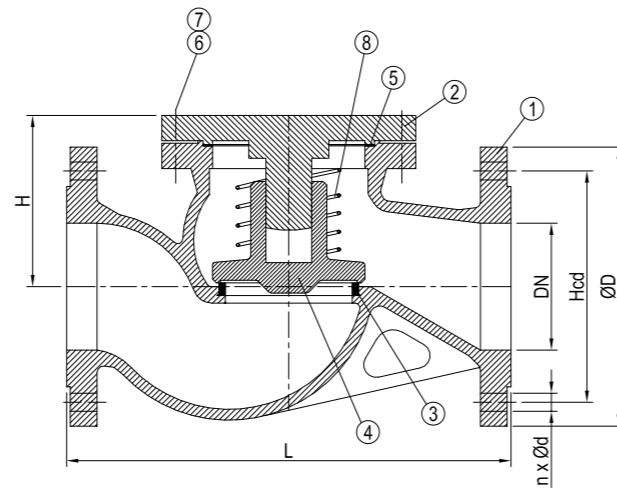

DN	n x ød	Hcd	øD	L	H	Kg
15	4x14	65	95	130	55	3.0
20	4x14	75	105	150	55	3.5
25	4x14	85	115	160	65	4.0
32	4x18	100	140	180	75	5.0
40	4x18	110	150	200	80	8.0
50	4x18	125	165	230	85	10.0
65	4x18	145	185	290	95	14.0
80	8x18	160	200	310	115	22.0
100	8x18	180	220	350	140	38.0
125	8x18	210	250	400	160	47.0
150	8x22	240	285	480	200	60.0
200	8x22	295	340	600	245	115.0
250	12x22	350	395	730	290	150.0
300	12x22	400	445	850	345	230.0
350	16x22	460	505	980	400	280.0
400	16x26	515	565	1100	425	430.0
450	20x26	565	615	1200	450	500.0
500	20x26	620	670	1250	500	670.0



LIFT CHECK VALVE

STRAIGHT TYPE, FLANGED ENDS

472022/21
PN16/PN10

DESCRIPTION: Straight type, Rg5 body, metal seated spring loaded lift check valve. Raised face flanged.

APPLICATION: Sea water, fresh water and waste water. Preventing backflow in sea water, sanitary systems etc. Suitable when rapid flow reversal can occur, to prevent hammering.

VARIATIONS: Without spring. Other dimensions and materials on request.

STANDARD & DESIGN:

Design Code: DIN 86262, Body: DIN 86261
 SDNR - with spring
 Inspection Std.: -
 End Std.: EN 1092-3/B (DIN 2501)
 Face to Face Std.: EN 558 series 1 (DIN 3202 F1)
 Flanges drilled: PN16 (DN15-DN150)
 PN10 (DN200-DN500)
 Pressure rating: PN16(DN15-DN150)
 PN10(DN200-DN250)
 PN6(DN300-DN350)
 PN4(DN400-DN500)
 Temperature range: -10°C to +180°C

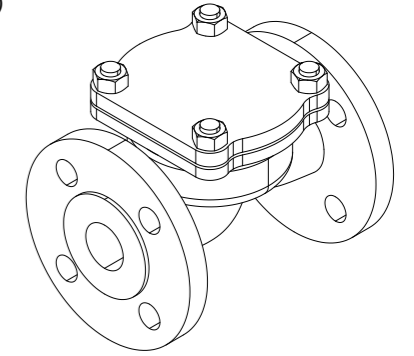

Pressure & Temperature ranges:

Bore	Working Pressure(Bar)	
	Upto 120°C	120°C to 180°C
DN15-DN150	16	10
DN200-DN250	10	6
DN300-DN350	6	4
DN400-DN500	4	2

No	Part	Material	Code
1	Body	Bronze	CuSn5Zn5Pb5-C
2	Bonnet	Bronze	CuSn5Zn5Pb5-C
3	Seat	Bronze	CuSn5Zn5Pb5-C
4	Disc	Bronze	CuSn5Zn5Pb5-C
5	Bonnet Gasket	Graphite	-
6	Stud Bolt	Stainless Steel	A2 (AISI 304)
7	Nut	Stainless Steel	A2 (AISI 304)
8	Spring	Stainless Steel	1.4310

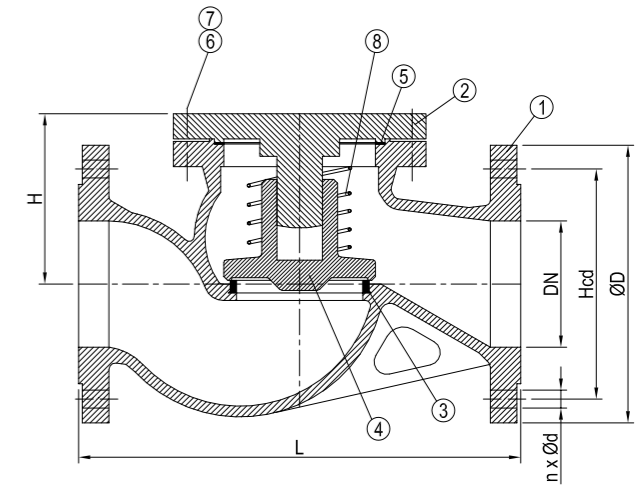

DN	n x ød	Hcd	øD	L	H	Kg
15	4x14	65	95	130	55	3.5
20	4x14	75	105	150	55	4.0
25	4x14	85	115	160	65	4.5
32	4x18	100	140	180	75	5.5
40	4x18	110	150	200	80	9.0
50	4x18	125	165	230	85	11.0
65	4x18	145	185	290	95	15.0
80	8x18	160	200	310	115	24.0
100	8x18	180	220	350	140	32.0
125	8x18	210	250	400	160	48.0
150	8x22	240	285	480	200	65.0
200	8x22	295	340	600	245	150.0
250	12x22	350	395	730	290	190.0
300	12x22	400	445	850	345	240.0
350	16x22	460	505	980	400	290.0
400	16x26	515	565	1100	425	440.0
450	20x26	565	615	1200	450	520.0
500	20x26	620	670	1250	500	690.0



LIFT CHECK VALVE

STRAIGHT TYPE, FLANGED ENDS

472052/51
PN16/PN10

DESCRIPTION: Straight type, grey cast iron body, metal seated spring loaded lift check valve. Raised face flanged.

APPLICATION: Cold and hot water, gases, steam and other neutral liquids. Preventing backflow in air, water, sea water and oil systems etc. Suitable when rapid flow reversal can occur, to prevent hammering.

VARIATIONS: Without spring. Other dimensions and materials on request.

STANDARD & DESIGN:

Design Code: Body: DIN 86252 with spring.
 Inspection Std.: -
 End Std.: EN 1092-2/B (DIN 2501)
 Face to Face Std.: EN 558 series 1 (DIN 3202 F1)
 Flanges drilled: PN16 (DN15-DN150)
 PN10 (DN200-DN500)
 Pressure rating: PN16(DN15-DN150)
 PN10(DN200-DN250)
 PN6(DN300-DN350)
 PN4(DN400-DN500)
 Temperature range: -10°C to +180°C

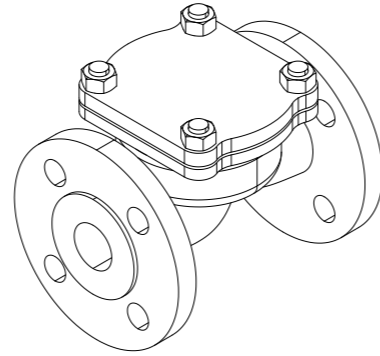

Pressure & Temperature ranges:

Bore	Working Pressure(Bar)	
	Upto 120°C	120°C to 180°C
DN15-DN150	16	10
DN200-DN250	10	6
DN300-DN350	6	4
DN400-DN500	4	2

No	Part	Material	Code
1	Body	Cast Iron	EN-GJL250
2	Bonnet	Cast Iron	EN-GJL250
3	Seat	Bronze	CuSn5Zn5Pb5-C
4	Disc (<=65) (>=80)	Bronze Nodular Cast Iron	CuSn5Zn5Pb5-C EN-GJS400-18-LT
5	Bonnet Gasket	Graphite	-
6	Stud Bolt	Steel	-
7	Nut	Steel	-
8	Spring	Spring Steel	1.4310

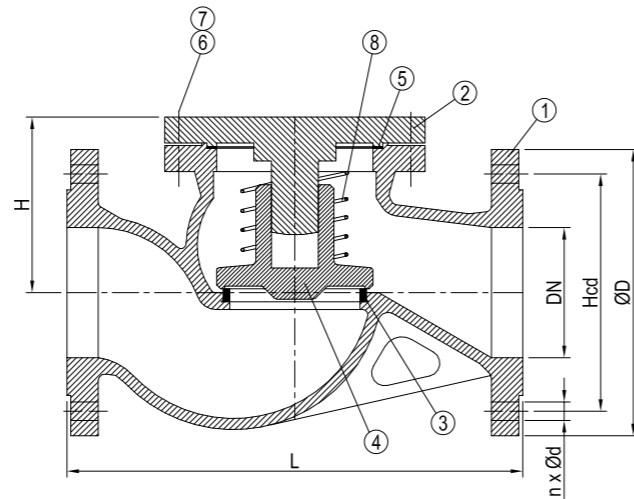

DN	n x ød	Hcd	øD	L	H	Kg
15	4x14	65	95	130	55	3.0
20	4x14	75	105	150	55	3.5
25	4x14	85	115	160	65	4.0
32	4x18	100	140	180	75	5.0
40	4x18	110	150	200	80	8.0
50	4x18	125	165	230	85	10.0
65	4x18	145	185	290	95	14.0
80	8x18	160	200	310	115	22.0
100	8x18	180	220	350	140	38.0
125	8x18	210	250	400	160	47.0
150	8x22	240	285	480	200	60.0
200	8x22	295	340	600	245	115.0
250	12x22	350	395	730	290	150.0
300	12x22	400	445	850	345	230.0
350	16x22	460	505	980	400	280.0
400	16x26	515	565	1100	425	430.0
450	20x26	565	615	1200	450	500.0
500	20x26	620	670	1250	500	670.0



LIFT CHECK VALVE

STRAIGHT TYPE, FLANGED ENDS

472064
PN40

DESCRIPTION: Straight type, cast steel body, metal seated spring loaded lift check valve. Raised face flanges.

APPLICATION: Cold and hot water, gases, steam and other neutral liquids. Preventing backflow in air, steam, water, sea water and oil systems etc. Suitable when rapid flow reversal can occur, to prevent hammering.

STANDARD & DESIGN:

Design Code: Body: EN 13709 with spring
 Inspection Std.: -
 End Std.: EN 1092-1/B (DIN 2501)
 Face to Face Std.: EN 558 series 1 (DIN 3202 F1)
 Flanges drilled: PN40 (DN15-DN150)
 Pressure rating: PN40(DN15-DN150)
 Temperature range: -10°C to +180°C

VARIATIONS: Without spring.
 Other dimensions and materials on request.

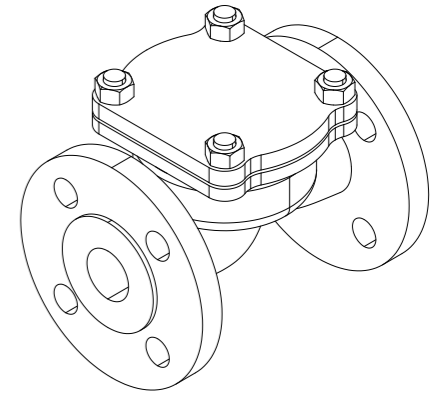

Pressure & Temperature ranges:

Bore	Working Pressure(Bar)	
	Upto 120°C	120°C to 180°C
DN15-DN150	40	33

No	Part	Material	Code
1	Body	Cast Steel	GP240GH
2	Bonnet	Cast Steel	GP240GH
3	Seat	Stainless Steel	AISI 304(1.4301)
4	Disc (<=65) (>=80)	Bronze Cast Steel	CuSn5Zn5Pb5-C GP240GH
5	Bonnet Gasket	Graphite	-
6	Stud Bolt	Steel	-
7	Nut	Steel	-
8	Spring	Spring Steel	1.4310

DN	n x ød	Hcd	øD	L	H	Kg
15	4x14	65	95	130	55	3.5
20	4x14	75	105	150	55	4.0
25	4x14	85	115	160	65	4.5
32	4x18	100	140	180	75	5.5
40	4x18	110	150	200	80	9.0
50	4x18	125	165	230	85	11.0
65	8x18	145	185	290	95	15.0
80	8x18	160	200	310	115	24.0
100	8x22	190	235	350	140	32.0
125	8x26	220	270	400	160	48.0
150	8x26	250	300	480	200	65.0

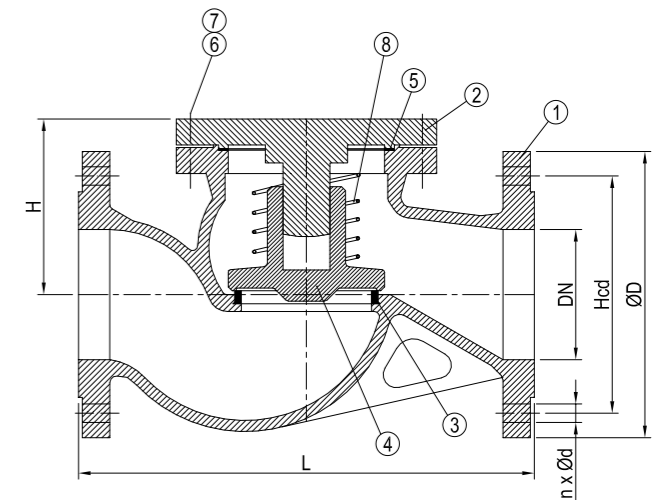



BALL CHECK VALVE

FLANGED ENDS

472401
PN10

DESCRIPTION: Straight type, nodular cast iron body ball check valve. NBR lined ball. Raised face flanged.

APPLICATION: Clean, waste, sewage water and viscous media. Mostly used in water purification stations, sewage treatment installations and pumping stations. Preventing backflow in viscous medias.

STANDARD & DESIGN:

Design Code: -
 Inspection Std.: -
 End Std.: EN 1092-2/B (DIN 2501)
 Face to Face Std.: EN 558 series 48 (DIN 3202 F6)
 Flanges drilled: PN10 (DN40-DN400)
 Pressure rating: PN10 (DN40-DN400)
 Temperature range: -10°C to +120°C

VARIATIONS: Available with EPDM covered ball.

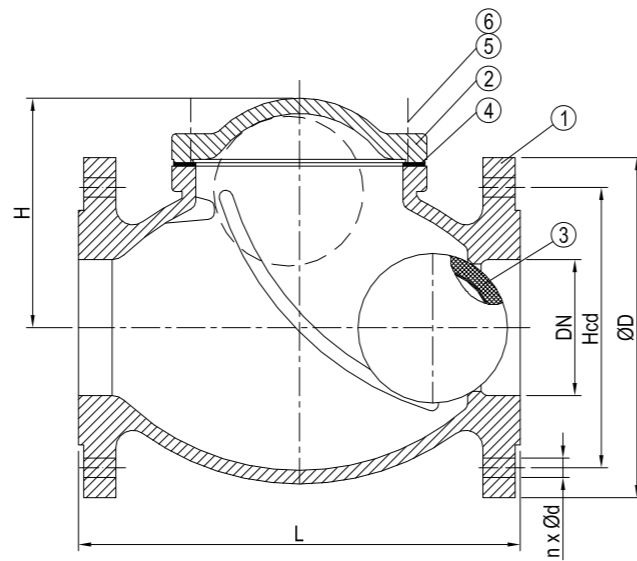
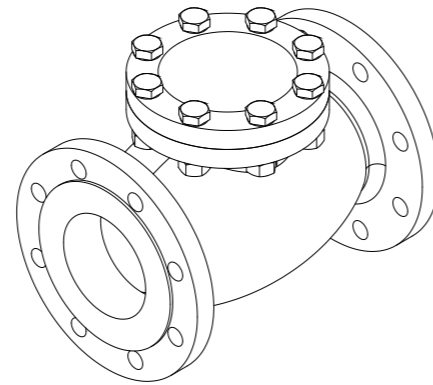

No	Part	Material	Code
1	Body	Nodular Cast Iron	EN-GJS400-15
2	Bonnet	Nodular Cast Iron	EN-GJS400-15
3	Ball	EPDM	-
3	Bonnet Gasket	Asbestos free	-
5	Stud Bolt	Steel	-
6	Nut	Steel	-

DN	n x ød	Hcd	øD	L	H	Kg
40	4x18	110	150	180	92	9
50	4x18	125	165	200	102	10
65	8x18	145	185	240	113	15
80	8x18	160	200	260	135	20
100	8x18	180	220	300	140	25
125	8x18	210	250	350	178	35
150	8x22	240	285	400	203	53
200	8x22	295	340	500	276	90
250	12x22	350	395	600	327	140
300	12x22	400	445	700	390	180
350	16x22	460	505	800	585	270
400	16x26	515	565	900	655	310



BALL CHECK VALVE

FLANGED ENDS

472451
PN10

DESCRIPTION: Straight type, grey cast iron body ball check valve. NBR lined ball. Raised face flanged.

APPLICATION: Clean, waste, sewage water and viscous media. Mostly used in water purification stations, sewage treatment installations and pumping stations. Preventing backflow in viscous medias.

STANDARD & DESIGN:

Design Code: -
 Inspection Std.: -
 End Std.: EN 1092-2/B (DIN 2501)
 Face to Face Std.: EN 558 series 48 (DIN 3202 F6)
 Flanges drilled: PN10 (DN40-DN400)
 Pressure rating: PN10 (DN40-DN400)
 Temperature range: -10°C to +120°C

VARIATIONS: Available with EPDM covered ball.

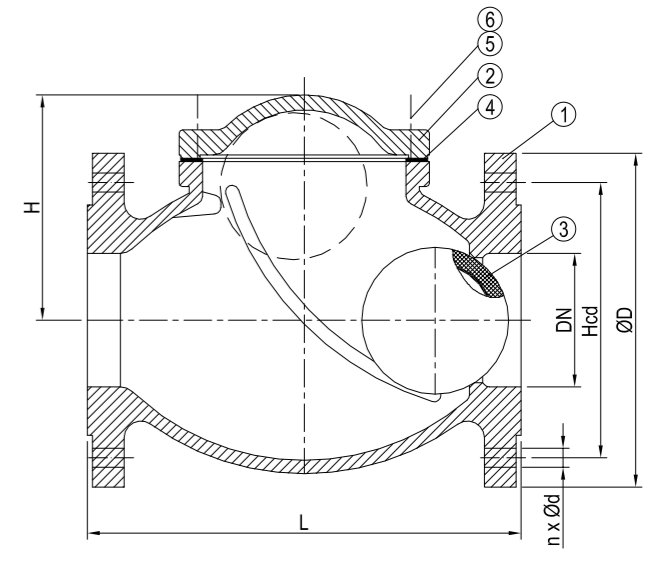
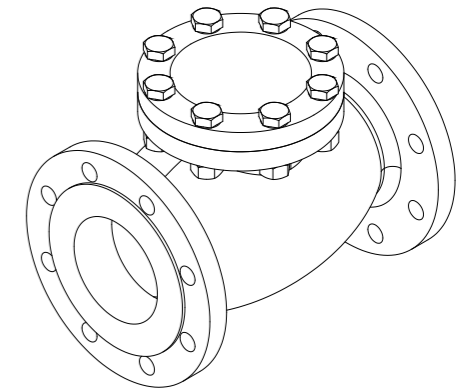

No	Part	Material	Code
1	Body	Cast Iron	EN-GJL250
2	Bonnet	Cast Iron	EN-GJL250
3	Ball	NBR	-
3	Bonnet Gasket	Asbestos free	-
5	Stud Bolt	Steel	-
6	Nut	Steel	-

DN	n x ød	Hcd	øD	L	H	Kg
40	4x18	110	150	180	92	9
50	4x18	125	165	200	102	10
65	8x18	145	185	240	113	15
80	8x18	160	200	260	135	20
100	8x18	180	220	300	140	25
125	8x18	210	250	350	178	35
150	8x22	240	285	400	203	53
200	8x22	295	340	500	276	90
250	12x22	350	395	600	327	140
300	12x22	400	445	700	390	180
350	16x22	460	505	800	585	270
400	16x26	515	565	900	655	310



DISC CHECK VALVE

WAFER TYPE

473072
PN16

DESCRIPTION: Wafer type, Aluminium Bronze body, spring tensioned disc check valve with Viton soft sealing ALBr disc.

APPLICATION: Preventing backflow in water and sea water systems etc. Suitable when rapid flow reversal can occur, to prevent hammering.

STANDARD & DESIGN:

Design Code: -
 Inspection Std.: DIN 3230 T3 BO, BN (Leakage Rate 1)
 ISO 5208, Category 3
 API 598 Table 5
 ANSI B 16-104, Class VI
 End Std.: DIN2501 PN6/10/16
 ANSI B 16.5, Class 150
 Face to Face Std.: DIN3202-K4
 Pressure rating: PN16(DN15-DN200)

VARIATIONS: Other dimensions and materials on request.

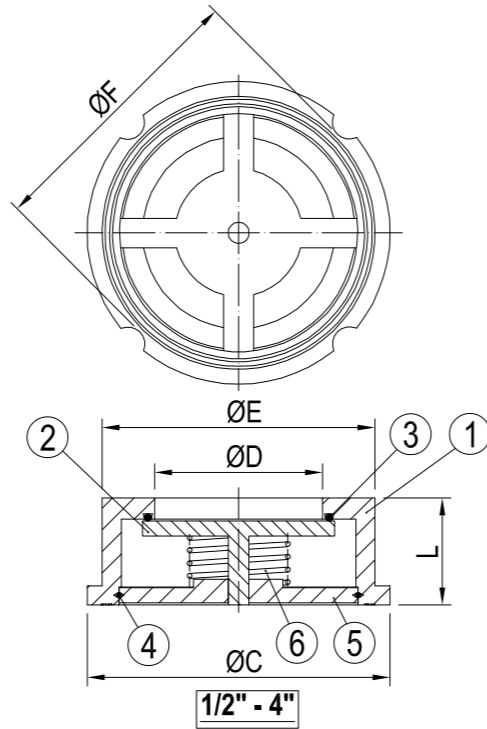
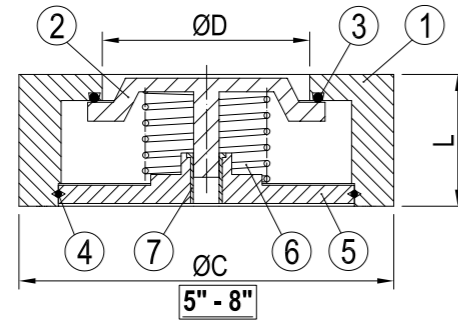
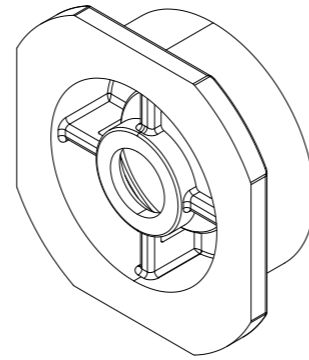

No	Part	Material	Code
1	Body	Aluminium Bronze alloy	C954
2	Disc	Aluminium Bronze alloy	C954
3	O-Ring	VITON	-
4	Spring Circlip	Stainless Steel	316SS
5	Retainer	Stainless Steel	316SS
6	Spring	Stainless Steel	316SS
7	Bushing	Bronze	-

DN	Inch	L	øC	øD	øE	øF
15	1/2	16	51	15	40	44
20	3/4	19	61	20	45	53
25	1	22	71	24	56	63
32	1 1/4	28	82	32	66	75
40	1 1/2	32	92	39	78	85
50	2	40	107	49	90	96
65	2 1/2	46	127	64	110	115
80	3	50	142	78.5	128	131
100	4	60	162	93.5	151	152
125	5	90	194	123	-	-
150	6	106	220	140	-	-
200	8	140	275	183	-	-



DISC CHECK VALVE

WAFER TYPE

473093
PN25

DESCRIPTION: Wafer type, AISI 316 equivalent body, spring tensioned disc check valve with metal sealing.

APPLICATION: Preventing backflow in water, oil, acidic media systems etc. Suitable when rapid flow reversal can occur, to prevent hammering.

STANDARD & DESIGN:

Design Code: -
 Inspection Std.: -
 End Std.: -
 Face to Face Std.: DIN 3202 K4(DN125-DN200)
 DIN 3202 K5(DN250)
 Pressure rating: PN25(DN125-DN250)

VARIATIONS: Other dimensions and materials on request.

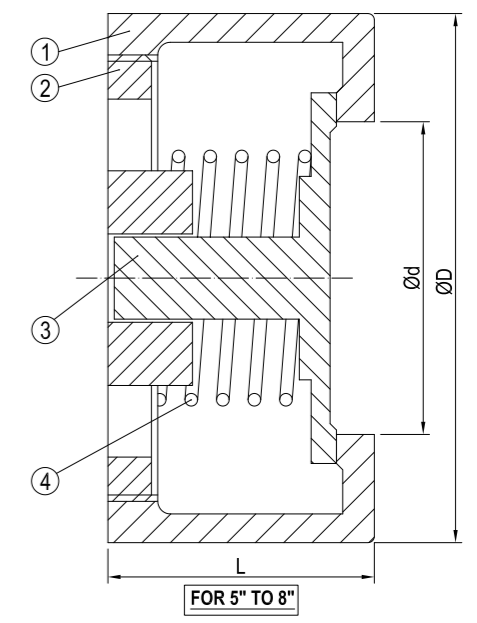
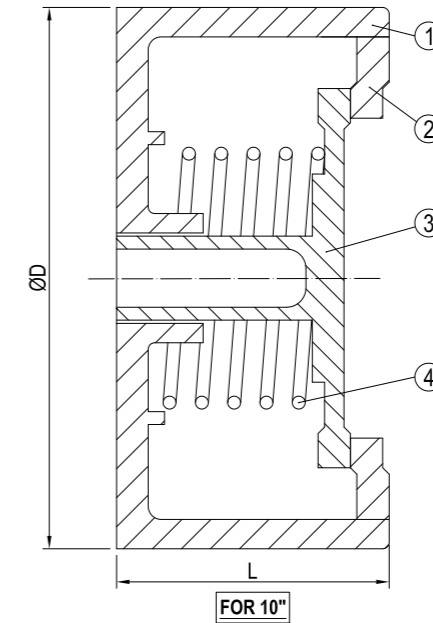
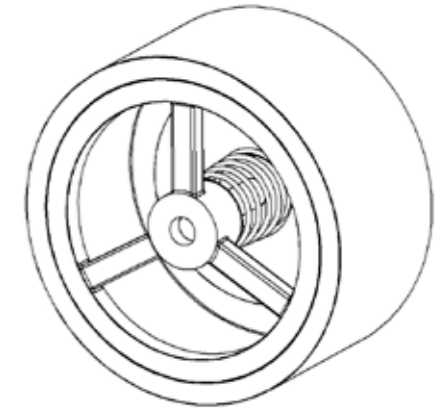

No	Part	Material	Code
1	Body	Stainless Steel	1.4408
2	Cap	Stainless Steel	1.4408
3	Disc	Stainless Steel	1.4408
4	Spring	Stainless Steel	SS316

DN	Inch	øD	L	ød	Kg
125	5	190	90	105	7.4
150	6	218	106	130	10.4
200	8	273	140	170	17.4
250	10	340	220	205	-



DISC CHECK VALVE

WAFER TYPE

473094
PN40

DESCRIPTION: Wafer type, AISI 316 equivalent body, spring tensioned disc check valve with metal sealing.

APPLICATION: Preventing backflow in water, oil, acidic media systems etc. Suitable when rapid flow reversal can occur, to prevent hammering.

STANDARD & DESIGN:

Design Code: -
 Inspection Std.: -
 End Std.: -
 Face to Face Std.: -
 Pressure rating: PN40(DN15-DN100)
 Temperature range: 0°C to 200°C

VARIATIONS: Other dimensions and materials on request.

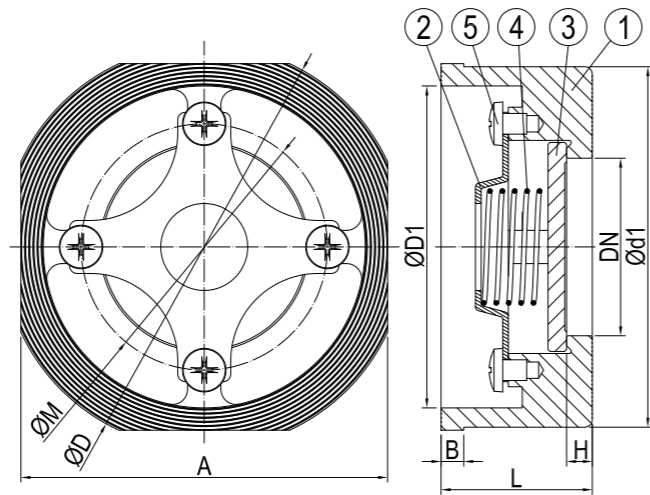
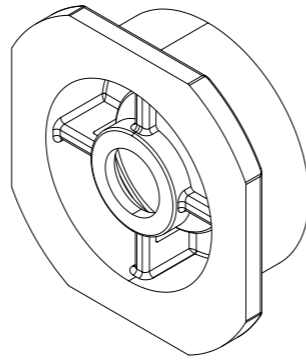

No	Part	Material	Code
1	Body	Stainless Steel	ASTM-A351-CF8M
2	Cap	Stainless Steel	AISI 304
3	Disc	Stainless Steel	ASTM-A351-CF8M
4	Spring	Stainless Steel	AISI 316
5	Screw	Stainless Steel	AISI 304

DN	Inch	øD	A	øM	ød1	øD1	L	H	B	Kg
15	1/2	53	45.6	27.7	43.2	36.9	16.5	4.4	3.4	0.1
20	3/4	63.4	55.3	34.2	52.9	44.6	19.5	4.8	3.5	0.2
25	1	73.5	65.6	39.4	63	54.1	22	5.4	4.3	0.3
32	1 1/4	84.6	79	43.7	75	65.2	28	6	4.5	0.4
40	1 1/2	94	88	54	85.6	76.2	32	6.6	5.3	0.6
50	2	107.1	97.8	63.5	95	85.2	40	7.1	6	0.8
65	2 1/2	126.4	118.3	82.8	114.7	100.8	46	7.8	8.4	1.5
80	3	144.2	134.5	98.8	130.7	119.4	50	8.4	8.8	1.9
100	4	160	153.6	119.8	150.2	130.7	60	9	10.4	3.3



FOOT VALVE

485451
PN10/PN6/PN4

DESCRIPTION: Grey cast iron body, combination of screened suction inlet and soft sealing disc check valve. Raised face flanged.

APPLICATION: Water and natural liquids. Tank bottom suction for a wide range of non aggressive medias.

STANDARD & DESIGN:

Design Code: -
 Inspection Std.: -
 End Std.: EN 1092-2/B (DIN 2501)
 Face to Face Std.: -
 Flanges drilled: PN 10 (DN40-DN500)
 Pressure rating: PN 10 (DN40-DN150)
 PN 6 (DN200-DN300)
 PN 4 (DN350-DN500)
 Temperature range: -10°C to +120°C

VARIATIONS: Other dimensions and materials on request.

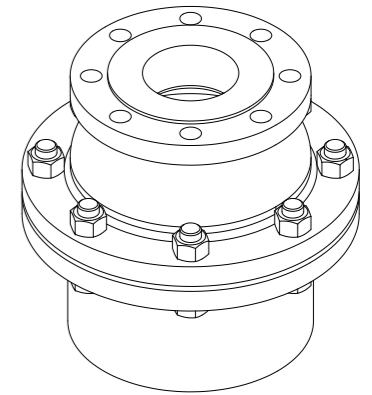

Pressure & Temperature ranges:

Bore	Working Pressure(Bar)	
	90°C	
DN40-DN150	10	
DN200-DN300	6	
DN350-DN500	4	

No	Part	Material	Code
1	Body	Cast Iron	EN-GJS250(GG25)
2	Bonnet	Cast Iron	EN-GJS250(GG25)
3	Disc	Cast Iron	EN-GJS250(GG25)
4	Basket	Stainless steel	AISI 304(1.4301)
5	Disc Ring	EPDM	-
6	Bonnet Gasket	EPDM	-
7	Stud Bolt	Steel	-
8	Nut	Steel	-

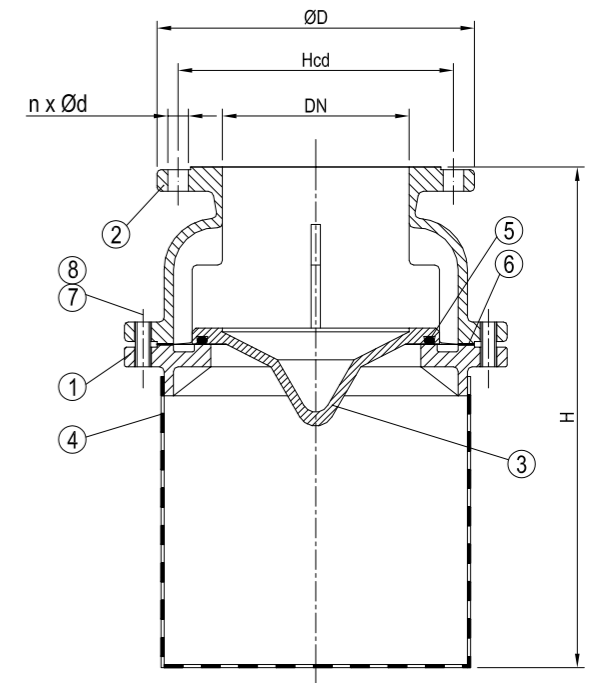

DN	n x ød	Hcd	øD	H	Kg
40	4x18	110	150	230	10
50	4x18	125	165	230	12
65	8x18	145	185	280	14
80	8x18	160	200	300	19
100	8x18	180	220	315	23
125	8x18	210	250	400	35
150	8x22	240	285	505	45
200	8x22	295	340	535	55
250	12x22	350	395	635	100
300	12x22	400	445	710	160
350	16x22	460	505	800	190
400	16x26	515	565	860	210
500	20x26	620	670	945	275



GATE VALVES & KNIFE GATE VALVES

For shut off purposes. Can be delivered with visual position indicator.
Available with threaded, flanged or weld end connections.
Metal to metal sealing or soft sealing.
Available with different types of actuators.



KNIFE-GATE VALVE

BIDIRECTIONAL, WAFER TYPE

396851
PN10

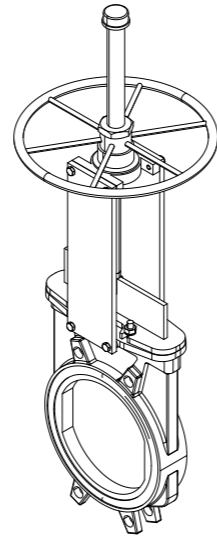

DESCRIPTION: Wafer type, grey cast iron body, NBR soft sealed knife gate valve.

APPLICATION: Chemical plants, Pumping, Food industry, Sewage treatment.
Start/stop flow with minimized pressure drop for water, liquids/slurries containing suspended solids etc.

STANDARD & DESIGN:

Design Code: -
 Inspection Std.: -
 End Std.: EN 1092-2
 Face to Face Std.: -
 Flange drilling: PN10(DN50-DN600)
 Pressure rating: 10 bar(DN50-DN150)
 8 bar(DN200)
 6 bar(DN250-DN300)
 5 bar(DN350-DN400)
 3 bar(DN450-DN600)

VARIATIONS: EPDM, Viton and Silicone seal.

Rising stem
 With actuator

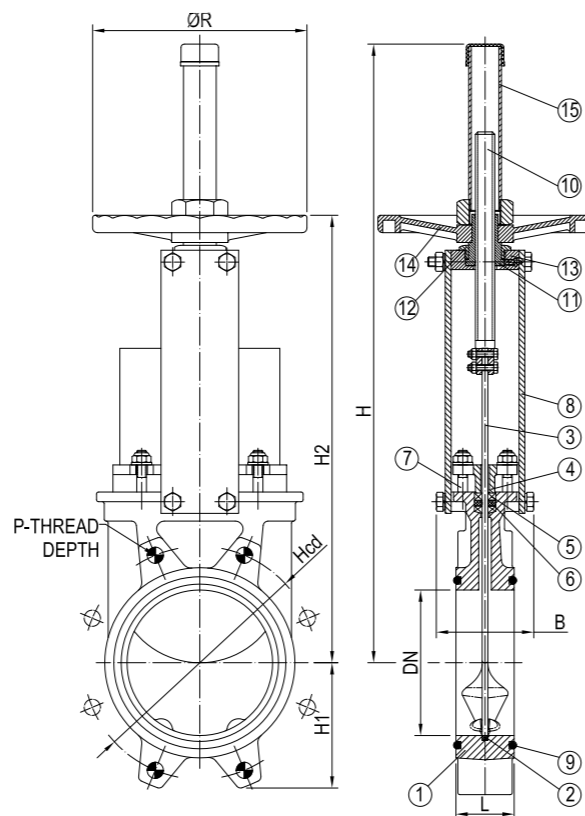

No	Part	Material	Code
1	Body	Cast Iron	GJL250
2	Joint	EPDM	-
3	Knife	Stainless Steel	AISI304
4	Packing Gland	Cast Iron	GJS450
5	Packing	PTFE	-
6	O-Ring	EPDM	-
7	Stud	Steel Zinc	-
8	Support	Steel	-
9	O-Ring	Nitrile	-
10	Spindle	Stainless Steel	AISI303
11	Stem Nut	Bronze	-
12	Nut	Steel	-
13	Yoke	Steel	-
14	Handwheel	Nodular Cast Iron	-
15	Hood	Steel	-

DN	☐	●	P	Hcd	L	H	H1	H2	B	øR	Kg	
50	4	M16	-	8	125	40	409	63	280	92	225	7
65	4	M16	-	8	145	40	436	70	307	92	225	8
80	4	M16	4	10	160	50	469	92	333	92	225	9
100	4	M16	4	10	180	50	502	105	373	92	225	11
125	4	M16	4	10	210	50	585	120	406	102	225	13
150	4	M20	4	10	240	60	644	130	458	102	225	17
200	4	M20	4	10	295	60	815	160	578	119	325	28
250	6	M20	6	12	350	70	1016	198	679	119	325	40
300	6	M20	6	12	400	70	1116	234	779	119	380	56
350	12	M20	4	21	460	96	1336	256	906	290	450	94
400	12	M24	4	21	515	100	1442	292	1012	290	450	116
450	16	M24	4	22	565	106	1628	308	1098	290	450	162
500	16	M24	4	22	620	110	1738	340	1210	290	450	187
600	16	M27	4	22	725	110	2046	400	1416	290	450	260



KNIFE-GATE VALVE

BIDIRECTIONAL, WAFER TYPE

396891
PN10

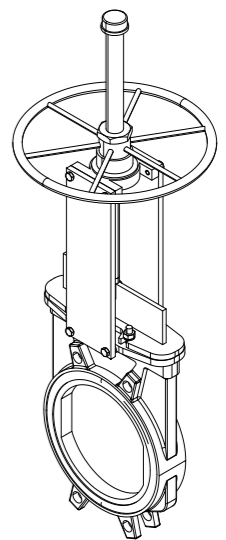

DESCRIPTION: Wafer type, AISI 316 equivalent body, NBR soft sealed knife gate valve.

APPLICATION: Chemical plants, Pumping, Food industry, Sewage treatment.
Start/stop flow with minimized pressure drop for water, liquids/slurries containing suspended solids etc.

STANDARD & DESIGN:

Design Code: -
 Inspection Std.: -
 End Std.: EN 1092-2
 Face to Face Std.: -
 Flange drilling: PN10(DN50-DN600)
 Pressure rating: 10 bar(DN50-DN150)
 8 bar(DN200)
 6 bar(DN250-DN300)
 5 bar(DN350-DN400)
 3 bar(DN450-DN600)

VARIATIONS: EPDM, Viton and Silicone seal.

Rising stem
 With actuator

No	Part	Material	Code
1	Body	Stainless Steel	CF8M
2	Joint	EPDM	-
3	Knife	Stainless Steel	AISI316
4	Packing Gland	Stainless Steel	CF8M
5	Packing	PTFE	-
6	O-Ring	EPDM	-
7	Stud	Stainless Steel	AISI304
8	Support	Steel	-
9	O-Ring	Nitrile	-
10	Spindle	Stainless Steel	AISI303
11	Stem Nut	Bronze	-
12	Nut	Steel	-
13	Yoke	Steel	-
14	Handwheel	Nodular Cast Iron	-
15	Hood	Steel	-

DN	☐	●	P	Hcd	L	H	H1	H2	B	øR	Kg	
50	4	M16	-	8	125	40	409	63	280	92	225	7
65	4	M16	-	8	145	40	436	70	307	92	225	8
80	4	M16	4	10	160	50	469	92	333	92	225	9
100	4	M16	4	10	180	50	502	105	373	92	225	11
125	4	M16	4	10	210	50	585	120	406	102	225	13
150	4	M20	4	10	240	60	644	130	458	102	225	17
200	4	M20	4	10	295	60	815	160	578	119	325	28
250	6	M20	6	12	350	70	1016	198	679	119	325	40
300	6	M20	6	12	400	70	1116	234	779	119	380	56
350	12	M20	4	21	460	96	1336	256	906	290	450	94
400	12	M24	4	21	515	100	1442	292	1012	290	450	116
450	16	M24	4	22	565	106	1628	308	1098	290	450	162
500	16	M24	4	22	620	110	1738	340	1210	290	450	187
600	16	M27	4	22	725	110	2046	400	1416	290	450	260

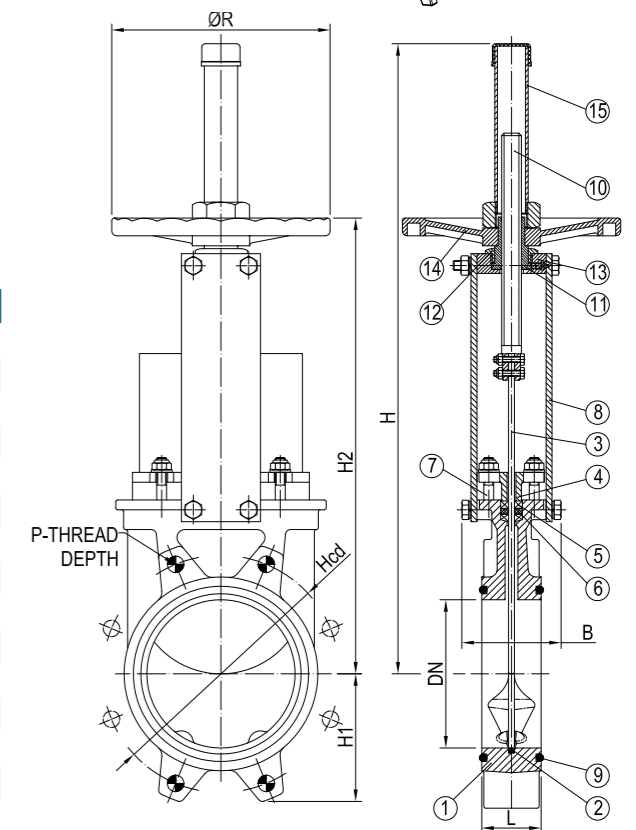



GATE VALVE

FLANGED ENDS

398362
PN16

DESCRIPTION: Cast steel gate valve with stellite coated steel wedge and stellite coated seat. Rising stem, bolted bonnet. Raised face flanged.

APPLICATION: Start/stop flow with minimized pressure drop for water, oils, aggressive/abrasive media etc.

STANDARD & DESIGN:

Design Code: EN 1984
 Inspection Std.: EN 12266-1
 End Std.: EN 1092-1
 Face to Face Std.: EN 558-1
 Flanges drilled: PN16(DN50-DN350)
 Pressure rating: PN16(DN50-DN350)

VARIATIONS: Other dimensions and materials on request.

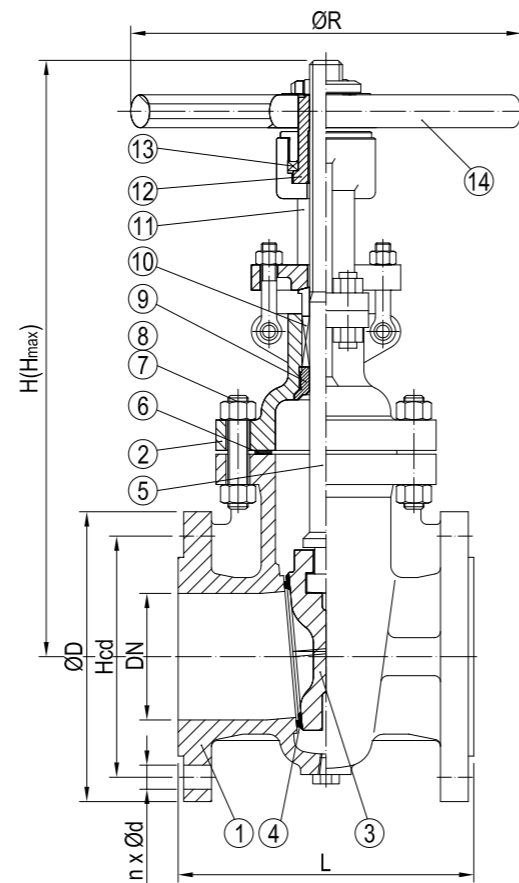
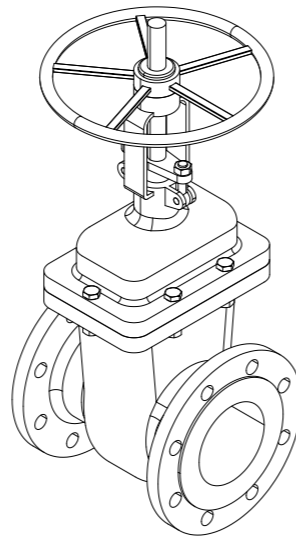

No	Part	Material	Code
1	Body	Cast Steel	ASTM A216-WCB
2	Bonnet	Cast Steel	ASTM A216-WCB
3	Wedge	Cast Steel	ASTM A216-WCB
4	Seat	Deposited Stellite	-
5	Stem	Stainless Steel	ASTM A182-F6a
6	Bonnet Gasket	Graphite	-
7	Stud Bolt	Steel	ASTM A193 Gr.B7
8	Nut	Steel	ASTM A194 Gr.2H
9	Back Seat Bushing	Stainless Steel	ASTM A276-420
10	Packing	Graphite	-
11	Yoke	Cast Steel	ASTM A216-WCB
12	Stem Nut	Al-Bronze alloy	-
13	Axel tree	Steel	E51100
14	Handwheel	Cast Iron	-

DN	n x ød	Hcd	øD	L	H	H _{max}	øR	Kg
50	4x18	125	165	180	358	438	240	29
65	4x18	145	185	200	375	450	240	33
80	8x18	160	200	210	433	528	280	45
100	8x18	180	220	230	502	620	320	63
125	8x18	210	250	255	612	753	380	108
150	8x22	240	285	280	676	847	380	134
200	12x22	295	340	330	820	1039	400	192
250	12x26	355	405	380	969	1245	450	273
300	12x26	410	460	430	1142	1472	580	379
350	16x26	470	520	480	1280	1450	640	590



GATE VALVE

THREADED ENDS

400622
PN16

DESCRIPTION: Rg5 body gate valve, brass wedge. Non rising stem, screwed bonnet. BSPP female thread.

APPLICATION: Start/stop flow with minimized pressure drop for air/gases, water, oils etc.

STANDARD & DESIGN:

Design Code: -
 Inspection Std.: EN 12266-1
 End Std.: UNI ISO 228-1:2003
 Face to Face Std.: -
 Pressure rating: PN16(DN8-DN150)
 Temperature Range: -10°C to 120°C

VARIATIONS: Other dimensions and materials on request.

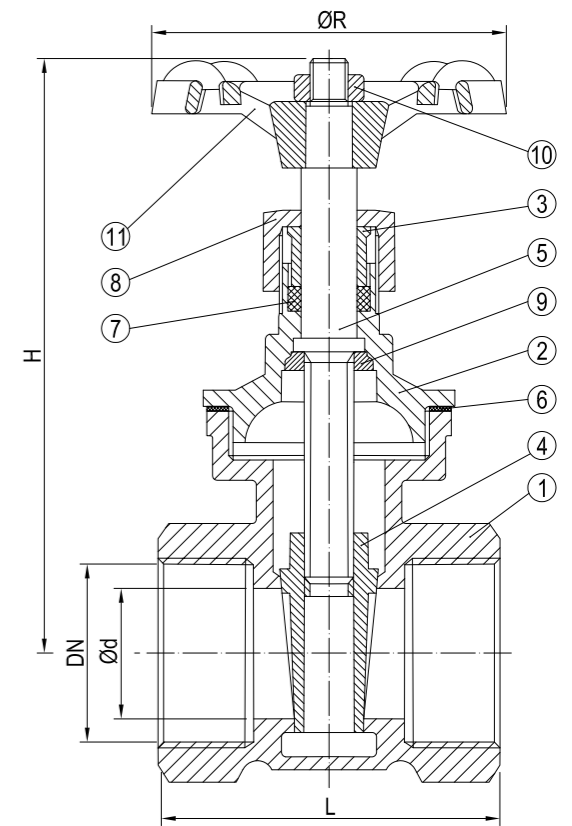
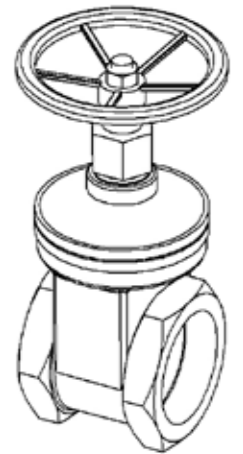

No	Part	Material	Code
1	Body	Bronze	CC491K
2	Bonnet	Brass	OT58
3	Gland	Brass	OT58
4	Wedge	Brass	OT58
5	Stem	Brass	OT58
6	Bonnet Gasket	Heat Resistant Fiber	-
7	Packing	Heat Resistant Fiber	AF/15MA
8	Gland Nut	Brass	OT58
9	Stem Nut	Brass	OT58
10	Nut	Brass	-
11	Handwheel	Steel	-

DN	Inch	L	H	ød	øR	Kg
8	1/4	35	70	11.5	50	0.2
10	3/8	39	68	13	50	0.2
15	1/2	42	74	14	55	0.2
20	3/4	44	79	19	55	0.3
25	1	47	91	24	60	0.4
32	1 1/4	53	112	32	70	0.6
40	1 1/2	58	126	36	80	0.8
50	2	67	143	46.5	90	1.2
65	2 1/2	76	178	60	110	2.1
80	3	82	206	69.5	120	2.8
100	4	96	245	95	140	4.8
125	5	112	312	-	-	10.5
150	6	122	360	-	-	15.3



GATE VALVE

THREADED ENDS

400692
200WOG

DESCRIPTION: AISI 316 body gate valve, AISI 316 wedge.
Non rising stem. BSPP female thread.

APPLICATION: Start/stop flow with minimized pressure drop
for air/gases, water, oils, acidic liquids etc.

STANDARD & DESIGN:

Design Code: -
Inspection Std.: -
End Std.: ISO 228 CLASS A
Face to Face Std.: -
Pressure rating: 200WOG(DN15-DN80)

VARIATIONS: Other dimensions and materials on request.

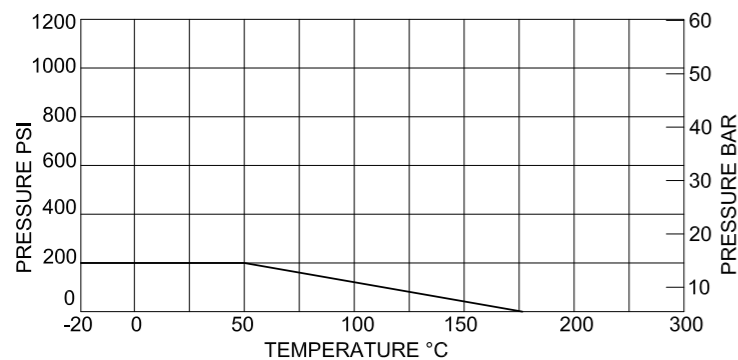
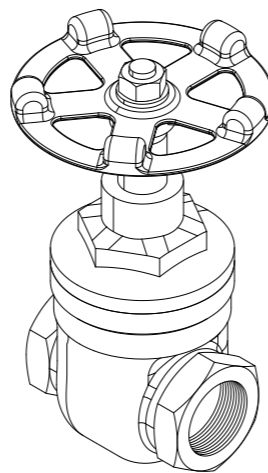

No	Part	Material	Code
1	Body	Stainless Steel	CF8M
2	Bonnet	Stainless Steel	CF8M
3	Gland	Stainless Steel	SUS304
4	Wedge	Stainless Steel	CF8M
5	Stem	Stainless Steel	SUS316
6	Bonnet Gasket	PTFE	-
7	Whorl Gasket	Stainless Steel	SUS304
8	Packing	PTFE	-
9	Cap Nut	Stainless Steel	CF8M
10	Nameplate	Aluminium	-
11	Nut	Stainless Steel	SUS304
12	Handwheel	Aluminium	-

DN	Inch	L	H	ød	øR	Kg
15	1/2	55	101	15	70	0.4
20	3/4	60	108	20	70	0.5
25	1	65	115	25	80	0.7
32	1 1/4	75	132	32	80	1.0
40	1 1/2	85	149	38	90	1.5
50	2	95	175	50	100	2.1
65	2 1/2	116	213	65	140	5.6
80	3	130	241	80	140	8.6

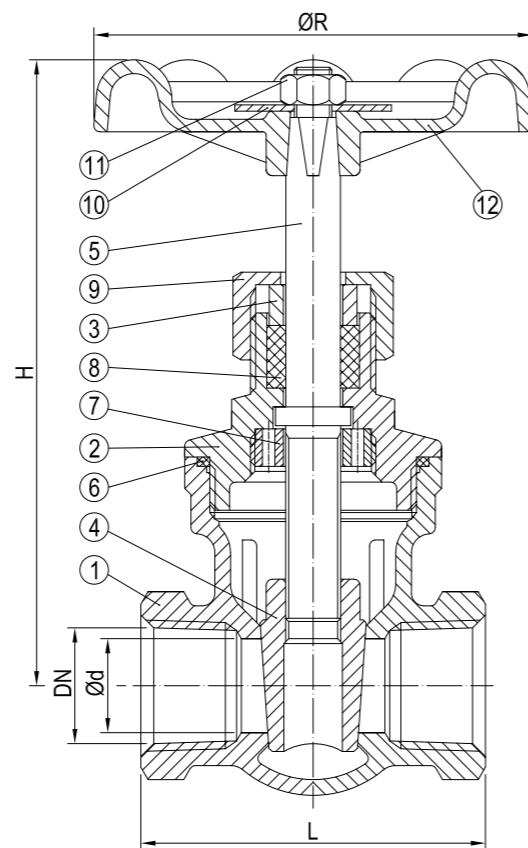

GATE VALVE

FLANGED ENDS

400822
PN16

DESCRIPTION: Rg5 body gate valve, brass wedge.
Non rising stem, screwed bonnet. Flat face flanged.

APPLICATION: Start/stop flow with minimized pressure drop
for air/gases, water, oils etc.

STANDARD & DESIGN:

Design Code: -
Inspection Std.: -
End Std.: -
Face to Face Std.: -
Flanges drilled: PN16(DN15-DN150)
Pressure rating: PN16(DN15-DN150)
Temperature Range: 0°C to 95°C

VARIATIONS: Other dimensions and materials on request.

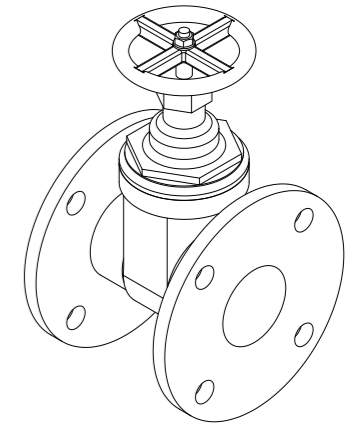

No	Part	Material	Code
1	Body	Bronze	CC491K
2	Bonnet	Bronze	CC491K
3	Wedge	Bronze	CC491K
4	Stem	Brass	CW614N
5	Bonnet Gasket	Heat Resistant Fiber	-
6	Packing	Heat Resistant Fiber	AF/15MA
7	Gland	Brass	CW614N
8	Gland Nut	Brass	CW614N
9	Stem Nut	Brass	CW614N
10	Nut	Brass	CW614N
11	Handwheel	Steel	-

DN	n x ød	Hcd	øD	L	H	øR	Kg
15	4x14	65	95	75	82	50	1.2
20	4x14	75	105	80	103	60	1.8
25	4x14	85	115	90	103	60	2.2
32	4x18	100	140	100	122	70	3.4
40	4x18	110	150	110	132	80	4.2
50	4x18	125	165	125	155	90	5.6
65	4x18	145	185	145	198	110	7.4
80	8x18	160	200	162	237	120	10.0
100	8x18	180	220	170	325	175	15.8
125	8x18	210	250	200	320	175	22.1
150	8x22	240	285	210	355	200	31.5

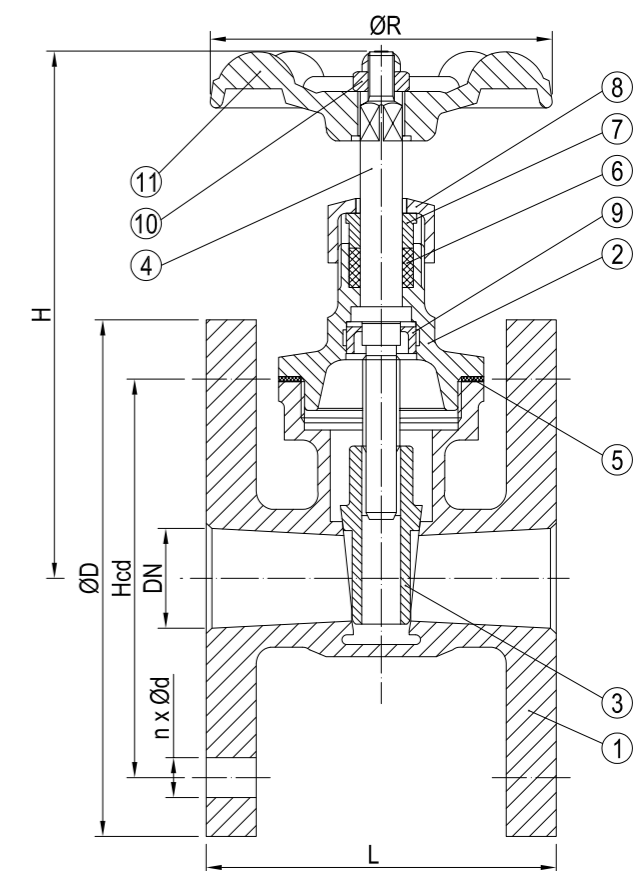



GATE VALVE

FLANGED ENDS

401522/21
PN16/PN10/
PN6/PN4

DESCRIPTION: Rg5 body gate valve. Non rising stem with open/close indicator and bolted bonnet. Flat face flanged. Short F4 type.

APPLICATION: Start/stop flow with minimized pressure drop for water and sea water etc. Suitable as sea direct.

STANDARD & DESIGN:

Design Code:	-
Inspection Std.:	-
End Std.:	-
Face to Face Std.:	-
Flanges drilled:	PN16(DN25-DN150) PN10(DN200-DN350)
Pressure rating:	PN16(DN25-DN150) PN10(DN200) PN6(DN250-DN300) PN4(DN350)

VARIATIONS: With drain plug. With actuator. Stem of CuAl10Ni

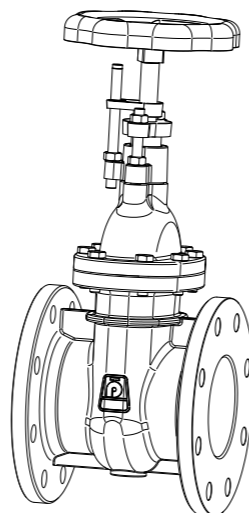

No	Part	Material	Code
1	Body	Bronze	CC 491K
2	Bonnet	Bronze	CC 491K
3	Gland	Bronze	CC 491K
4	Wedge	Bronze	CC 491K
5	Stem	Brass	CW 602N
6	Wedge Nut	Bronze	CC 491K
7	Bonnet Gasket	Dixo 4000	-
8	Stuffing Box	Bronze	CC 491K
9	Stuffing Box Gasket	Dixo 4000	-
10	Gland Packing	PTFE	-
11	Bolt	Stainless Steel	EN 1.4404
12	Stud	Stainless Steel	EN 1.4404
13	Nut	Stainless Steel	EN 1.4404
14	Indicator	Bronze	CC 491K
15	Indicator Pin	Brass	CW 602N
16	Washer	Stainless Steel	EN 1.4404
17	Nut	Stainless Steel	EN 1.4404
18	Handwheel	Cast Iron	EN JS1030

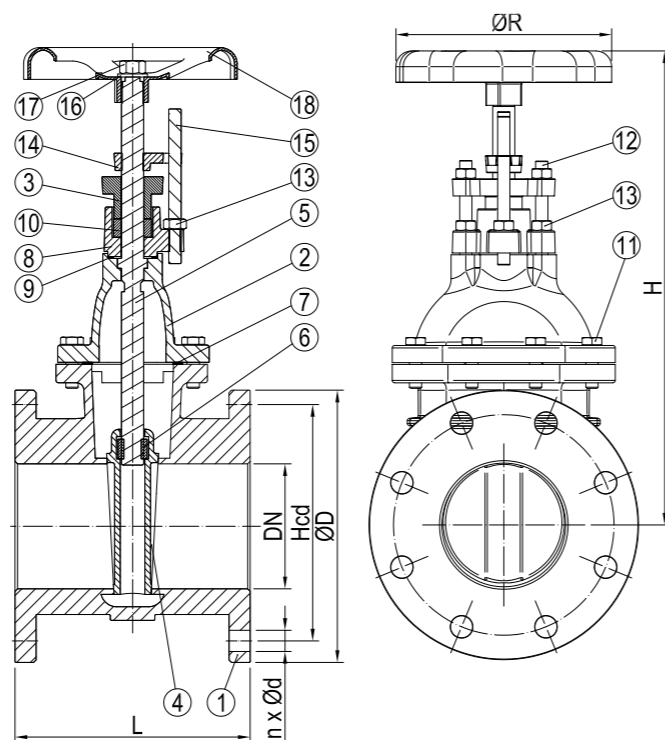

DN	n x ød	Hcd	øD	L	H	Kg
25	4x14	85	115	105	210	5.5
32	4x18	100	140	115	230	7.0
40	4x18	110	150	140	255	10.0
50	4x18	125	165	150	270	11.5
65	4x18	145	185	170	310	15.0
80	8x18	160	200	180	325	17.0
100	8x18	180	220	190	380	21.0
125	8x18	210	250	200	440	29.6
150	8x22	240	285	210	500	41.0
200	8x22	295	340	230	650	72.0
250	12x22	350	395	250	700	114.0
300	12x22	400	445	270	775	138.0
350	16x22	460	505	290	890	260.0



GATE VALVE

FLANGED ENDS

620102/01
PN16/PN10

DESCRIPTION: Nodular cast iron body gate valve with Rg5 trim. Non rising stem with open/close indicator and bolted bonnet. Raised face flanged. Short F4 type.

APPLICATION: Cold and hot water, fresh water, seawater, lubricating oil. Start/stop flow with minimized pressure drop for water, sea water, steam and oils etc. Suitable as sea direct.

VARIATIONS:

With actuator
AISI 304 trim
RG5 wedge disc

STANDARD & DESIGN:

Design Code:	DIN EN 1171(DIN 3352 T2) - with indicator
Inspection Std.:	-
End Std.:	EN 1092-2/B (DIN 2501)
Face to Face Std.:	EN 558 Series 14(DIN 3202 F4)
Flanges drilled:	PN16 (DN15-DN150) PN10 (DN200-DN700)
Pressure rating:	PN16 (DN15-DN150) PN10 (DN200-DN300) PN6 (DN350-DN500) PN4 (DN600-DN700)
Temperature range:	-10°C to +120°C

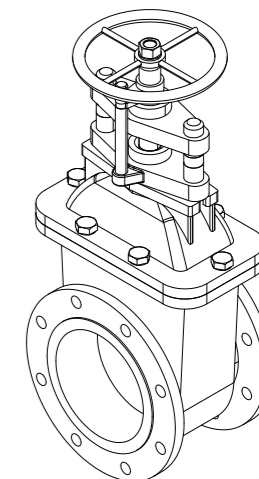

Pressure & Temperature ranges:

Bore	Working Pressure(Bar)	
	120°C	
DN40-DN150	16	
DN200-DN300	10	
DN350-DN500	6	
DN600-DN700	4	

No	Part	Material	Code
1	Body	Nodular Cast Iron	EN-GJS400-18-LT
2	Bonnet	Nodular Cast Iron	EN-GJS400-18-LT
3	Wedge(≤100) (>100)	Bronze Nodular Cast Iron	CuSn5Zn5Pb5-C EN-GJS400-18-LT
4	Seat	Bronze	CuSn5Zn5Pb5-C
5	Stem	Brass	CuZn39Pb3
6	Gland Packing	PTFE	-
7	Bonnet Gasket	Asbestos free	-
8	Stud Bolt	Steel	-
9	Nut	Steel	-
10	Hand Wheel	Cast Iron	EN-GJL250
11	Indicator	Bronze	CuSn5Zn5Pb5-C

DN	n x ød	Hcd	øD	L	H	øR	Kg
40	4x18	110	150	140	270	140	11
50	4x18	125	165	150	270	140	13
65	4x18	145	185	170	295	160	17
80	8x18	160	200	180	325	160	20
100	8x18	180	220	190	360	200	28
125	8x18	210	250	200	450	200	40
150	8x22	240	285	210	500	200	50
200	8x22	295	340	230	620	250	85
250	12x22	350	395	250	730	315	135
300	12x22	400	445	270	845	315	180
350	16x22	460	505	290	930	400	225
400	16x26	515	565	310	1015	400	295
450	20x26	565	615	330	1125	400	350
500	20x26	620	670	350	1275	500	480
600	20x30	725	780	390	1460	500	590
700	24x30	840	895	430	1650	630	780

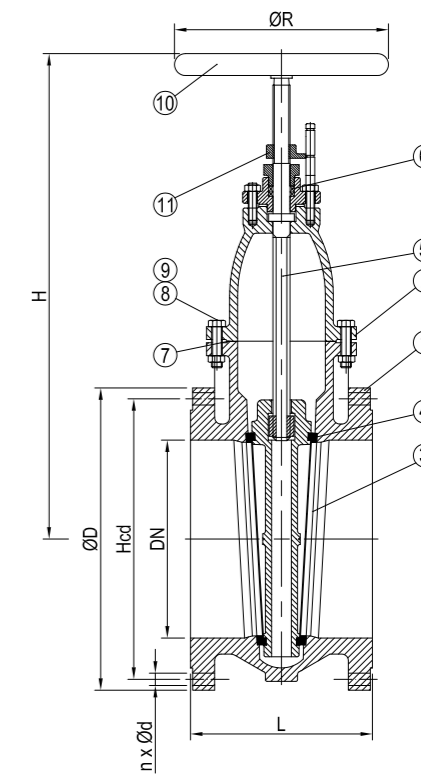



GATE VALVE

FLANGED ENDS

620151
PN10

DESCRIPTION: Grey cast iron body gate valve with Rg5 trim. Non rising stem with open/close indicator and bolted bonnet. Raised face flanged. Short F4 type.

APPLICATION: Cold and hot water, fresh water, seawater, lubricating oil. Start/stop flow with minimized pressure drop for water, sea water and oils etc.

VARIATIONS:
With drain plug
With actuator
AISI 304 trim

STANDARD & DESIGN:

Design Code: DIN EN 1171 (DIN 3352 T2)
- with indicator.
Inspection Std.: -
End Std.: EN 1092-2/B (DIN 2501)
Face to Face Std.: EN 558 Series 14 (DIN 3202 F4)
Flanges drilled: PN10 (DN40-DN700)
Pressure rating: PN10 (DN40-DN200)
PN6 (DN250-DN300)
PN4 (DN350-DN500)
PN2.5 (DN600-DN700)

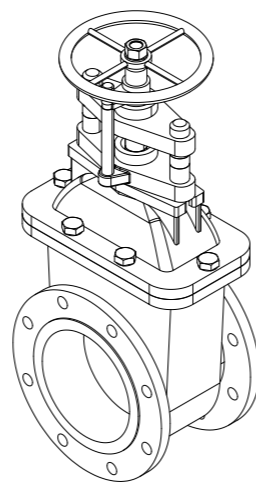

Pressure & Temperature ranges:

Bore	Working Pressure(Bar)	
	120°C	
DN40-DN200	10	
DN250-DN300	6	
DN350-DN500	4	
DN600-DN700	2.5	

No	Part	Material	Code
1	Body	Cast Iron	EN-GJL250
2	Bonnet	Cast Iron	EN-GJL250
3	Wedge (≤100) (>100)	Bronze Cast Iron	CuSn5Zn5Pb5-C EN-GJL250
4	Seat	Bronze	CuSn5Zn5Pb5-C
5	Stem	Brass	CuZn39Pb3
6	Gland Packing	PTFE	-
7	Bonnet Gasket	Asbestos free	-
8	Stud Bolt	Steel	-
9	Nut	Steel	-
10	Hand Wheel	Cast Iron	EN-GJL250
11	Indicator	Bronze	CuSn5Zn5Pb5-C

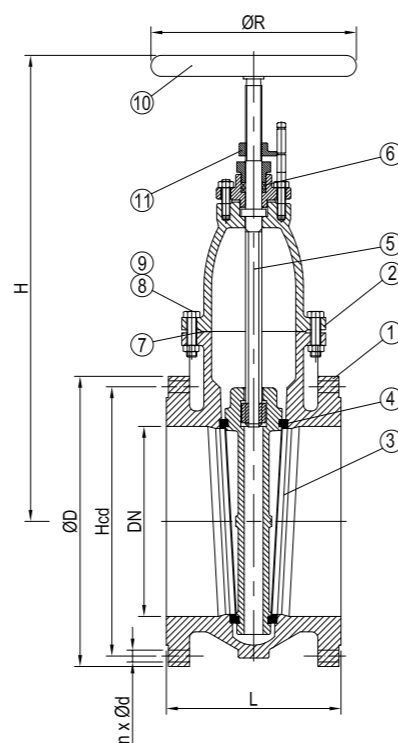

DN	n x ød	Hcd	øD	L	H	øR	Kg
40	4x18	110	150	140	270	140	11
50	4x18	125	165	150	270	140	13
65	8x18	145	185	170	295	160	17
80	8x18	160	200	180	325	160	20
100	8x18	180	220	190	360	200	28
125	8x18	210	250	200	450	200	40
150	8x22	240	285	210	500	200	50
175	8x22	270	315	220	560	200	63
200	8x22	295	340	230	620	250	80
250	12x22	350	395	250	730	315	130
300	12x22	400	445	270	860	315	170
350	16x22	460	505	290	960	400	230
400	16x26	515	565	310	1015	400	295
450	20x26	565	615	330	1125	400	350
500	20x26	620	670	350	1255	500	500
600	20x30	725	780	390	1460	500	615
700	24x30	840	895	430	1715	630	780



GATE VALVE

FLANGED ENDS

620202/01
PN16/PN10

DESCRIPTION: Nodular cast iron body gate valve with Rg5 trim. Non rising stem with open/close indicator and bolted bonnet. Raised face flanged. Long type.

APPLICATION: Cold and hot water, fresh water, seawater, lubricating oil. Start/stop flow with minimized pressure drop for water, sea water, steam and oils etc. Suitable as sea direct.

VARIATIONS: With drain plug
With actuator
AISI 304 trim
Grey cast iron body
Soft seated

STANDARD & DESIGN:

Design Code: DIN EN 1171 (DIN 3352 T2)
- with indicator
Inspection Std.: -
End Std.: EN 1092-2/B (DIN 2501)
Face to Face Std.: EN 558 Series 15 (DIN 3202 F5)
Flanges drilled: PN16 (DN15-DN150)
PN10 (DN200-DN1000)
Pressure rating: PN16 (DN15-DN150)
PN10 (DN200-DN1000)
Temperature range: -10°C to +120°C

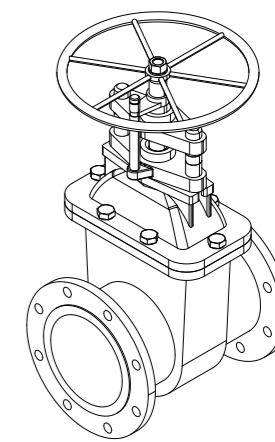

Pressure & Temperature ranges:

Bore	Working Pressure(Bar)	
	120°C	
DN40-DN150	16	
DN200-DN1000	10	

No	Part	Material	Code
1	Body	Nodular Cast Iron	EN-GJS400-15
2	Bonnet	Nodular Cast Iron	EN-GJS400-15
3	Wedge	Nodular Cast Iron	EN-GJS400-15
4	Seat	Bronze	CuSn5Zn5Pb5-C
5	Stem	Stainless Steel	X20Cr13(1.4021)
6	Gland Packing	PTFE	-
7	Bonnet Gasket	Asbestos free	-
8	Stud Bolt	Steel	-
9	Nut	Steel	-
10	Hand Wheel	Cast Iron	EN-GJL250
11	Indicator	Bronze	CuSn5Zn5Pb5-C

DN	n x ød	Hcd	øD	L	H	øR	Kg
40	4x18	110	150	240	310	200	13
50	4x18	125	165	250	310	200	14
65	4x18	145	185	270	360	250	19
80	8x18	160	200	280	380	250	25
100	8x18	180	220	300	430	315	30
125	8x18	210	250	325	495	315	48
150	8x22	240	285	350	545	315	60
200	8x22	295	340	400	625	400	97
250	12x22	350	395	450	680	500	165
300	12x22	400	445	500	900	500	235
350	16x22	460	505	550	995	500	330
400	16x26	515	565	600	1060	630	440
450	20x26	565	615	650	1225	630	585
500	20x26	620	670	700	1320	800	787
600	20x30	725	780	800	1485	800	1060
700	24x30	840	895	900	1685	800	1330
800	24x33	950	1015	1000	1900	800	2300
900	28x33	1050	1115	1100	2125	1000	3400
1000	28x36	1160	1230	1200	2400	1000	4300

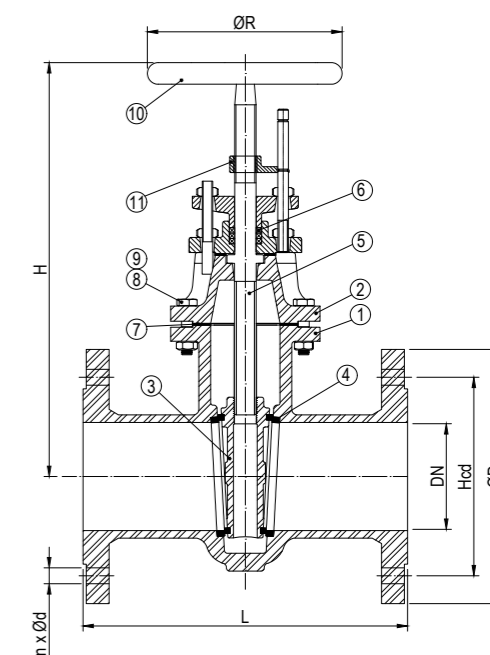



GATE VALVE

FLANGED ENDS

620302/01
PN 16/PN10

DESCRIPTION: Nodular cast iron body gate valve with EPDM coated wedge. Non rising stem and bolted bonnet. Raised face flanged. F4 short type.

APPLICATION: Approved for drinking water systems - Hygienic certificate.

STANDARD & DESIGN:

Design Code: -
 Inspection Std.: EN 12266-1
 End Std.: EN 1092-2
 Face to Face Std.: Series F4 acc. to DIN 3202
 Flanges drilled: PN16 (DN40-DN150)
 PN10 (DN200-DN300)
 Pressure rating: PN16 (DN40-DN150)
 PN10 (DN200-DN300)

VARIATIONS: DN200-DN300 available PN16

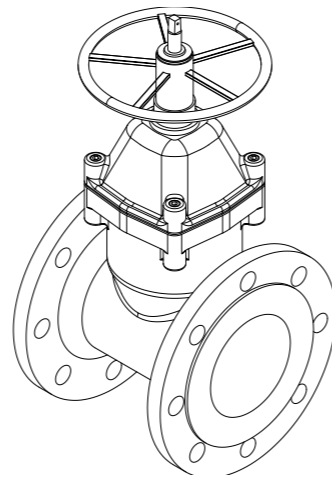

No	Part	Material	Code
1	Body	Nodular Cast Iron	EN-GJS-500-7 5.3200
2	Cover	Nodular Cast Iron	EN-GJS-500-7 5.3200
3	Mandrel	Stainless steel	X20Cr13
4	Seal	EPDM	-
5	Protective Ring	Stainless steel	X5CrNi18-10
6	Screw Plug	Brass	CuZn39Pb1
7,8	O-ring	EPDM or NBR	-
9	Lower pad	Polyamide PA6	-
10	Lower Seal	EPDM or NBR	-
11	Cover Screw	Galvanised Steel	-
12	Retaining nut	Brass	CuZn39Pb1
13	Cover seal	EPDM lub/or NBR	-
14	Nut	Brass	CuZn39Pb1
15	Wedge	EPDM or NBR	-
16	Handweel	Cast Iron	-

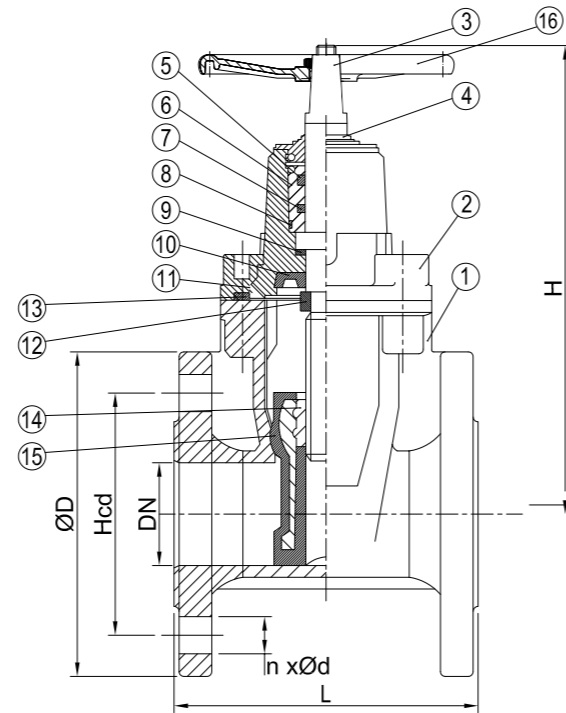

DN	n x ød	Hcd	øD	L	H	Kg
40	4x19	110	150	140	245	9.2
50	4x19	125	165	150	270	10.7
65	4x19	145	185	170	300	15.4
80	8x19	160	200	180	320	17.2
100	8x19	180	220	190	370	22.0
125	8x19	210	250	200	410	28.0
150	8x23	240	285	210	450	33.3
200	8x23	295	340	230	540	60.0
250	12x23	350	395	250	640	98.0
300	12x23	400	445	270	720	125.0



GATE VALVE

FLANGED ENDS

620762
PN16

DESCRIPTION: Cast steel body gate valve with stellite coated steel wedge and stellite coated seat. Rising stem and bolted bonnet. Raised face flanged. Long type.

APPLICATION: Start/stop flow with minimized pressure drop for water, steam, oils and aggressive/abrasive media etc.

STANDARD & DESIGN:

Design Code: EN 1984
 Inspection Std.: EN 12266-1
 End Std.: EN 1092-1
 Face to Face Std.: EN 558-1
 Flanges drilled: PN16 (DN40-DN500)
 Pressure rating: PN16 (DN40-DN500)

VARIATIONS: With drain plug. With actuator
 Other dimensions and materials on request.

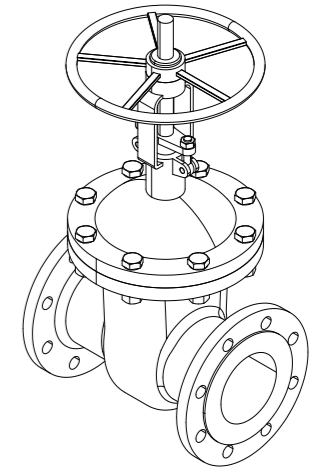

No	Part	Material	Code
1	Body	Cast Steel	ASTM A216-WCB
2	Bonnet	Cast Steel	ASTM A216-WCB
3	Wedge	Cast Steel	ASTM A216-WCB
4	Seat	Deposited Stellite	-
5	Stem	Stainless Steel	ASTM A182-F6a
6	Bonnet Gasket	Graphite	-
7	Stud Bolt	Steel	ASTM A193 Gr.B7
8	Nut	Steel	ASTM A194 Gr.2H
9	Back Seat	Deposited Stellite	-
10	Packing	Graphite	-
11	Yoke	Cast Steel	ASTM A216-WCB
12	Stem Nut	Al-Bronze alloy	-
13	Axle tree	Steel	E51100
14	Handwheel	Cast Iron	-

DN	n x ød	Hcd	øD	L	H	H _{max}	øR	Kg
40	4x18	110	150	240	300	352	200	26.5
50	4x18	125	165	250	358	438	240	29
65	4x18	145	185	270	375	450	240	33
80	8x18	160	200	280	433	528	280	45
100	8x18	180	220	300	502	620	320	63
125	8x18	210	250	325	612	753	360	108
150	8x22	240	285	350	676	847	360	134
200	12x22	295	340	400	820	1039	400	192
250	12x26	355	405	450	969	1245	450	273
300	12x26	410	460	500	1142	1472	560	379
350	16x26	470	520	550	1280	1450	640	590
400	16x30	525	580	600	1452	1887	640	850
450	20x30	585	640	650	1541	2011	720	907
500	20x33	650	715	700	1676	2181	720	958

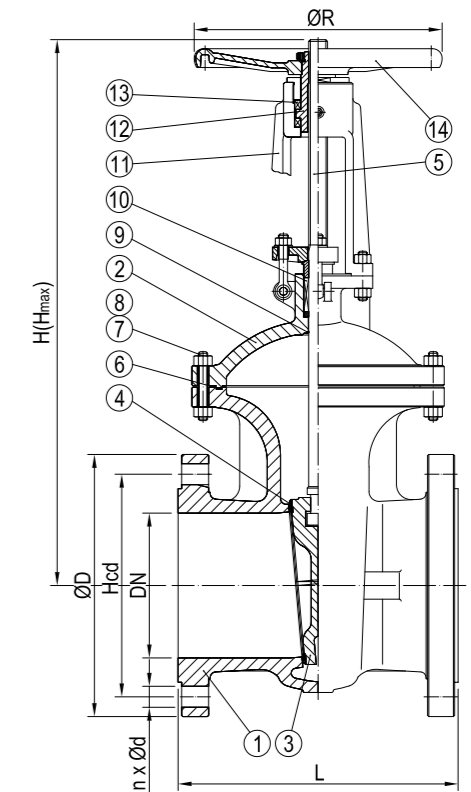



GATE VALVE

FLANGED ENDS

620762-F4
PN16

DESCRIPTION: Cast steel body gate valve with stellite coated steel wedge and stellite coated seat. Rising stem and bolted bonnet. Raised face flanged. F4 short type.

APPLICATION: Start/stop flow with minimized pressure drop for water, steam, oils and aggressive/abrasive media etc.

STANDARD & DESIGN:

Design Code: EN 1984
 Inspection Std.: EN 12266-1
 End Std.: EN 1092-1
 Face to Face Std.: EN 558-1
 Flanges drilled: PN16(DN40-DN400)
 Pressure rating: PN16(DN40-DN400)

VARIATIONS: With drain plug.

With actuator
 Other dimensions and materials on request.

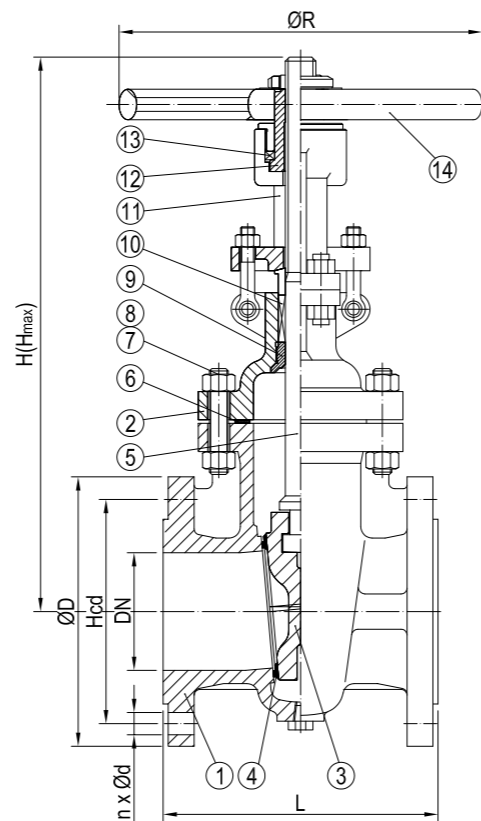
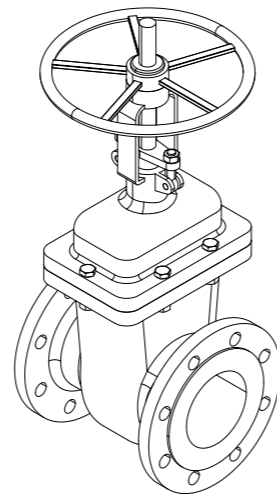

No	Part	Material	Code
1	Body	Cast Steel	ASTM A216-WCB
2	Bonnet	Cast Steel	ASTM A216-WCB
3	Wedge	Cast Steel	ASTM A216-WCB
4	Seat	Deposited Stellite	-
5	Stem	Stainless Steel	ASTM A182-F6a
6	Bonnet Gasket	Graphite	-
7	Stud Bolt	Steel	ASTM A193 Gr.B7
8	Nut	Steel	ASTM A194 Gr.2H
9	Back Seat Bushing	Stainless Steel	ASTM A276-420
10	Packing	Graphite	-
11	Yoke	Cast Steel	ASTM A216-WCB
12	Stem Nut	Al-Bronze alloy	-
13	Axel tree	Steel	E51100
14	Handwheel	Cast Iron	-

DN	n x ød	Hcd	øD	L	H	H _{max}	øR	Kg
40	4x18	110	150	140	300	352	200	26.5
50	4x18	125	165	150	358	438	240	29
65	4x18	145	185	170	375	450	240	33
80	8x18	160	200	180	433	528	280	45
100	8x18	180	220	190	502	620	320	63
125	8x18	210	250	200	612	753	380	108
150	8x22	240	285	210	676	847	380	134
200	12x22	295	340	230	820	1039	400	192
250	12x26	355	405	250	969	1245	450	273
300	12x26	410	460	270	1142	1472	580	379
350	16x26	470	520	290	1280	1450	640	590
400	16x30	525	580	310	1452	1887	640	850



GATE VALVE

FLANGED ENDS

620763
PN25

DESCRIPTION: Cast steel body gate valve with stellite coated steel wedge and stellite coated seat. Rising stem and bolted bonnet. Raised face flanged. Long type.

APPLICATION: Start/stop flow with minimized pressure drop for water, steam, oils and aggressive media etc.

STANDARD & DESIGN:

Design Code: EN 1984
 Inspection Std.: EN 12266-1
 End Std.: EN 1092-1
 Face to Face Std.: EN 558-1
 Flanges drilled: PN25(DN40-DN500)
 Pressure rating: PN25(DN40-DN500)

VARIATIONS: With drain plug.

With actuator
 Other dimensions and materials on request.

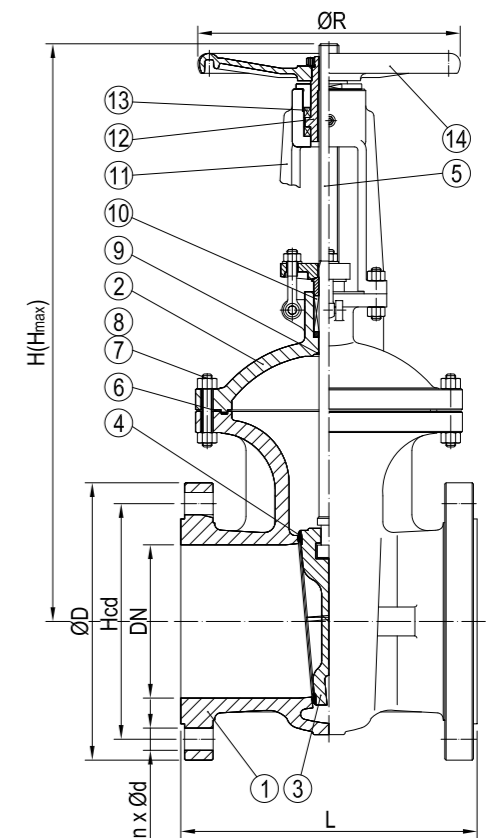
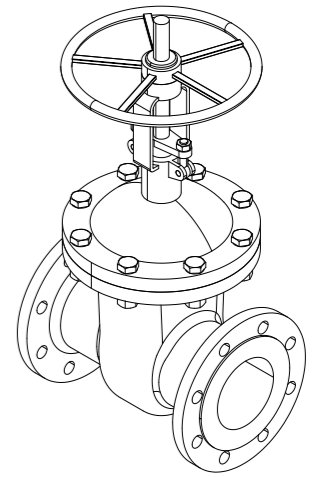

No	Part	Material	Code
1	Body	Cast Steel	ASTM A216-WCB
2	Bonnet	Cast Steel	ASTM A216-WCB
3	Wedge	Cast Steel	ASTM A216-WCB
4	Seat	Deposited Stellite	-
5	Stem	Stainless Steel	ASTM A182-F6a
6	Bonnet Gasket	Graphite	-
7	Stud Bolt	Steel	ASTM A193 Gr.B7
8	Nut	Steel	ASTM A194 Gr.2H
9	Back Seat	Deposited Stellite	-
10	Packing	Graphite	-
11	Yoke	Cast Steel	ASTM A216-WCB
12	Stem Nut	Al-Bronze alloy	-
13	Axel tree	Steel	E51100
14	Handwheel	Cast Iron	-

DN	n x ød	Hcd	øD	L	H	H _{max}	øR	Kg
40	4x18	110	150	240	300	352	200	18
50	4x18	125	165	250	358	438	240	28
65	8x18	145	185	270	375	450	240	33
80	8x18	160	200	280	433	528	280	46
100	8x22	190	235	300	502	620	320	64
125	8x26	220	270	325	612	753	360	116
150	8x26	250	300	350	676	847	360	141
200	12x26	310	360	400	820	1039	400	213
250	12x30	370	425	450	969	1245	450	290
300	16x30	430	485	500	1142	1472	560	400
350	16x33	490	555	550	1280	1450	640	631
400	16x36	550	620	600	1452	1887	640	900
450	20x36	600	660	650	1541	2011	720	1013
500	20x36	660	730	700	1676	2181	720	1166



GATE VALVE

FLANGED ENDS

620764
PN40

DESCRIPTION: Cast steel body gate valve with stellite coated steel wedge and stellite coated seat. Rising stem and bolted bonnet. Raised face flanged. Long type.

APPLICATION: Start/stop flow with minimized pressure drop for water, steam, oils and aggressive/abrasive media etc.

STANDARD & DESIGN:

Design Code: EN 1984
 Inspection Std.: EN 12266-1
 End Std.: EN 1092-1
 Face to Face Std.: EN 558-1
 Flanges drilled: PN40(DN40-DN500)
 Pressure rating: PN40(DN40-DN500)

VARIATIONS: With drain plug
 With actuator
 Other dimensions and materials on request.

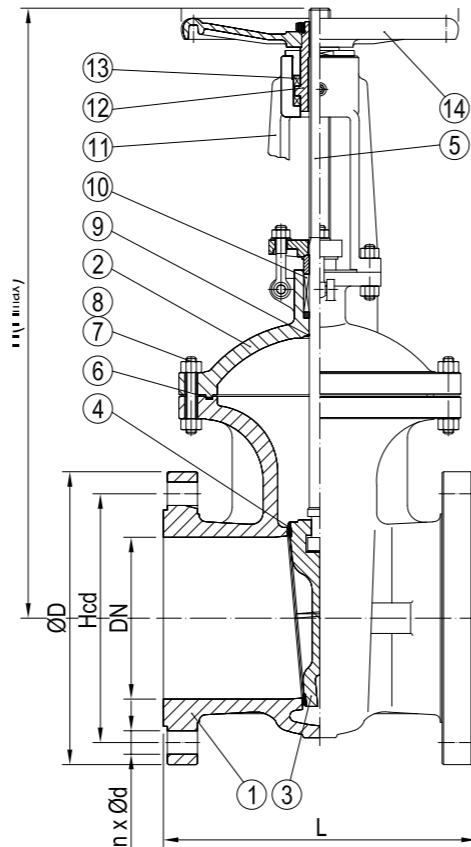
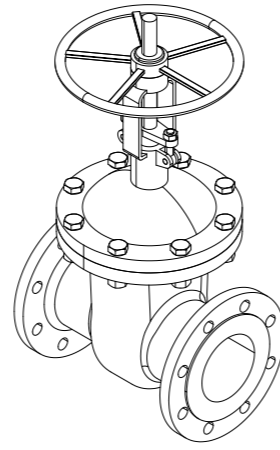

No	Part	Material	Code
1	Body	Cast Steel	ASTM A216-WCB
2	Bonnet	Cast Steel	ASTM A216-WCB
3	Wedge	Cast Steel	ASTM A216-WCB
4	Seat	Deposited Stellite	-
5	Stem	Stainless Steel	ASTM A182-F6a
6	Bonnet Gasket	Graphite	-
7	Stud Bolt	Steel	ASTM A193 Gr.B7
8	Nut	Steel	ASTM A194 Gr.2H
9	Back Seat	Deposited Stellite	-
10	Packing	Graphite	-
11	Yoke	Cast Steel	ASTM A216-WCB
12	Stem Nut	Al-Bronze alloy	-
13	Axle tree	Steel	E51100
14	Handwheel	Cast Iron	-

DN	n x ød	Hcd	øD	L	H	H _{max}	øR	Kg
40	4x18	110	150	240	323	369	200	29
50	4x18	125	165	250	372	440	280	32
65	8x18	145	185	290	395	473	280	39
80	8x18	160	200	310	457	552	320	52
100	8x22	190	235	350	552	671	360	80
125	8x26	220	270	400	634	728	400	127
150	8x26	250	300	450	708	883	400	154
200	12x30	320	375	550	858	1086	450	263
250	12x33	385	450	650	1015	1298	560	368
300	16x33	450	515	750	1203	1535	640	547
350	16x36	510	580	850	1341	1678	640	679
400	16x39	585	660	950	1492	1903	720	953
450	20x39	610	685	1050	1583	2215	800	1253
500	20x42	670	755	1150	1792	2580	950	1589



GATE VALVE

FLANGED ENDS

620765
PN63

DESCRIPTION: Cast steel body gate valve with stellite coated steel wedge and stellite coated seat. Rising stem and bolted bonnet. Raised face flanged. Long type.

APPLICATION: Start/stop flow with minimized pressure drop for water, steam, oils and aggressive/abrasive media etc.

STANDARD & DESIGN:

Design Code: EN 1984
 Inspection Std.: EN 12266-1
 End Std.: EN 1092-1
 Face to Face Std.: EN 558-1
 Flanges drilled: PN63(DN40-DN300)
 Pressure rating: PN63(DN40-DN300)

VARIATIONS: With drain plug
 With actuator
 Other dimensions and materials on request.

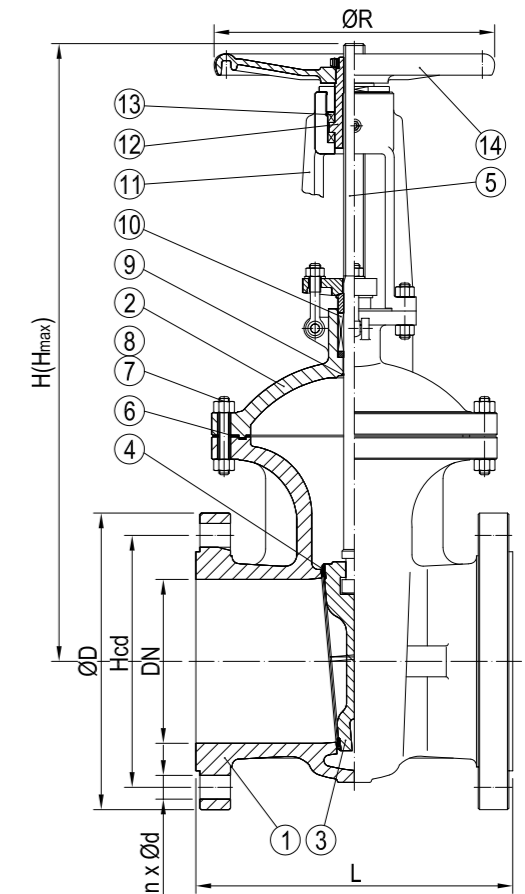
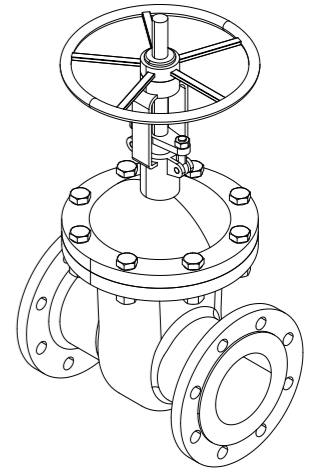

No	Part	Material	Code
1	Body	Cast Steel	ASTM A216-WCB
2	Bonnet	Cast Steel	ASTM A216-WCB
3	Wedge	Cast Steel	ASTM A216-WCB
4	Seat	Deposited Stellite	-
5	Stem	Stainless Steel	ASTM A182-F6a
6	Bonnet Gasket	Graphite	-
7	Stud Bolt	Steel	ASTM A193 Gr.B7
8	Nut	Steel	ASTM A194 Gr.2H
9	Back Seat	Deposited Stellite	-
10	Packing	Graphite	-
11	Yoke	Cast Steel	ASTM A216-WCB
12	Stem Nut	Al-Bronze alloy	-
13	Axle tree	Steel	E51100
14	Handwheel	Cast Iron	-

DN	n x ød	Hcd	øD	L	H	H _{max}	øR	Kg
40	4x22	125	170	240	360	389	240	29
50	4x22	135	180	250	372	448	280	34
65	8x22	160	205	290	395	475	280	43
80	8x22	170	215	310	458	553	320	60
100	8x26	200	250	350	553	679	360	89
125	8x30	240	295	400	638	779	400	140
150	8x33	280	345	450	718	893	450	207
200	12x36	345	415	550	873	1100	560	325
250	12x36	400	470	650	1053	1332	640	467
300	16x36	460	530	750	1203	1535	640	590



GATE VALVE

FLANGED ENDS

620766
PN100

DESCRIPTION: Cast steel body gate valve with stellite coated steel wedge and stellite coated seat. Rising stem and bolted bonnet. Raised face flanged. Long type.

APPLICATION: Start/stop flow with minimized pressure drop for water, steam, oils and aggressive/abrasive media etc.

STANDARD & DESIGN:

Design Code: EN 1984
 Inspection Std.: EN 12266-1
 End Std.: EN 1092-1
 Face to Face Std.: EN 558-1
 Flanges drilled: PN100(DN40-DN200)
 Pressure rating: PN100(DN40-DN200)

VARIATIONS: With drain plug.

With actuator

Other dimensions and materials on request.

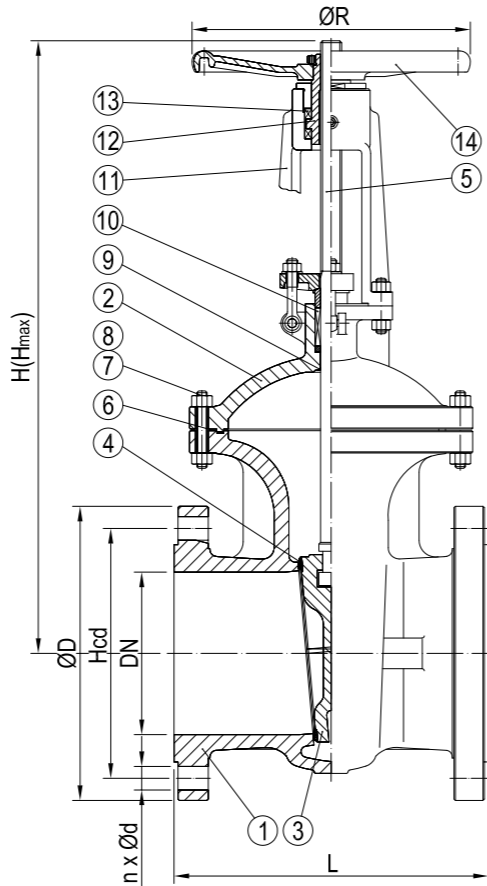
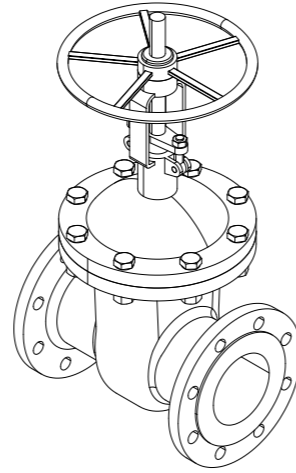

No	Part	Material	Code
1	Body	Cast Steel	ASTM A216-WCB
2	Bonnet	Cast Steel	ASTM A216-WCB
3	Wedge	Cast Steel	ASTM A216-WCB
4	Seat	Deposited Stellite	-
5	Stem	Stainless Steel	ASTM A182-F6a
6	Bonnet Gasket	Graphite	-
7	Stud Bolt	Steel	ASTM A193 Gr.B7
8	Nut	Steel	ASTM A194 Gr.2H
9	Back Seat	Deposited Stellite	-
10	Packing	Graphite	-
11	Yoke	Cast Steel	ASTM A216-WCB
12	Stem Nut	Al-Bronze alloy	-
13	Axle tree	Steel	E51100
14	Handwheel	Cast Iron	-

DN	n x ød	Hcd	øD	L	H	H _{max}	øR	Kg
40	4x22	125	170	240	360	389	280	51
50	4x26	145	195	250	490	558	360	60
65	8x26	170	220	290	540	622	400	70
80	8x26	180	230	310	573	671	400	89
100	8x30	210	265	350	575	671	400	130
125	8x33	250	315	400	744	892	560	223
150	12x33	290	355	450	800	972	560	295
200	12x36	360	430	550	800	972	560	559



GATE VALVE

FLANGED ENDS

621792
PN16

DESCRIPTION: AISI 316 equivalent body gate valve, AISI 316 equivalent wedge. Rising stem. Raised face flanged. F4 short type.

APPLICATION: Start/stop flow with minimized pressure drop for air/gases, steam, water, oils, acidic media etc.

VARIATIONS: Other dimensions and materials on request.

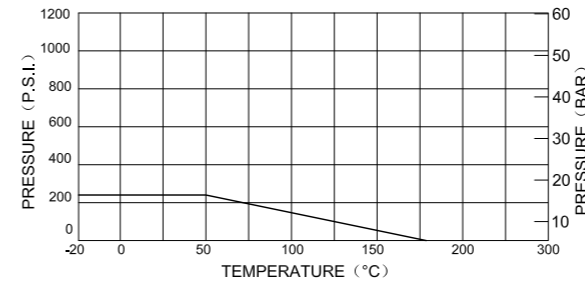

STANDARD & DESIGN:

Design Code: ANSI B16.34
 Inspection Std.: EN 12266-1
 End Std.: DIN 2633
 Face to Face Std.: DIN 3202-F4
 Flanges drilled: PN16(DN15-DN300)
 Pressure rating: PN16(DN15-DN300)

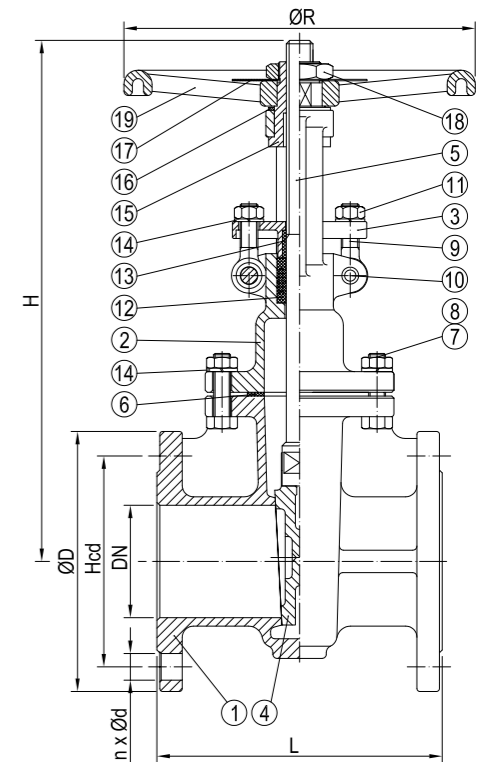
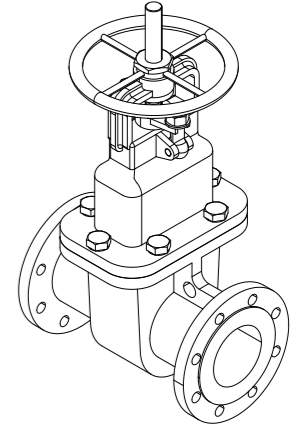

No	Part	Material	Code
1	Body	Stainless Steel	1.4408
2	Bonnet	Stainless Steel	1.4408
3	Gland	Stainless Steel	1.4308
4	Wedge	Stainless Steel	1.4408
5	Stem	Stainless Steel	SUS316
6	Bonnet Gasket(≤DN100) (≥DN125)	PTFE Graphite + SS304	-
7	Stud Bolt	Stainless Steel	SUS304
8	Nut	Stainless Steel	SUS304
9	Eye Bolt	Stainless Steel	SUS304
10	Hinge Pin	Stainless Steel	SUS304
11	Eye Nut	Stainless Steel	SUS304
12	Gland Packing	PTFE	-
13	Stem Bushing	PTFE	-
14	Spring Washers	Stainless Steel	SUS304
15	Yoke Sleeve	Bronze	-
16	Gasket	Bronze	-
17	Name Plate	Stainless Steel	SUS304
18	Nut	Bronze	-
19	Handwheel	Cast Iron	FCD

DN	n x ød	Hcd	øD	L	H	øR	Kg
15	4x14	65	95	115	190	120	3.6
20	4x14	75	105	120	195	120	4.3
25	4x14	85	115	125	234	120	5.2
32	4x18	100	140	130	297	200	8.6
40	4x18	110	150	140	300	200	9.4
50	4x18	125	165	150	330	200	11.6
65	4x18	145	185	170	393	200	15.8
80	8x18	160	200	180	470	250	22.0
100	8x18	180	220	190	545	250	28.6
125	8x18	210	250	200	640	300	45.5
150	8x22	240	285	210	740	300	54.7
200	12x22	295	340	230	910	350	71.0
250	12x26	355	405	250	1097	400	94.6
300	12x26	410	460	270	1285	400	183.6



FIRE HOSE VALVES

Used in fire extinguishing system for quick connection of fire hoses.
Available in straight, angle or oblique pattern.
Available with all types of couplings.
Metal to metal sealing or soft sealing.



FIRE HOSE VALVE

30° ANGLE TYPE

355922
PN16

DESCRIPTION: Rg5 body soft sealing fire valve. Rising stem with screwed and secured bonnet. Angled (30° from flange) hose connection. Flat face flanged.

APPLICATION: Water and sea water hose connection for fire fighting system.

STANDARD & DESIGN:

Design Code: -
 Inspection Std.: -
 End Std.: Inlet EN 1092-3/A(DIN 2501)
 Outlet BSP male threaded
 Face to Face Std.: -
 Flange drilled: PN16(DN40-DN65)
 Pressure rating: PN16(DN40-DN65)
 Temperature Range: -10°C to 60°C

VARIATIONS: Other materials on request.
 With various couplings.

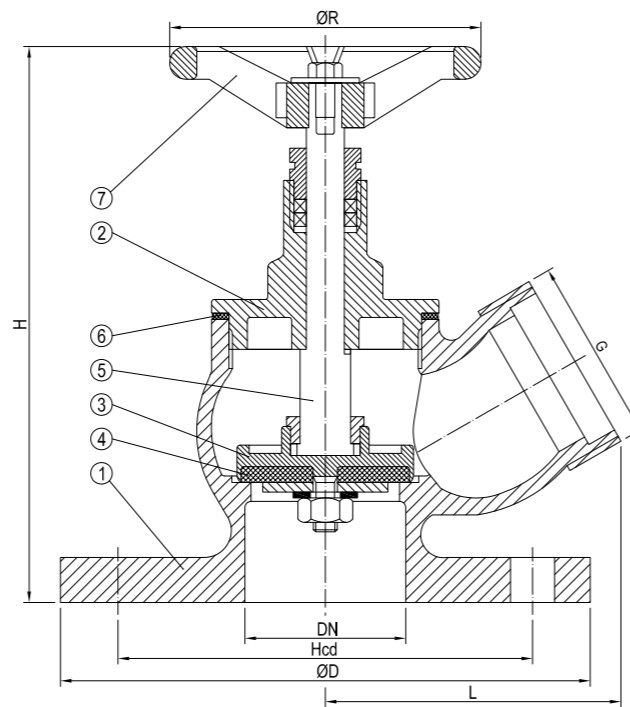
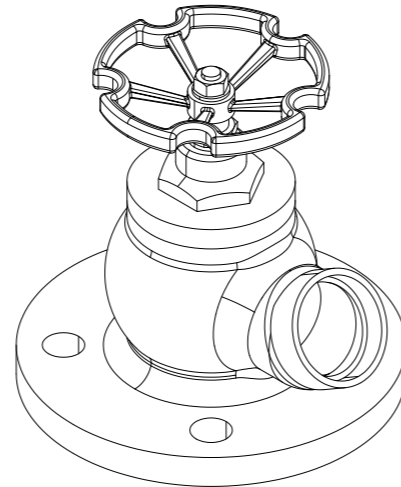

No	Part	Material	Code
1	Body	Bronze	CuSn5Zn5Pb5-C
2	Bonnet	Brass	CuZn39Pb 3
3	Disc	Brass	CuZn35Ni
4	Seat disc	NBR	-
5	Stem	Brass	CuZn35Ni
6	Bonnet Gasket	Asbestos free	-
7	Handwheel	Cast Iron	EN-GJL-250

DN	n x ød	Hcd	øD	G	L	H	øR	Kg
40	4x18	110	150	1 1/2"	80	185	80	3.4
50	4x18	125	165	2"	100	195	100	4.4
65	4x18	145	185	2 1/2"	105	230	120	5.4



FIRE HOSE VALVE

STRAIGHT TYPE

356622
PN 16

DESCRIPTION: Rg5 body soft sealing fire valve. Rising stem with screwed and secured bonnet. Straight hose connection. Raised face flanged.

APPLICATION: Water and sea water hose connection for fire fighting system.

STANDARD & DESIGN:

Design Code: DIN 86211-without coupling
 End Std.(Inlet Flange): EN 1092-3/B(DIN 2501)
 (Outlet Flange): BSP-Male threaded acc. to ISO 228/1
 Face to Face Std.: DIN 86211-straight type
 Flanges drilled: PN16 (DN40-DN65)
 Pressure rating: PN16 (DN40-DN65)
 Temperature range: -10°C to +60°C

VARIATIONS: Special flange drilling acc. to ANSI or JIS.
 Other materials on request.
 With various couplings.

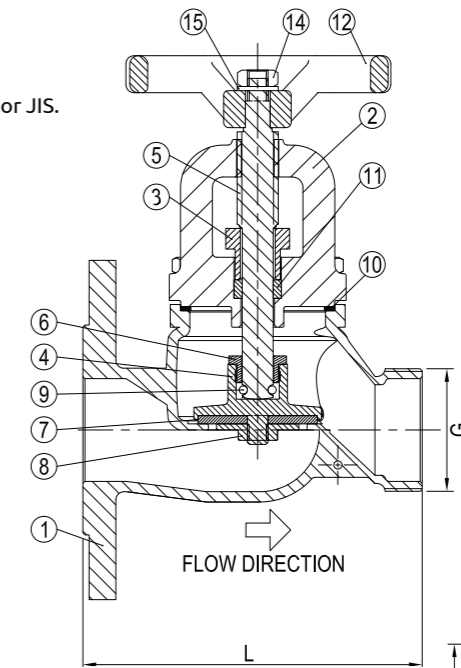
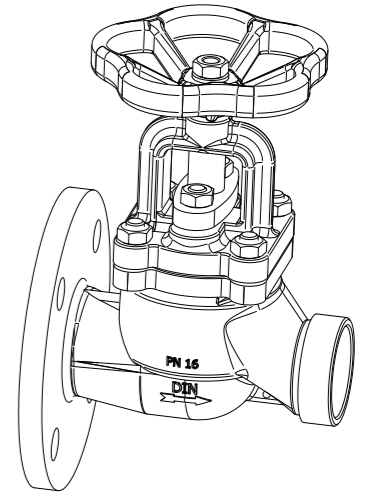

No	Part	Material	Code
1	Body	Bronze	CC 491 K
2	Bonnet	Bronze	CC 490 K
3	Gland	Bronze	CC 491 K
4	Disc	Bronze	CC 491 K
5	Stem	Brass	CW 602 N
6	Disc Nut	Brass	CW 602 N
7	Disc Packing	NBR	-
8	Nut	Bronze	CC491 K
9	Fixing Ring	Copper	Cu
10	Bonnet Packing	NBR	-
11	Gland Packing	PTFE	-
12	Handwheel	Bronze	CC 491 K
13	Stud	Stainless steel	EN 1.4404
14	Nut	Stainless steel	EN 1.4404
15	Washer	Stainless steel	EN 1.4404

DN	n x ød	Hcd	øD	G	L	H	øR	Kg
40	4x18	110	150	1 1/2"	165	165	130	6.0
50	4x18	125	165	2"	165	165	130	6.0
65	4x18	145	185	2 1/2"	200	185	150	10.9



FIRE HOSE VALVE

ANGLE TYPE

356722
PN 16

DESCRIPTION: Rg5 body soft sealing fire valve. Screwed and secured bonnet. 90° hose connection angle. Raised face flanged.

APPLICATION: Water and sea water hose connection for fire fighting system.

STANDARD & DESIGN:

Design Code: DIN 86211-without coupling
 End Std.(Inlet Flange): EN 1092-3/B(DIN 2501)
 (Outlet Flange): BSP-Male threaded acc. to ISO 228/1
 Face to Face Std.: DIN 86211-angle type
 Flanges drilled: PN16 (DN40-DN65)
 Pressure rating: PN16 (DN40-DN65)
 Temperature range: -10°C to +60°C

VARIATIONS: Special flange drilling acc. to ANSI or JIS.
 Other materials on request.
 With various couplings.

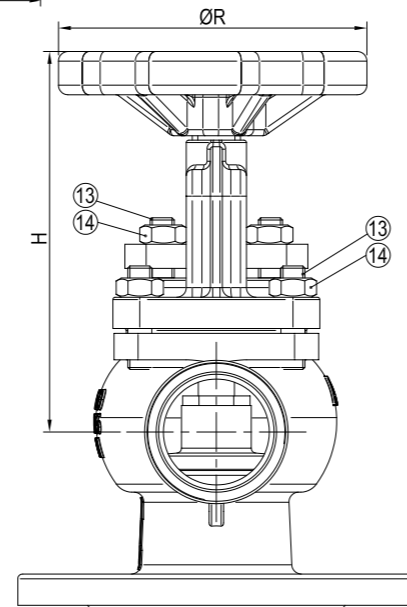
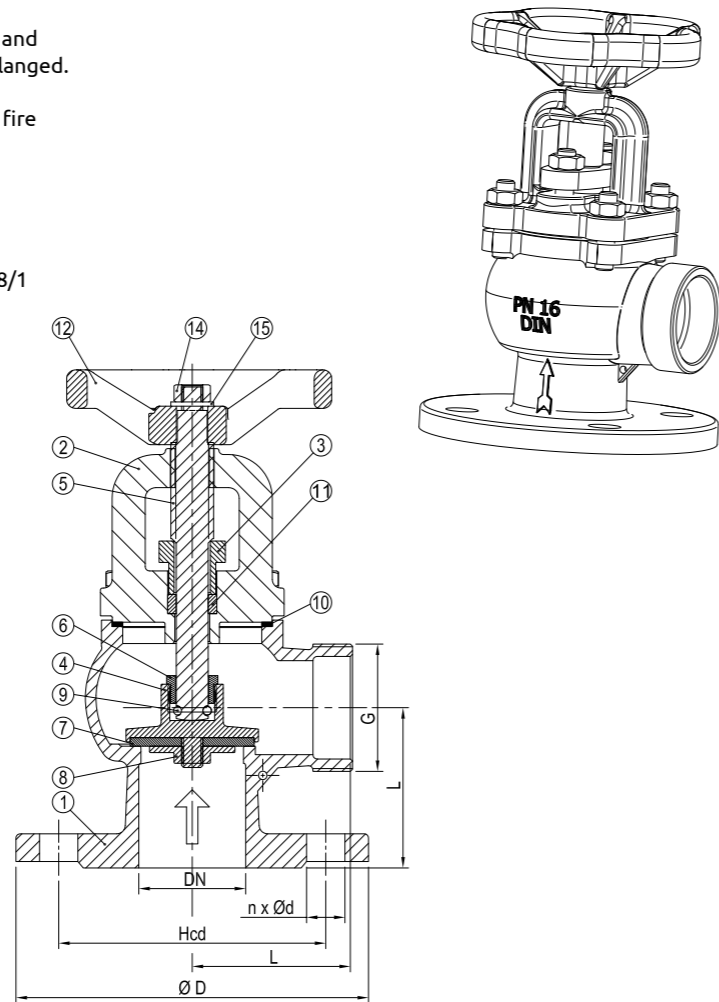

No	Part	Material	Code
1	Body	Bronze	CC 491 K
2	Bonnet	Bronze	CC 491 K
3	Gland	Bronze	CC 491 K
4	Disc	Bronze	CC 491 K
5	Stem	Brass	CW 602 N
6	Disc Nut	Brass	CW 602 N
7	Disc Packing	NBR	-
8	Nut	Bronze	CC491 K
9	Fixing Ring	Copper	Cu
10	Bonnet Packing	NBR	-
11	Gland Packing	PTFE	-
12	Handwheel	Bronze	CC 491 K
13	Stud	Stainless steel	EN 1.4404
14	Nut	Stainless steel	EN 1.4404
15	Washer	Stainless steel	EN 1.4404

DN	n x ød	Hcd	øD	G	L	H	øR	Kg
40	4x18	110	150	1½	75	135	130	5.3
50	4x18	125	165	2	75	145	130	5.7
65	4x18	145	185	2½	95	165	150	10.2



BUTTERFLY VALVES

For shut off or regulating purposes. Centric type or double-eccentric type suitable for high demands. Available as wafer type to be mounted between flanges. Lug type with threaded holes which allows valve to be used as end-of-line valve. Also available with double-flanged connections. Metal to metal sealing or soft sealing. Available with different types of actuators.



BUTTERFLY VALVE

WAFER TYPE

700702/01
PN16/PN10

DESCRIPTION: Nodular cast iron body, vulcanized liner wafer type butterfly valve with Al Bronze disc. Centric free stem with standardized pattern for actuator mounting.

APPLICATION: Start/stop of flow: Sea water, water etc.

STANDARD & DESIGN:

Design Code: API 609
 Inspection Std.: API 598
 End Std.: DIN 2501 PN16
 DIN 2501 PN10
 Face to Face Std.: ISO 5752-SERIES 20
 Flanges drilled: PN16 (DN40-DN200)
 PN10 (DN250-DN700)
 Pressure rating: PN16 (DN40-DN200)
 PN10 (DN250-DN700)
 Top Flange: ISO 5211 (DN40-DN700)

VARIATIONS: With handlever
 Various actuators and gearboxes
 DN200-600 available as PN16
 Other dimensions on request.
 Available with GGG body.

EPDM max work temp 110°C (701702/701701)
 Viton max work temp 170°C (702702/702701)

Meson wafer type butterfly valve is multiflanged and suits normally for DIN PN10-16, JIS 5-10K and ANSI-150. Exceptions are DN40-5K and DN600-10K.

No	Part	Material	Code
1	Body	Nodular Cast Iron	GGG40.3
2	Disc	Al Bronze Alloy	-
3	Seat	NBR max work temp 80°C	-
4	Stem	Stainless Steel	SS 431
5	O-Ring	NBR	-
6	Bushing	Brass	-
7	Pin	Duplex 2507	-
8	Key	-	-
9	Cover	Nodular Cast Iron	GGG40.3
10	Bolts and Accessories	Stainless Steel	SS 316

DN	n x ød	Hcd	L	H1	H2	H3	Kg
40	4x18	110	33	73	105	32	2.4
50	4x18	125	43	85	130	32	2.5
65	4x18	145	46	94	140	32	3.2
80	8x18	160	46	105	145	32	3.6
100	8x18	180	52	126	160	32	4.9
125	8x18	210	56	140	170	32	7.0
150	8x22	240	56	151	190	32	7.8
200	12x22	295	60	183	220	40	13.2
250	12x22	350	68	208	260	40	19.2
300	12x22	400	78	252	290	45	32.5
350	16x22	460	78	285	320	45	41.3
400	16x26	515	102	315	356	45	61.0
450	20x26	565	114	380	387	55	79.0
500	20x26	620	127	390	424	55	128.0
600	20x30	725	154	455	524	80	188.0
700	24x30	840	165	530	600	80	-

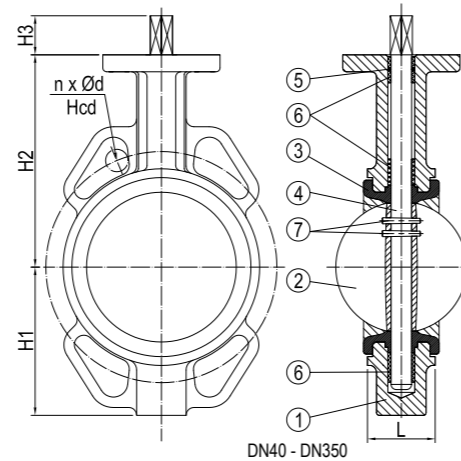
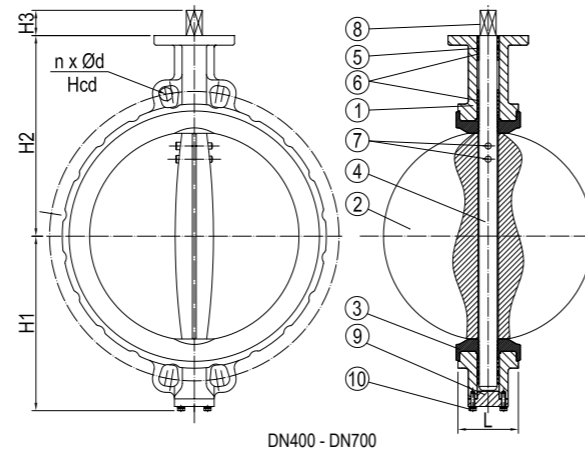
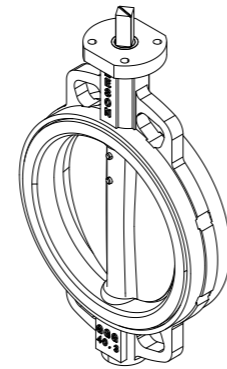

BUTTERFLY VALVE

WAFER TYPE

700772/71
PN16/PN10

DESCRIPTION: Al Bronze body, vulcanized liner wafer type butterfly valve with Al Bronze disc. Centric free stem with standardized pattern for actuator mounting.

APPLICATION: Start/stop of flow: Sea water, water etc.

STANDARD & DESIGN:

Design Code: API 609
 Inspection Std.: API 598
 End Std.: DIN 2501 PN16
 DIN 2501 PN10
 Face to Face Std.: ISO 5752-SERIES 20
 Flanges drilled: PN16 (DN40-DN200)
 PN10 (DN250-DN700)
 Pressure rating: PN16 (DN40-DN200)
 PN10 (DN250-DN700)
 Top Flange: ISO 5211 (DN40-DN700)

VARIATIONS: With handlever
 Various actuators and gearboxes
 DN200-600 available as PN16
 Other dimensions on request.
 Available with GGG body.

EPDM max work temp 110°C (701772/701771)
 Viton max work temp 170°C (702772/702771)

Meson wafer type butterfly valve is multiflanged and suits normally for DIN PN10-16, JIS 5-10K and ANSI-150. Exceptions are DN40-5K and DN600-10K.

No	Part	Material	Code
1	Body	Al Bronze Alloy	-
2	Disc	Al Bronze Alloy	-
3	Seat	NBR max work temp 80°C	-
4	Stem	Stainless Steel	SS 431
5	O-Ring	NBR	-
6	Bushing	Brass	-
7	Pin	Duplex 2507	-
8	Key	-	-
9	Cover	Al Bronze Alloy	-
10	Bolts and Accessories	Stainless Steel	SS 316

DN	n x ød	Hcd	L	H1	H2	H3	Kg
40	4x18	110	33	73	105	32	2.4
50	4x18	125	43	85	130	32	2.5
65	4x18	145	46	94	140	32	3.2
80	8x18	160	46	105	145	32	3.6
100	8x18	180	52	126	160	32	4.9
125	8x18	210	56	140	170	32	7.0
150	8x22	240	56	151	190	32	7.8
200	12x22	295	60	183	220	40	13.2
250	12x22	350	68	208	260	40	19.2
300	12x22	400	78	252	290	45	32.5
350	16x22	460	78	285	320	45	41.3
400	16x26	515	102	315	356	45	61.0
450	20x26	565	114	380	387	55	79.0
500	20x26	620	127	390	424	55	128.0
600	20x30	725	154	455	524	80	188.0
700	24x30	840	165	530	600	80	-

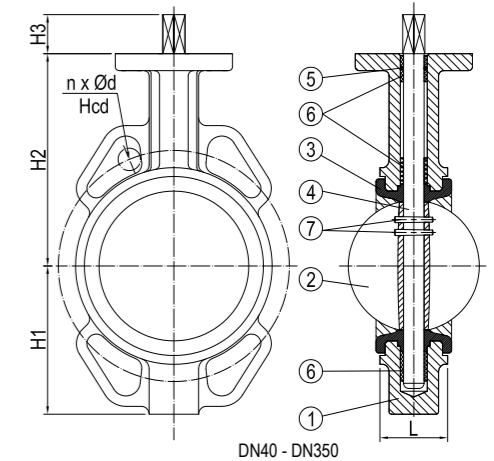
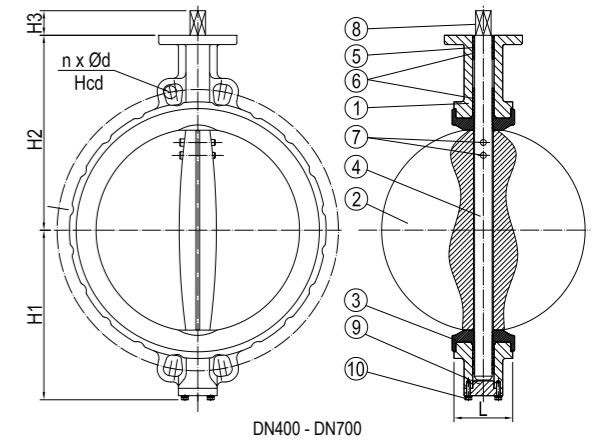
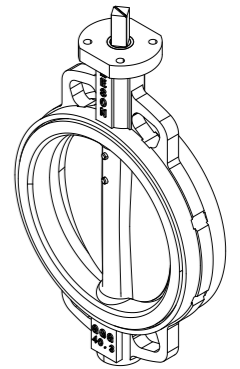



BUTTERFLY VALVE

WAFER TYPE

700902/01
PN16/PN10

DESCRIPTION: Nodular cast iron body, vulcanized liner wafer type butterfly valve with AISI 316 disc. Centric free stem with standardized pattern for actuator mounting.

APPLICATION: Start/stop of flow: Sea water, water, oils and acidic media etc.

STANDARD & DESIGN:

Design Code: API 609
 Inspection Std.: API 598
 End Std.: DIN 2501 PN16
 DIN 2501 PN10
 Face to Face Std.: ISO 5752-SERIES 20
 Flanges drilled: PN16 (DN40-DN200)
 PN10 (DN250-DN700)
 Pressure rating: PN16 (DN40-DN200)
 PN10 (DN250-DN700)
 Top Flange: ISO 5211(DN40-DN700)

VARIATIONS: With handlever
 Various actuators and gearboxes
 DN200-600 available as PN16
 Other dimensions on request.
 Available with GGG body.

EPDM max work temp 110°C (701902/701901)
 Viton max work temp 170°C(702902/702901)

Meson wafer type butterfly valve is multiflanged and suits normally for DIN PN10-16, JIS 5-10K and ANSI-150. Exceptions are DN40-5K and DN600-10K.

No	Part	Material	Code
1	Body	Nodular Cast Iron	GGG40.3
2	Disc	Stainless Steel	SS 316
3	Seat	NBR max work temp 80°C	-
4	Stem	Stainless Steel	SS 431
5	O-Ring	NBR	-
6	Bushing	Brass	-
7	Pin	Duplex 2507	-
8	Key	-	-
9	Cover	Nodular Cast Iron	GGG40.3
10	Bolts and Accessories	Stainless Steel	SS 316

DN	n x ød	Hcd	L	H1	H2	H3	Kg
40	4x18	110	33	73	105	32	2.4
50	4x18	125	43	85	130	32	2.5
65	4x18	145	46	94	140	32	3.2
80	8x18	160	46	105	145	32	3.6
100	8x18	180	52	126	160	32	4.9
125	8x18	210	56	140	170	32	7.0
150	8x22	240	56	151	190	32	7.8
200	12x22	295	60	183	220	40	13.2
250	12x22	350	68	208	260	40	19.2
300	12x22	400	78	252	290	45	32.5
350	16x22	460	78	285	320	45	41.3
400	16x26	515	102	315	356	45	61.0
450	20x26	565	114	380	387	55	79.0
500	20x26	620	127	390	424	55	128.0
600	20x30	725	154	455	524	80	188.0
700	24x30	840	165	530	600	80	-

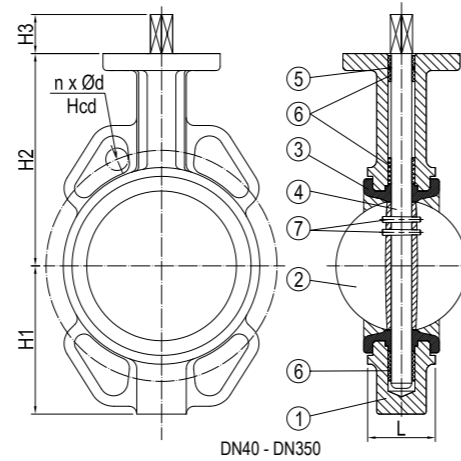
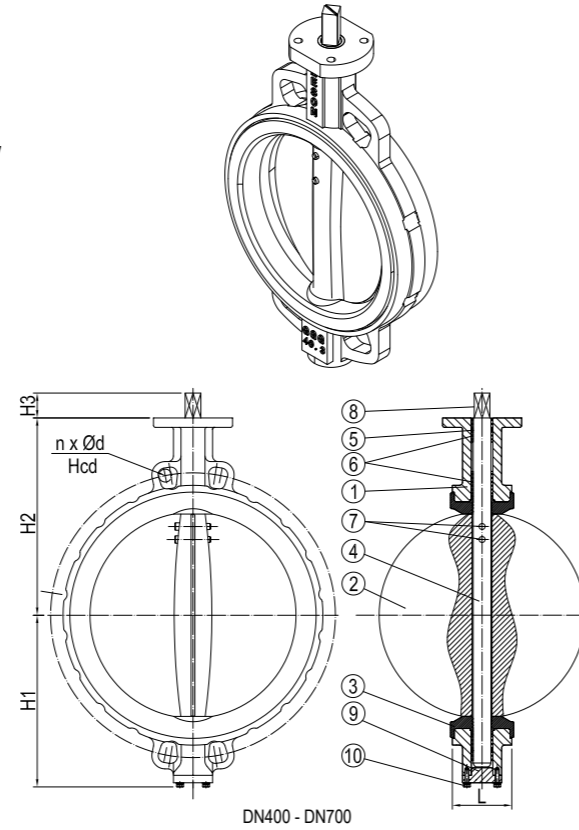

BUTTERFLY VALVE

WAFER TYPE

700703
PN25

DESCRIPTION: Nodular cast iron body, vulcanized NBR liner wafer type butterfly valve with Al Bronze disc. Centric free stem with standardized pattern for actuator mounting.

APPLICATION: Start/stop of flow: Sea water, water etc.

STANDARD & DESIGN:

Design Code: API 609
 Inspection Std.: API 598
 End Std.: DIN 2501 PN25
 Face to Face Std.: ISO 5752-SERIES 20
 Flanges drilled: PN25(DN40-DN300)
 Pressure rating: PN25(DN40-DN300)
 Top Flange: ISO 5211(DN40-DN300)

VARIATIONS: With handlever
 Various actuators and gearboxes
 Other dimensions on request.
 Available with GGG body.

Meson wafer type butterfly valve is multiflanged and suits normally for DIN PN10-16, JIS 5-10K and ANSI-150. Exceptions are DN40-5K and DN600-10K.

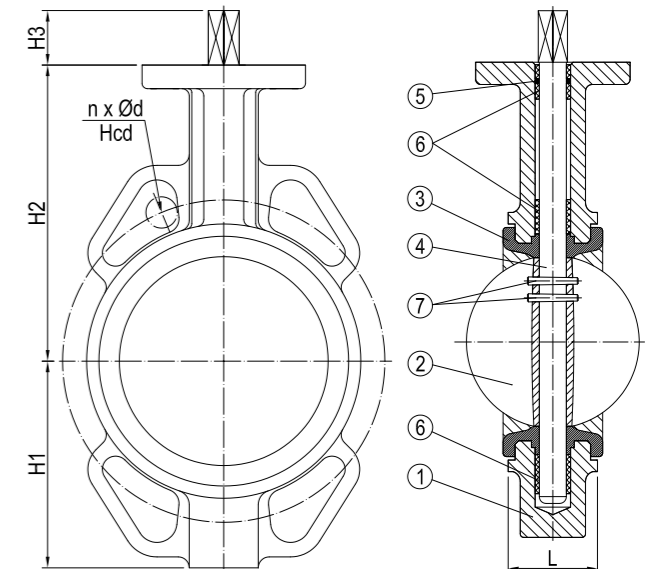
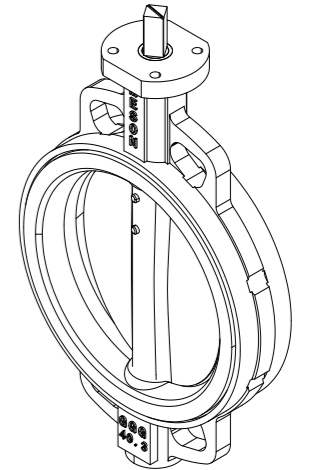

No	Part	Material	Code
1	Body	Nodular Cast Iron	GGG40.3
2	Disc	Al Bronze Alloy	-
3	Seat	NBR max work temp 80°C	-
4	Stem	Stainless Steel	SS 431
5	O-Ring	NBR	-
6	Bushing	Brass	-
7	Pin	Duplex 2507	-

DN	n x ød	Hcd	L	H1	H2	H3	Kg
40	4x18	110	33	73	105	32	2.4
50	4x18	125	43	85	130	32	2.5
65	8x18	145	46	94	140	32	3.2
80	8x18	160	46	105	145	32	3.6
100	8x22	190	52	126	160	32	4.9
125	8x26	220	56	140	170	32	7.0
150	8x26	250	56	151	190	32	7.8
200	12x26	310	60	183	220	40	13.2
250	12x30	370	68	208	260	40	19.2
300	16x30	430	78	252	290	45	32.5



BUTTERFLY VALVE

WAFER TYPE

701903
PN25

DESCRIPTION: Nodular cast iron body, vulcanized EPDM liner wafer type butterfly valve with AISI 316 disc. Centric free stem with standardized pattern for actuator mounting.

APPLICATION: Start/stop of flow: Water, acidic media etc.

STANDARD & DESIGN:

Design Code: API 609
 Inspection Std.: API 598
 End Std.: DIN 2501 PN25
 Face to Face Std.: ISO 5752-SERIES 20
 Flanges drilled: PN25(DN40-DN300)
 Pressure rating: PN25(DN40-DN300)
 Top Flange: ISO 5211(DN40-DN300)

VARIATIONS: With handlever
 Various actuators and gearboxes
 Other dimensions on request.
 Available with GGG body.

Meson wafer type butterfly valve is multiflanged and suits normally for DIN PN10-16, JIS 5-10K and ANSI-150. Exceptions are DN40-5K and DN600-10K.

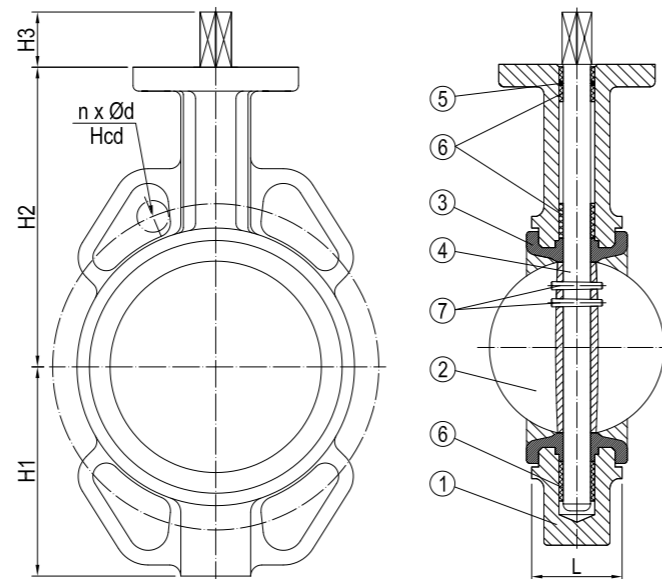
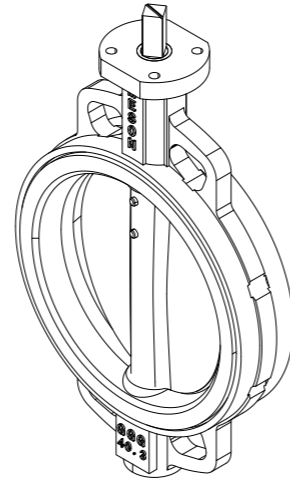

No	Part	Material	Code
1	Body	Nodular Cast Iron	GGG40.3
2	Disc	Stainless Steel	SS 316
3	Seat	EPDM max work temp 110°C	-
4	Stem	Stainless Steel	SS 431
5	O-Ring	NBR	-
6	Bushing	Brass	-
7	Pin	Duplex 2507	-

DN	n x ød	Hcd	L	H1	H2	H3	Kg
40	4x18	110	33	73	105	32	2.4
50	4x18	125	43	85	130	32	2.5
65	8x18	145	46	94	140	32	3.2
80	8x18	160	46	105	145	32	3.6
100	8x22	190	52	126	160	32	4.9
125	8x26	220	56	140	170	32	7.0
150	8x26	250	56	151	190	32	7.8
200	12x26	310	60	183	220	40	13.2
250	12x30	370	68	208	260	40	19.2
300	16x30	430	78	252	290	45	32.5



BUTTERFLY VALVE

LUG TYPE

710702/01
PN16/PN10

DESCRIPTION: Nodular cast iron body, vulcanized liner lugged type butterfly valve with Al Bronze disc. Centric free stem with standardized pattern for actuator mounting.

APPLICATION: Start/stop of flow: Sea water, water etc. Suitable as sea direct.

STANDARD & DESIGN:

Design Code: API 609
 Inspection Std.: API 598
 End Std.: DIN 2501 PN16
 Face to Face Std.: ISO 5752-Series 20
 Flanges drilled: PN16 (DN40-DN150)
 PN10 (DN200-DN700)
 Pressure rating: PN16 (DN40-DN150)
 PN10 (DN200-DN700)
 Top Flange: ISO 5211(DN40-DN700)

VARIATIONS: With handlever
 Various actuators and gearboxes
 DN200-600 available as PN16
 Other dimensions on request.
 Available with GGG body.

EPDM max work temp 110°C (711702/711701)
 Viton max work temp 170°C (712702/712701)

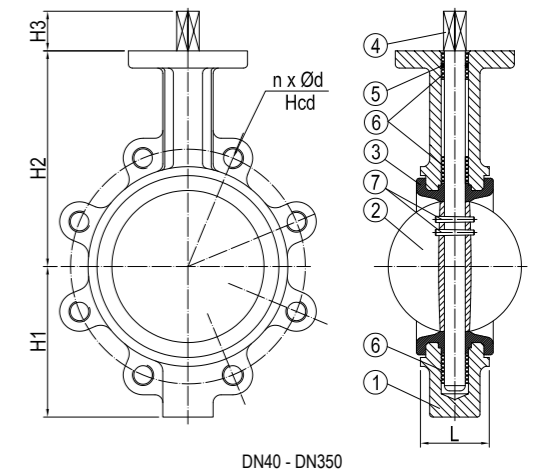
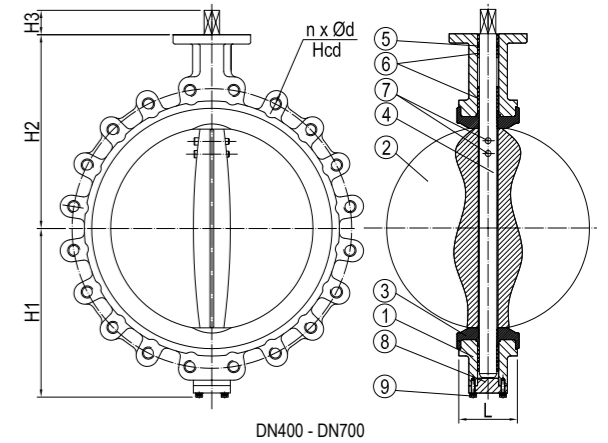
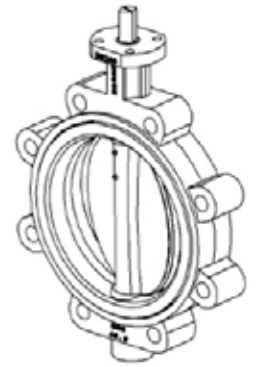

No	Part	Material	Code
1	Body	Nodular Cast Iron	GGG 40.3
2	Disc	Al Bronze Alloy	-
3	Seat	NBR max work temp 80°C	-
4	Stem	Stainless Steel	SS 431
5	O-Ring	NBR	-
6	Bushing	Brass	-
7	Pin	Duplex 2507	-
8	Cover	Nodular Cast Iron	GGG40.3
9	Bolts and Accessories	Stainless Steel	SS 316

DN	n x ød	Hcd	L	H1	H2	H3	Kg
40	4xM16	110	33	73	105	32	3.7
50	4xM16	125	43	85	130	32	3.8
65	4xM16	145	46	94	140	32	4.2
80	8xM16	160	46	105	145	32	4.7
100	8xM16	180	52	126	160	32	9.0
125	8xM16	210	56	140	170	32	10.9
150	8xM20	240	56	151	190	32	14.2
200	8xM20	295	60	183	220	40	18.2
250	12xM20	350	68	208	260	40	26.8
300	12xM20	400	78	252	290	45	40.0
350	16xM20	460	78	285	320	45	56.0
400	16xM24	515	102	315	356	45	96.0
450	20xM24	565	114	380	387	55	122.0
500	20xM24	620	127	390	424	55	202.0
600	20xM27	725	154	455	524	80	270.0
700	24xM27	840	165	530	600	80	-



BUTTERFLY VALVE

LUG TYPE

710772/01
PN16/PN10

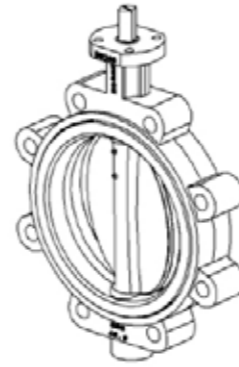

DESCRIPTION: Al Bronze body, vulcanized liner lugged butterfly valve with AlBr disc. Centric free stem with standardized pattern for actuator mounting.

APPLICATION: Start/stop of flow: Sea water, water etc. Suitable as sea direct.

STANDARD & DESIGN:

Design Code: API 609
 Inspection Std.: API 598
 End Std.: DIN 2501 PN16
 Face to Face Std.: ISO 5752-Series 20
 Flanges drilled: PN16 (DN40-DN150)
 PN10 (DN200-DN700)
 Pressure rating: PN16 (DN40-DN150)
 PN10 (DN200-DN700)
 Top Flange: ISO 5211(DN40-DN700)

VARIATIONS:

With handlever
 Various actuators and gearboxes
 DN200-600 available as PN16
 Other dimensions on request.
 Available with GGG body.
 EPDM max work temp 110°C (711772/711771)
 Viton max work temp 170°C (712772/712771)

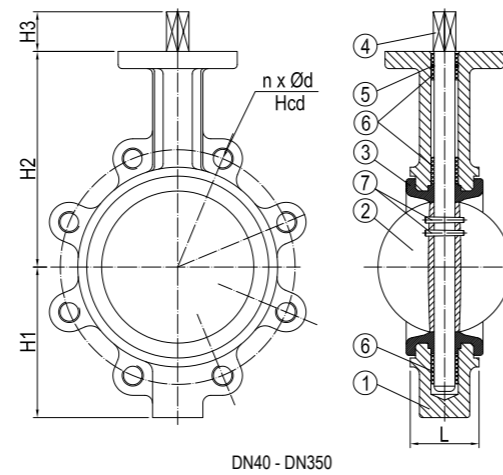
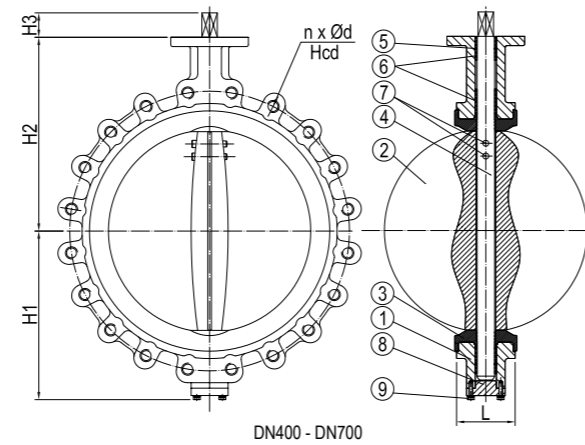

No	Part	Material	Code
1	Body	Al Bronze Alloy	-
2	Disc	Al Bronze Alloy	-
3	Seat	NBR max work temp 80°C	-
4	Stem	Stainless Steel	SS 431
5	O-Ring	NBR	-
6	Bushing	Brass	-
7	Pin	Duplex 2507	-
8	Cover	Al Bronze Alloy	-
9	Bolts and Accessories	Stainless Steel	SS 316

DN	n x ød	Hcd	L	H1	H2	H3	Kg
40	4xM16	110	33	73	105	32	3.7
50	4xM16	125	43	85	130	32	3.8
65	4xM16	145	46	94	140	32	4.2
80	8xM16	160	46	105	145	32	4.7
100	8xM16	180	52	126	160	32	9.0
125	8xM16	210	56	140	170	32	10.9
150	8xM20	240	56	151	190	32	14.2
200	8xM20	295	60	183	220	40	18.2
250	12xM20	350	68	208	260	40	26.8
300	12xM20	400	78	252	290	45	40.0
350	16xM20	460	78	285	320	45	56.0
400	16xM24	515	102	315	356	45	96.0
450	20xM24	565	114	380	387	55	122.0
500	20xM24	620	127	390	424	55	202.0
600	20xM27	725	154	455	524	80	270.0
700	24xM27	840	165	530	600	80	-



BUTTERFLY VALVE

LUG TYPE

710902/01
PN16/PN10

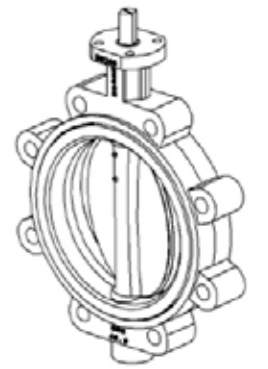

DESCRIPTION: Nodular cast iron body, vulcanized liner lugged type butterfly valve with AISI 316 disc. Centric free stem with standardized pattern for actuator mounting.

APPLICATION: Start/stop of flow: Water, oils and acidic media etc.

STANDARD & DESIGN:

Design Code: API 609
 Inspection Std.: API 598
 End Std.: DIN 2501 PN16
 Face to Face Std.: ISO 5752-Series 20
 Flanges drilled: PN16 (DN40-DN150)
 PN10 (DN200-DN700)
 Pressure rating: PN16 (DN40-DN150)
 PN10 (DN200-DN700)
 Top Flange: ISO 5211(DN40-DN700)

VARIATIONS:

With handlever
 Various actuators and gearboxes
 DN200-600 available as PN16
 Other dimensions on request.
 Available with GGG body.
 EPDM max work temp 110°C (711902/711901)
 Viton max work temp 170°C (712902/712901)

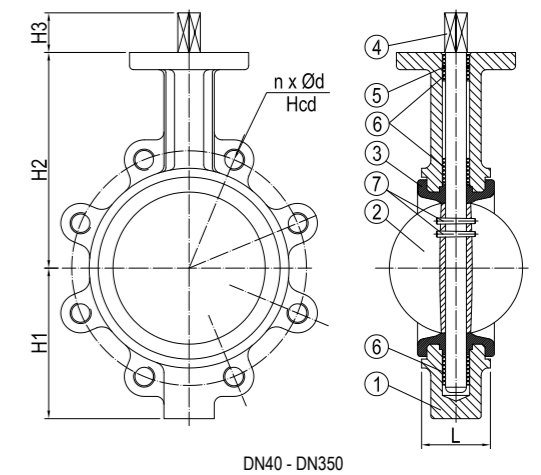
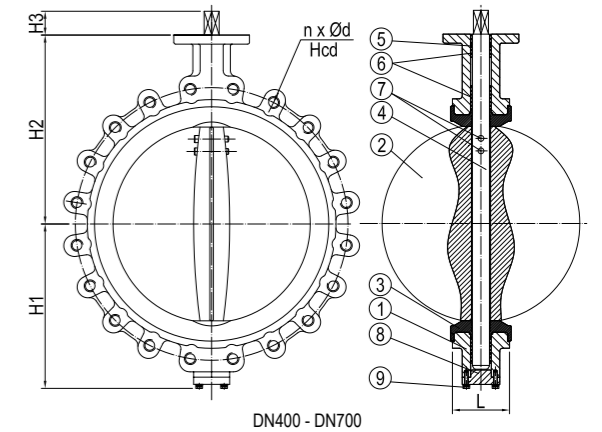

No	Part	Material	Code
1	Body	Nodular Cast Iron	GGG 40.3
2	Disc	Stainless Steel	SS 316
3	Seat	NBR max work temp 80°C	-
4	Stem	Stainless Steel	SS 431
5	O-Ring	NBR	-
6	Bushing	Brass	-
7	Pin	Duplex 2507	-
8	Cover	Nodular Cast Iron	GGG40.3
9	Bolts and Accessories	Stainless Steel	SS 316

DN	n x ød	Hcd	L	H1	H2	H3	Kg
40	4xM16	110	33	73	105	32	3.7
50	4xM16	125	43	85	130	32	3.8
65	4xM16	145	46	94	140	32	4.2
80	8xM16	160	46	105	145	32	4.7
100	8xM16	180	52	126	160	32	9.0
125	8xM16	210	56	140	170	32	10.9
150	8xM20	240	56	151	190	32	14.2
200	8xM20	295	60	183	220	40	18.2
250	12xM20	350	68	208	260	40	26.8
300	12xM20	400	78	252	290	45	40.0
350	16xM20	460	78	285	320	45	56.0
400	16xM24	515	102	315	356	45	96.0
450	20xM24	565	114	380	387	55	122.0
500	20xM24	620	127	390	424	55	202.0
600	20xM27	725	154	455	524	80	270.0
700	24xM27	840	165	530	600	80	-



BUTTERFLY VALVE

LUG TYPE

710703
PN25

DESCRIPTION: Nodular cast iron body, vulcanized NBR liner lugged type butterfly valve with Al Bronze disc. Centric free stem with standardized pattern for actuator mounting.

APPLICATION: Start/stop of flow: Sea water, water etc.

STANDARD & DESIGN:

Design Code: API 609
 Inspection Std.: API 598
 End Std.: DIN 2501 PN25
 Face to Face Std.: ISO 5752-Series 20
 Flanges drilled: PN25(DN40-DN300)
 Pressure rating: PN25(DN40-DN300)
 Top Flange: ISO 5211(DN40-DN300)

VARIATIONS: With handlever
 Various actuators and gearboxes
 Other dimensions on request.
 Available with GGG body.

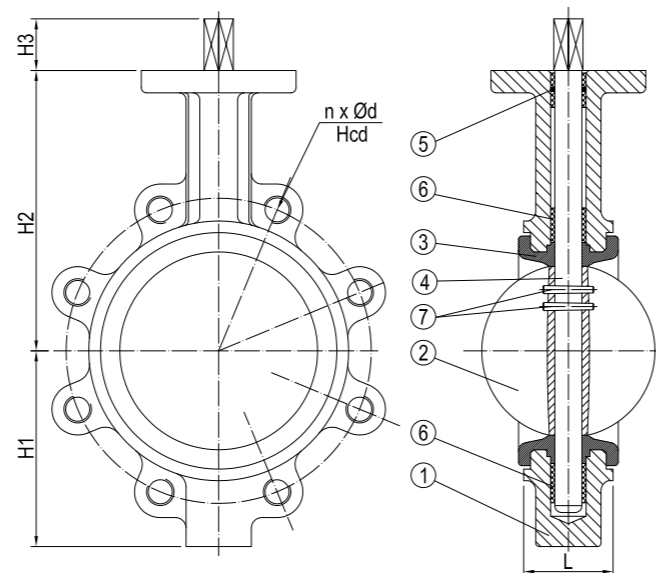
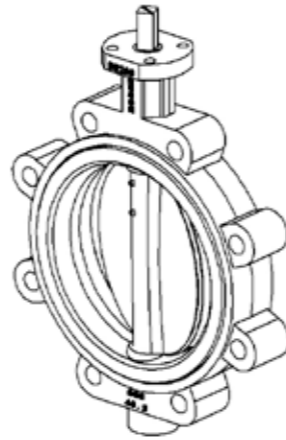

No	Part	Material	Code
1	Body	Nodular Cast Iron	GGG40.3
2	Disc	Al Bronze Alloy	-
3	Seat	NBR max work temp 80°C	-
4	Stem	Stainless Steel	SS 431
5	O-Ring	NBR	-
6	Bushing	Brass	-
7	Pin	Duplex 2507	-

DN	n x ød	Hcd	L	H1	H2	H3	Kg
40	4xM16	110	33	73	105	32	3.7
50	4xM16	125	43	85	130	32	3.8
65	8xM16	145	46	94	140	32	4.2
80	8xM16	160	46	105	145	32	4.7
100	8xM20	190	52	126	160	32	9.0
125	8xM24	220	56	140	170	32	10.9
150	8xM24	250	56	151	190	32	14.2
200	12xM24	310	60	183	220	40	18.2
250	12xM27	370	68	208	260	40	26.8
300	16xM27	430	78	252	290	45	40.0



BUTTERFLY VALVE

LUG TYPE

711903
PN25

DESCRIPTION: Nodular cast iron body, vulcanized EPDM liner lugged type butterfly valve with AISI 316 disc. Centric free stem with standardized pattern for actuator mounting.

APPLICATION: Start/stop of flow: Water, acidic media etc.

STANDARD & DESIGN:

Design Code: API 609
 Inspection Std.: API 598
 End Std.: DIN 2501 PN25
 Face to Face Std.: ISO 5752-Series 20
 Flanges drilled: PN25(DN40-DN300)
 Pressure rating: PN25(DN40-DN300)
 Top Flange: ISO 5211(DN40-DN300)

VARIATIONS: With handlever
 Various actuators and gearboxes
 Other dimensions on request.
 Available with GGG body.

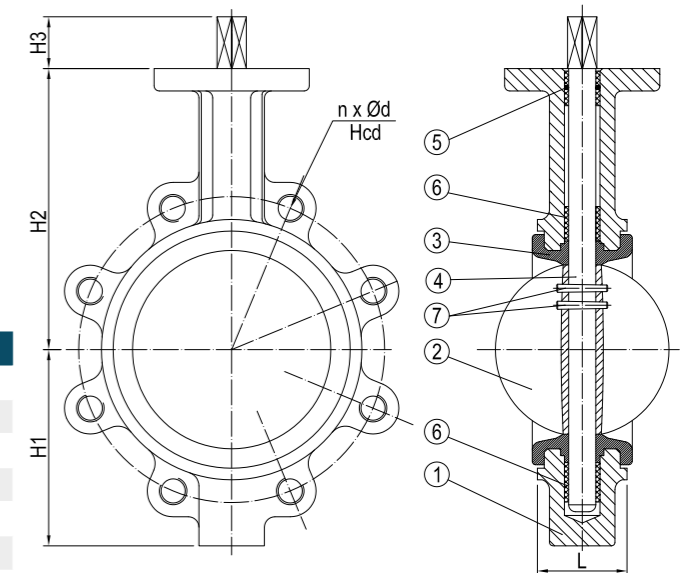
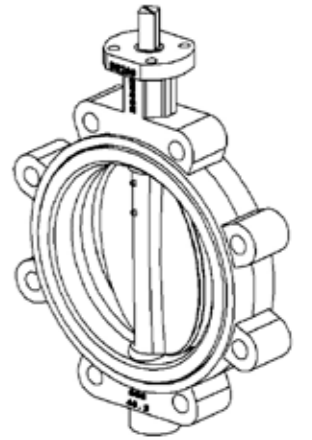

No	Part	Material	Code
1	Body	Nodular Cast Iron	GGG 40.3
2	Disc	Stainless Steel	SS 316
3	Seat	EPDM max work temp 110°C	-
4	Stem	Stainless Steel	SS 431
5	O-Ring	NBR	-
6	Bushing	Brass	-
7	Pin	Duplex 2507	-

DN	n x ød	Hcd	L	H1	H2	H3	Kg
40	4xM16	110	33	73	105	32	3.7
50	4xM16	125	43	85	130	32	3.8
65	8xM16	145	46	94	140	32	4.2
80	8xM16	160	46	105	145	32	4.7
100	8xM20	190	52	126	160	32	9.0
125	8xM24	220	56	140	170	32	10.9
150	8xM24	250	56	151	190	32	14.2
200	12xM24	310	60	183	220	40	18.2
250	12xM27	370	68	208	260	40	26.8
300	16xM27	430	78	252	290	45	40.0



BUTTERFLY VALVE

FLANGED ENDS

780702/01
PN16/PN10

DESCRIPTION: Nodular cast iron body, vulcanized liner double flanged butterfly valve with Al Bronze disc. Centric free stem with standardized pattern for actuator mounting.

APPLICATION: Start/stop of flow: Sea water, water etc. Suitable as sea direct.

STANDARD & DESIGN:

Design Code: API 609
 Inspection Std.: API 598
 End Std.: DIN EN 1092-2 PN16
 DIN EN 1092-2 PN10
 Face to Face Std.: ISO 5752-Series 13
 Flanges drilled: PN16 (DN50-DN150)
 PN10 (DN200-DN600)
 Pressure rating: PN16 (DN50-DN150)
 PN10 (DN200-DN600)
 Top Flange: ISO 5211(DN50-DN600)

VARIATIONS: With handlever.
 Various actuators and gearboxes.
 Other dimensions on request.
 Available with GGG body.
 EPDM max work temp 110°C (781702/781701)

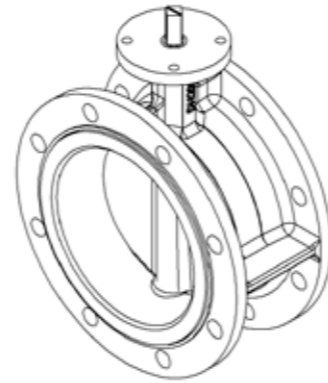

No	Part	Material	Code
1	Body	Nodular Cast Iron	GGG40.3
2	Disc	Al Bronze alloy	-
3	Seat	NBR max work temp 80°C	-
4	Stem	Stainless Steel	SS 431
5	O-Ring	NBR	-
6	Bushing	Brass	-
7	Pin	Duplex	-

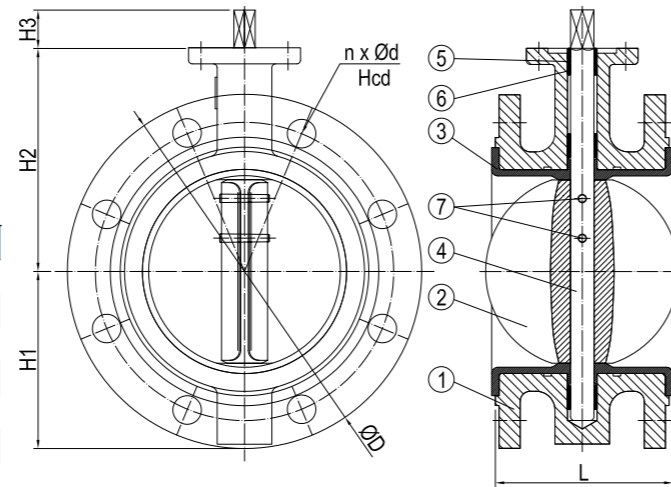

DN	n x ød	Hcd	øD	L	H1	H2	H3	Kg
50	4x18	125	165	108	68	126	32	8
65	4x18	145	185	112	74	134	32	9
80	8x18	160	200	114	82	146	32	11
100	8x18	180	220	127	95	158	32	13
125	8x18	210	250	140	113	180	32	17
150	8x22	240	285	140	130	200	32	23
200	8x22	295	340	152	155	220	40	32
250	12x22	350	395	165	190	255	40	50
300	12x22	400	445	178	213	300	45	65
350	16x22	460	505	190	245	342	45	95
400	16x26	515	565	216	290	375	45	130
450	20x26	565	615	222	320	414	55	150
500	20x26	620	670	229	345	430	55	200
600	20x30	725	780	267	400	500	80	300



BUTTERFLY VALVE

FLANGED ENDS

740702/01
PN16/PN10

DESCRIPTION: Nodular cast iron body, back seated double flanged butterfly valve with Al Bronze disc. Centric free stem with standardized pattern for actuator mounting. F4 short type.

APPLICATION: Start/stop of flow: Sea water, water etc. Suitable as sea direct.

STANDARD & DESIGN:

Design Code: -
 Inspection Std.: -
 End Std.: DIN 2501
 Face to Face Std.: ISO 5752 SERIES 14
 Flanges drilled: PN16 (DN40-DN150)
 PN10 (DN200-DN600)
 Pressure rating: PN16 (DN40-DN150)
 PN10 (DN200-DN600)
 Top Flange: ISO 5211 (DN40-DN600)

VARIATIONS: With handlever
 Various actuators and gearboxes
 Other dimensions on request.
 EPDM max work temp 110°C (741702/741701)

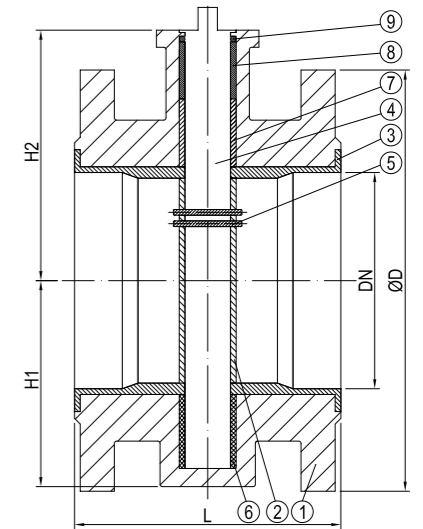
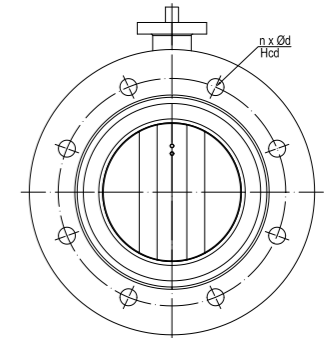
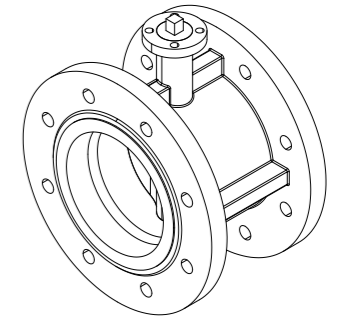

No	Part	Material	Code
1	Body	Nodular Cast Iron	GGG40
2	Disc	Al-Bronze alloy	C954
3	Seat	NBR max work temp 80°C	-
4	Stem	Stainless Steel	ASTM SS431
5	Taper Pins	Stainless Steel	ASTM A276 304
6	Middle Bushing	PTFE	-
7	Long Bushing	PTFE	-
8	Short Bushing	PTFE	-
9	O-Ring	NBR	-

DN	n x ød	Hcd	øD	L	H1	H2	Kg
40	4x18	110	150	140	83	130	11
50	4x18	125	165	150	83	130	13
65	4x18	145	185	170	95	140	15
80	8x18	160	200	180	102	145	18
100	8x18	180	220	190	124	160	20
125	8x18	210	250	200	137	170	28
150	8x22	240	285	210	148	190	30
200	8x22	295	340	230	181	220	41
250	12x22	350	395	250	210	260	74
300	12x22	400	445	270	248	290	86
350	16x22	460	505	290	254	310	106
400	16x26	515	565	310	282	340	120
450	20x26	565	615	330	320	375	150
500	20x26	620	670	350	348	430	220
600	20x30	725	780	390	390	500	308



BUTTERFLY VALVE

WAFER TYPE

762962
PN16

DESCRIPTION: Cast steel body, high performance wafer type butterfly valve with stainless steel disc with PTFE sealing. Double offset free stem with standardized pattern for actuator mounting.

APPLICATION: Start/stop and throttling: Oils, wide range chemicals etc. Used as e.g. cargo valve

STANDARD & DESIGN:

Design Code:	EN 593
Inspection Std.:	EN 12266-1
End Std.:	EN 1092-1
Face to Face Std.:	EN 558
Flanges drilled:	PN16 (DN50-DN600)
Top Flange:	ISO 5211 (DN50-DN600)
Pressure rating:	PN16 (DN50-DN600)

VARIATIONS: Metal to metal seat. Metal + PTFE seat as fire safe. Various actuators and gearboxes. Other dimensions and materials on request.

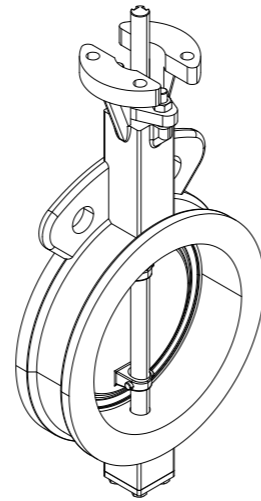

No	Part	Material	Code
1	Body	Cast Steel	A216 WCB
2	Disc	Stainless Steel	A351 CF8
3	Seat	PTFE	-
4	Retainer	Stainless Steel	SUS 304
5	Stem	Stainless Steel	SUS 304
6	Taper Pin	Stainless Steel	SUS 304
7	Upper Bush	316 SS+Graphite	-
8	Lower Bush	316 SS+Graphite	-
9	Gland Ring	Stainless Steel	SUS 304
10	Packing	PTFE	-
11	Gland Flange	Stainless Steel	SUS 304
12	Stud Bolt/SW	Stainless Steel	SUS 304
13	Hex Nut	Stainless Steel	SUS 304
14	Gasket	PTFE	-
15	End Cover	Stainless Steel	SUS 304
16	Hex Bolt/SW	Stainless Steel	SUS 304
17	Wrench Bolt	Stainless Steel	SUS 304

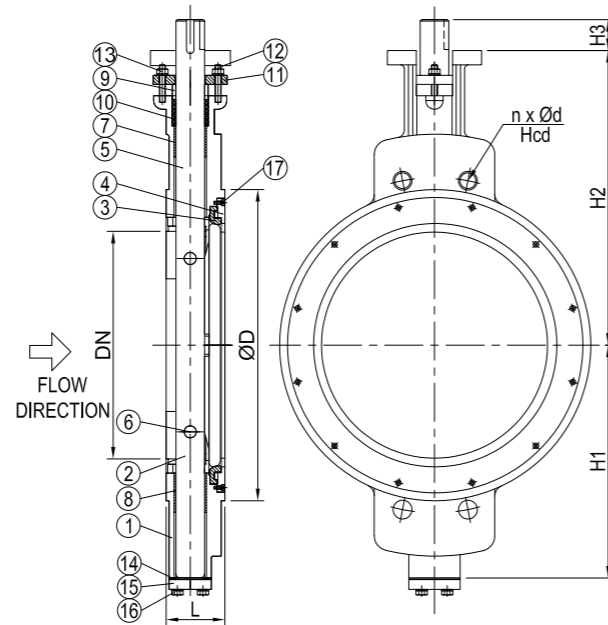

DN	n x ød	Hcd	øD	L	H1	H2	H3	Kg
50	2x18	125	97	43	70	142.5	41	3.1
65	2x18	145	108	46	76	150	41	4.3
80	2x18	160	130	46	82	190	41	4.9
100	2x18	180	155	52	93	200.9	41	6.3
125	2x18	210	180	56	109	219.9	41	8.7
150	2x22	240	205	56	133	243.9	41	10.2
200	2x22	295	256	60	160	269	41	19.9
250	2x26	355	321	70	190.5	314	41	32.2
300	4x26	410	372	78	275	355	41	43.5
350	4x26	470	413	78	309	391	41	63.3
400	4xM27	525	469	102	336	438	55	91.9
450	4xM27	585	534	114	370	470	55	125.6
500	4xM30	650	584	127	397.5	504	55	171.2
600	4xM33	770	692	154	452.5	575	55	268.4



BUTTERFLY VALVE

WAFER TYPE

762992
PN16

DESCRIPTION: AISI 316 equivalent body and disc, high performance wafer type butterfly valve with PTFE sealing. Double offset free stem with standardized pattern for actuator mounting.

APPLICATION: Start/stop and throttling: Water, oils, wide range chemicals etc. Used as e.g. cargo valve

STANDARD & DESIGN:

Design Code:	EN 593
Inspection Std.:	EN 12266-1
End Std.:	EN 1092-1
Face to Face Std.:	EN 558
Flanges drilled:	PN16 (DN50-DN600)
Top Flange:	ISO 5211 (DN50-DN600)
Pressure rating:	PN16 (DN50-DN600)

VARIATIONS: Metal to metal seat. Metal + PTFE seat as fire safe. Various actuators and gearboxes. Other dimensions and materials on request.

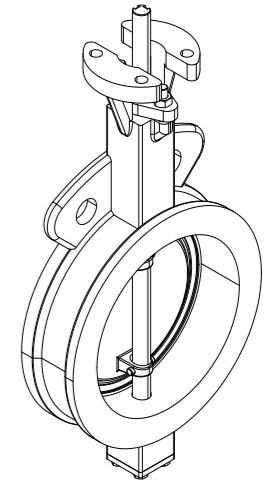

No	Part	Material	Code
1	Body	Stainless Steel	CF8M
2	Disc	Stainless Steel	CF8M
3	Seat	PTFE	-
4	Retainer	Stainless Steel	SUS 316L
5	Stem	Stainless Steel	SUS 316L
6	Taper Pin	Stainless Steel	SUS 316L
7	Upper Bush	316 SS+Graphite	-
8	Lower Bush	316 SS+Graphite	-
9	Gland Ring	Stainless Steel	SUS 304
10	Packing	PTFE	-
11	Gland Flange	Stainless Steel	SUS 304
12	Stud Bolt/SW	Stainless Steel	SUS 304
13	Hex Nut	Stainless Steel	SUS 304
14	Gasket	PTFE	-
15	End Cover	Stainless Steel	SUS 304
16	Hex Bolt/SW	Stainless Steel	SUS 304
17	Wrench Bolt	Stainless Steel	SUS 304

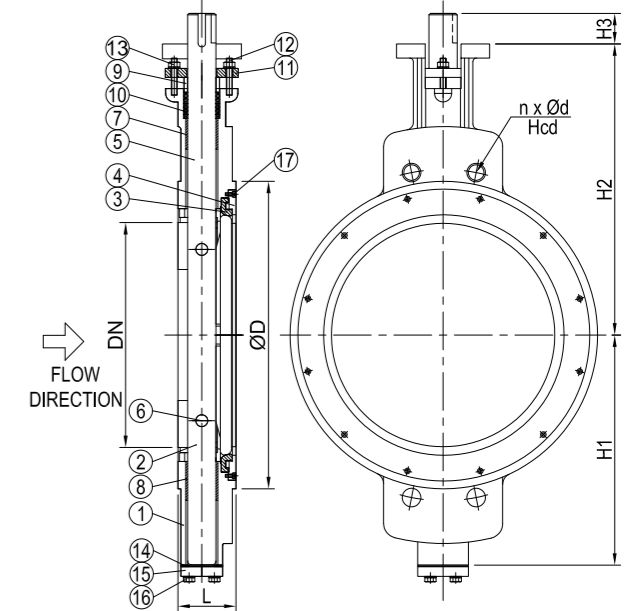

DN	n x ød	Hcd	øD	L	H1	H2	H3	Kg
50	2x18	125	97	43	70	142.5	41	3.2
65	2x18	145	108	46	76	150	41	4.4
80	2x18	160	130	46	82	190	41	5.0
100	2x18	180	155	52	93	200.9	41	6.5
125	2x18	210	180	56	109	219.9	41	8.9
150	2x22	240	205	56	133	243.9	41	10.4
200	2x22	295	256	60	160	269	41	20.2
250	2x26	355	321	70	190.5	314	41	32.7
300	4x26	410	372	78	275	355	41	44.3
350	4x26	470	413	78	309	391	41	64.3
400	4xM27	525	469	102	336	438	55	93.5
450	4xM27	585	534	114	370	470	55	127.6
500	4xM30	650	584	127	397.5	504	55	173.5
600	4xM33	770	692	154	452.5	575	55	271.8



BUTTERFLY VALVE

LUG TYPE

772962
PN 16

DESCRIPTION: Cast steel body, high performance lugged type butterfly valve with stainless steel disc with PTFE sealing. Double offset free stem with standardized pattern for actuator mounting.

APPLICATION: Start/stop and throttling: Water, oils, wide range chemicals etc. Used as e.g. cargo valve.

STANDARD & DESIGN:

Design Code:	EN 593
Inspection Std.:	EN 12266-1
End Std.:	EN 1092-1
Face to Face Std.:	EN 558
Flanges drilled:	PN16 (DN50-DN600)
Top Flange:	ISO 5211 (DN50-DN600)
Pressure rating:	PN16 (DN50-DN600)

VARIATIONS: Metal to metal seat.

Metal + PTFE seat as fire safe.

Various actuators and gearboxes.

Other dimensions and materials on request.

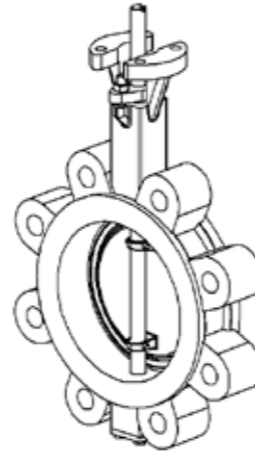

No	Part	Material	Code
1	Body	Cast Steel	A216 WCB
2	Disc	Stainless Steel	A351 CF8
3	Seat	PTFE	-
4	Retainer	Stainless Steel	SUS 304
5	Stem	Stainless Steel	SUS 304
6	Taper Pin	Stainless Steel	SUS 304
7	Upper Bush	316 SS+Graphite	-
8	Lower Bush	316 SS+Graphite	-
9	Gland Ring	Stainless Steel	SUS 304
10	Packing	PTFE	-
11	Gland Flange	Stainless Steel	SUS 304
12	Stud Bolt/SW	Stainless Steel	SUS 304
13	Hex Nut	Stainless Steel	SUS 304
14	Gasket	PTFE	-
15	End Cover	Stainless Steel	SUS 304
16	Hex Bolt/SW	Stainless Steel	SUS 304
17	Wrench Bolt	Stainless Steel	SUS 304

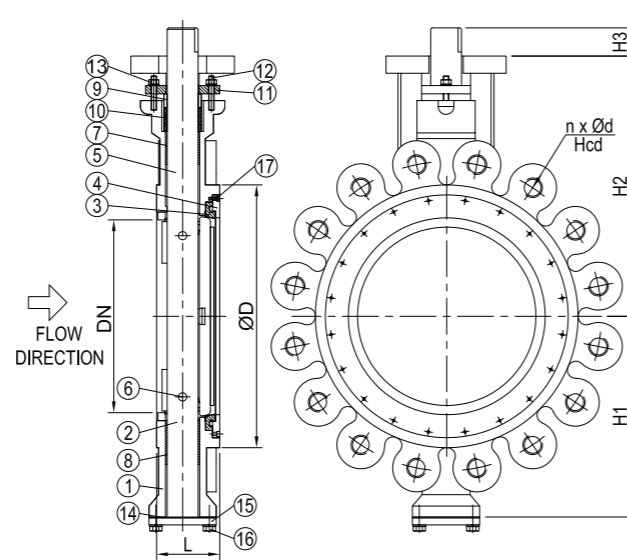

DN	n x ød	Hcd	øD	L	H1	H2	H3	Kg
50	4xM16	125	100	43	70	142.5	41	5.4
65	4xM16	145	108	46	76	150	41	7.2
80	8xM16	160	121	46	99	168.5	41	8.9
100	8xM16	180	155	52	110	180	41	10.8
125	8xM16	210	180	56	135	193	41	13.4
150	8xM20	240	205	56	140	195	41	17.1
200	12xM20	295	266	60	176	240	41	28.0
250	12xM24	355	321	70	215	302	41	42.7
300	12xM24	410	367	78	240	325	41	56.2
350	16xM24	470	430	78	263	350	41	87.5
400	16xM27	525	470	102	292	412	55	118.1
450	20xM27	585	534	114	320	440	55	161.4
500	20xM30	650	610	127	370	505	55	211.7
600	20xM33	770	692	154	410	530	55	332.6



BUTTERFLY VALVE

LUG TYPE

772992
PN 16

DESCRIPTION: AISI 316 equivalent body and disc, high performance lugged type butterfly valve with PTFE sealing. Double offset free stem with standardized pattern for actuator mounting.

APPLICATION: Start/stop and throttling: Water, oils, wide range chemicals etc. Used as e.g. cargo valve.

STANDARD & DESIGN:

Design Code:	EN 593t
Inspection Std.:	EN 12266-1
End Std.:	EN 1092-1
Face to Face Std.:	EN 558
Flanges drilled:	PN16 (DN50-DN600)
Top Flange:	ISO 5211 (DN50-DN600)
Pressure rating:	PN16 (DN50-DN600)

VARIATIONS: Metal to metal seat.

Metal + PTFE seat as fire safe.

Various actuators and gearboxes.

Other dimensions and materials on request.

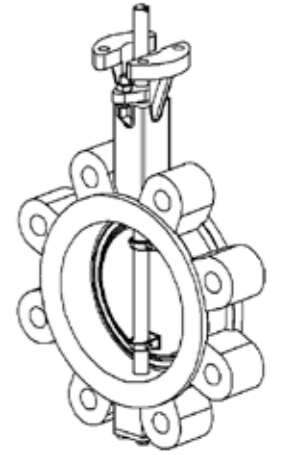

No	Part	Material	Code
1	Body	Stainless Steel	CF8M
2	Disc	Stainless Steel	CF8M
3	Seat	PTFE	-
4	Retainer	Stainless Steel	SUS 316L
5	Stem	Stainless Steel	SUS 316L
6	Taper Pin	Stainless Steel	SUS 316L
7	Upper Bush	316 SS+Graphite	-
8	Lower Bush	316 SS+Graphite	-
9	Gland Ring	Stainless Steel	SUS 304
10	Packing	PTFE	-
11	Gland Flange	Stainless Steel	SUS 304
12	Stud Bolt/SW	Stainless Steel	SUS 304
13	Hex Nut	Stainless Steel	SUS 304
14	Gasket	PTFE	-
15	End Cover	Stainless Steel	SUS 304
16	Hex Bolt/SW	Stainless Steel	SUS 304
17	Wrench Bolt	Stainless Steel	SUS 304

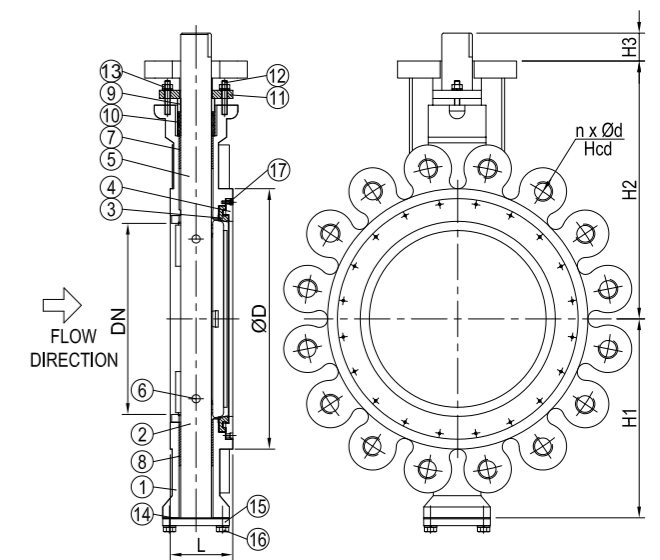

DN	n x ød	Hcd	øD	L	H1	H2	H3	Kg
50	4xM16	125	100	43	70	142.5	41	5.5
65	4xM16	145	108	46	76	150	41	7.3
80	8xM16	160	121	46	99	168.5	41	9.1
100	8xM16	180	155	52	110	180	41	11.1
125	8xM16	210	180	56	135	193	41	13.7
150	8xM20	240	205	56	140	195	41	17.5
200	12xM20	295	266	60	176	240	41	28.5
250	12xM24	355	321	70	215	302	41	43.5
300	12xM24	410	367	78	240	325	41	57.2
350	16xM24	470	430	78	263	350	41	89.2
400	16xM27	525	470	102	292	412	55	120.8
450	20xM27	585	534	114	320	440	55	164.9
500	20xM30	650	610	127	370	505	55	215.8
600	20xM33	770	692	154	410	530	55	339.0



BUTTERFLY VALVE

FLANGED ENDS

782992
PN 16

DESCRIPTION: AISI 316 equivalent body and disc, high performance double flanged type butterfly valve with PTFE sealing. Double offset free stem with standardized pattern for actuator mounting.

APPLICATION: Start/stop and throttling: Water, oils, wide range chemicals etc. Used as e.g. cargo valve.

STANDARD & DESIGN:

Design Code: EN 593
 Inspection Std.: EN 12266-1
 End Std.: EN 1092-1
 Face to Face Std.: EN 558
 Flanges drilled: PN16 (DN50-DN600)
 Top Flange: ISO 5211 (DN50-DN600)
 Pressure rating: PN16 (DN50-DN600)

VARIATIONS: Metal to metal seat.

Metal + PTFE seat as fire safe.

Various actuators and gearboxes.

Other dimensions and materials on request.

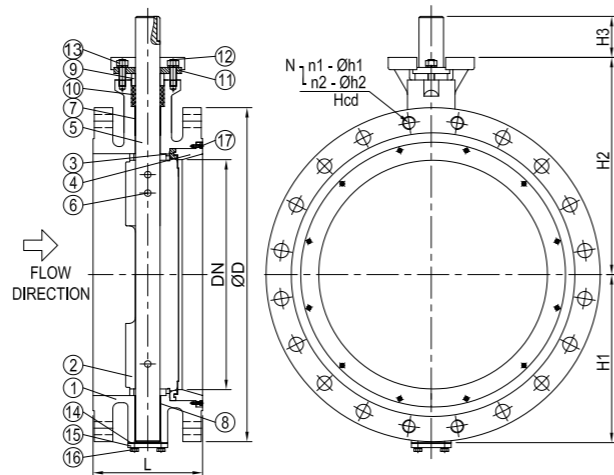
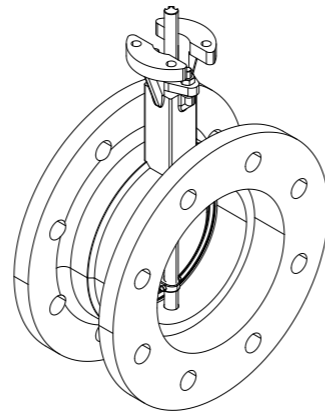

No	Part	Material	Code
1	Body	Stainless Steel	CF8M
2	Disc	Stainless Steel	CF8M
3	Seat	PTFE	-
4	Retainer	Stainless Steel	SUS 316L
5	Stem	Stainless Steel	SUS 316L
6	Taper Pin	Stainless Steel	SUS 316L
7	Upper Bush	316 SS+Graphite	-
8	Lower Bush	316 SS+Graphite	-
9	Gland Ring	Stainless Steel	SUS 316L
10	Packing	PTFE	-
11	Gland Flange	Stainless Steel	SUS 304
12	Stud Bolt/SW	Stainless Steel	SUS 304
13	Hex Nut	Stainless Steel	SUS 304
14	Gasket	PTFE	-
15	End Cover	Stainless Steel	SUS 316L
16	Hex Bolt/SW	Stainless Steel	SUS 304
17	Wrench Bolt	Stainless Steel	SUS 304

DN	N	n1	øh1	n2	øh2	Hcd	øD	L	H1	H2	H3	Kg
50	4	-	-	-	18	125	167	108	88.5	152	41	9.0
65	4	-	-	-	18	145	185	112	97.5	164.5	41	10.9
80	8	4	M16	4	18	160	200	114	105	172	41	13.4
100	8	4	M16	4	18	180	227	127	118.5	185	41	17.1
125	8	4	M16	4	18	210	257	140	134	210.5	41	20.6
150	8	4	M20	4	22	240	305	140	157	222	41	25.8
200	12	4	M20	8	22	295	360	152	185	260	41	38.3
250	12	4	M24	8	26	355	406	165	218	299	41	61.0
300	12	4	M24	8	26	410	455	178	240	320	41	78.7
350	16	4	M24	12	26	470	538	190	290	365	41	123.3
400	16	4	M27	12	33	525	600	216	325	400	55	180.9
450	20	4	M27	16	33	585	635	222	342.5	417.5	55	245.6
500	20	4	M30	16	33	650	730	229	375	504	55	319.1
600	20	4	M33	16	36	770	815	267	410	540	55	502.3



HAND LEVER

7H0000

DESCRIPTION: Manual hand lever, with open/close indicator. For mounting on centric butterfly valves.

APPLICATION: For mounting on butterfly valves in non exposed environment.

STANDARD & DESIGN:

Design Code: -
 Inspection Std.: -
 End Std.: -
 Face to Face Std.: -
 Flanges drilled: -
 Pressure rating: -

VARIATIONS: Other materials on request.

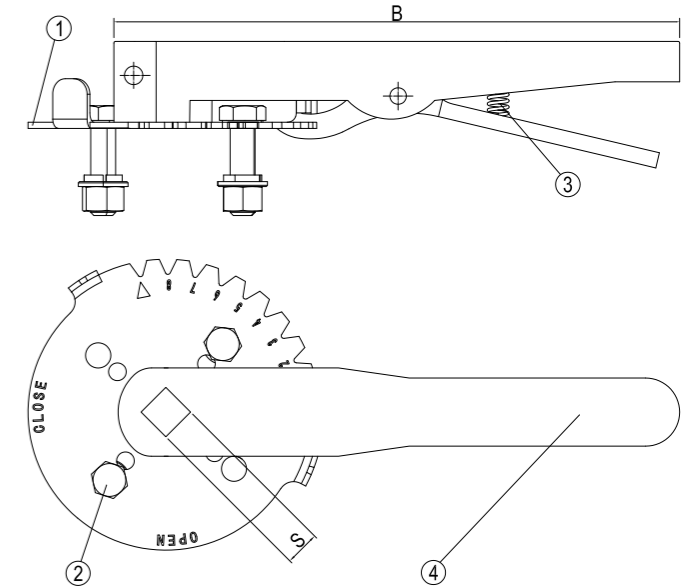
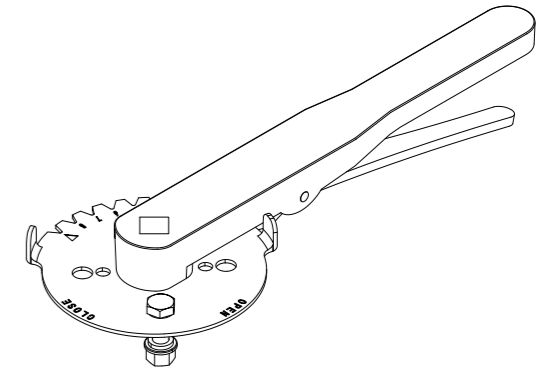

No	Part	Material	Code
1	Indicator Plate	Steel	Q235
2	Screws	Stainless Steel	SS 316
3	Spring	Stainless Steel	SS 316
4	Lever	Malleable Iron	-

DN	S	B	Kg
40	9	223	0.9
50	9	223	0.9
65	11	223	0.9
80	14	223	0.9
100	14	223	0.9
125	14	223	0.9
150	17	223	0.9
200	17	358	2.3
250	22	358	2.3
300	22	503	-



GEARBOX

7V0000

DESCRIPTION: Manual hand wheel gearbox, with open/close indicator, for mounting on centric butterfly valves. With horizontally fitted hand wheel shaft.

APPLICATION: For mounting on butterfly valves in non exposed environment.

STANDARD & DESIGN:

- Design Code: -
- Inspection Std.: -
- End Std.: -
- Face to Face Std.: -
- Flanges drilled: -
- Pressure rating: -

VARIATIONS: Water tight type available.

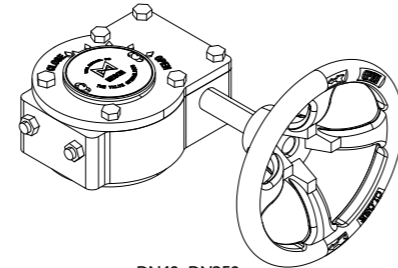

DN40 - DN350

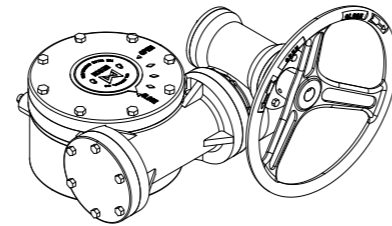

DN400 - DN700

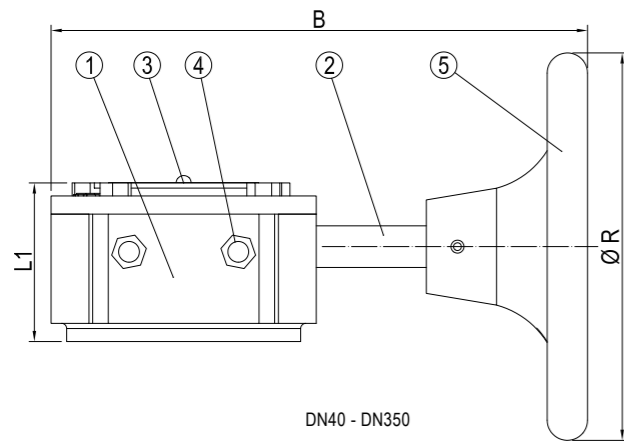

DN40 - DN350

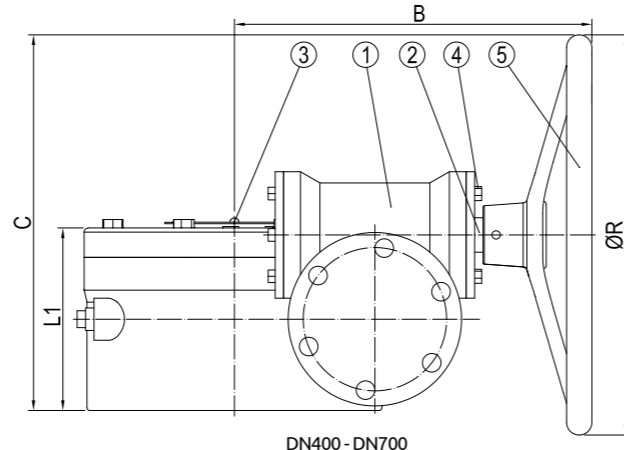

DN400 - DN700

No	Part	Material	Code
1	Body	Cast Iron	-
2	Shaft	Stainless Steel	SS 316
3	Indicator	Stainless Steel	SS 316
4	Bolts and Nuts	Stainless Steel	SS 316
5	Handwheel	Cast Iron	-

DN	L1	C	B	øR	Kg
40	65	-	154	135	4
50	65	-	154	135	4
65	65	-	154	135	4
80	65	-	154	135	4
100	65	-	154	135	4
125	65	-	154	135	4
150	65	-	154	135	4
200	77	-	225	285	9
250	77	-	225	285	9
300	80	-	215	285	10
350	80	-	215	285	10
400	121	271	256	285	22
450	121	271	256	285	22
500	121	271	256	285	36
600	130	330	285	385	52
700	-	378	337	425	87.5



BUTTERFLY TOPFLANGE DIMENSIONS

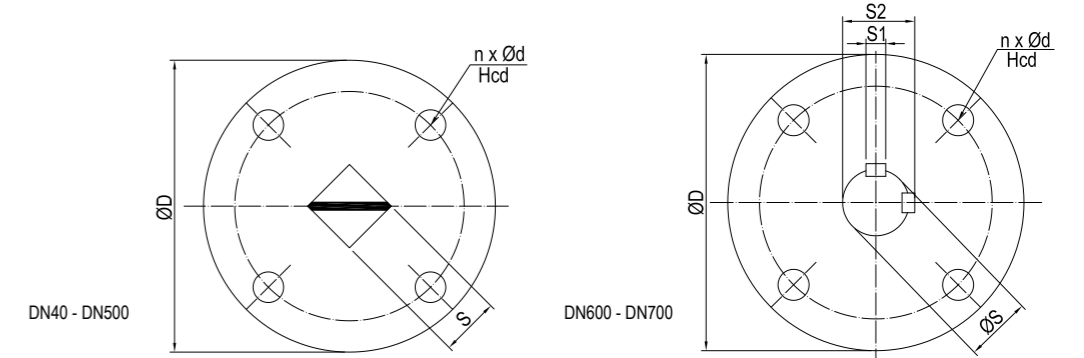

DN	n x ød	Hcd	øD	S	S1	S2	øS
40	4x7	50	90	9	-	-	-
50	4x7	50	90	9	-	-	-
65	4x7	50	90	11	-	-	-
80	4x9	70	90	14	-	-	-
100	4x9	70	90	14	-	-	-
125	4x9	70	90	14	-	-	-
150	4x9	70	90	17	-	-	-
200	4x9	70	90	17	-	-	-
250	4x11	102	125	22	-	-	-
300	4x11	102	125	22	-	-	-
350	4x17.5	140	175	27	-	-	-
400	4x17.5	140	175	27	-	-	-
450	4x22	165	210	36	-	-	-
500	4x22	165	210	36	-	-	-
600	4x22	165	210	-	14	54	50
700	8x18	254	300	-	18	67.35	63.35

These dimensions are valid for 700702/701702/702702, 700772/701772/702772, 700902/701902/702902, 701903, 700703, 710702/711702/712702, 710772/711772/712772, 710902/711902/712902, 711903, 710703, 780702/781702.

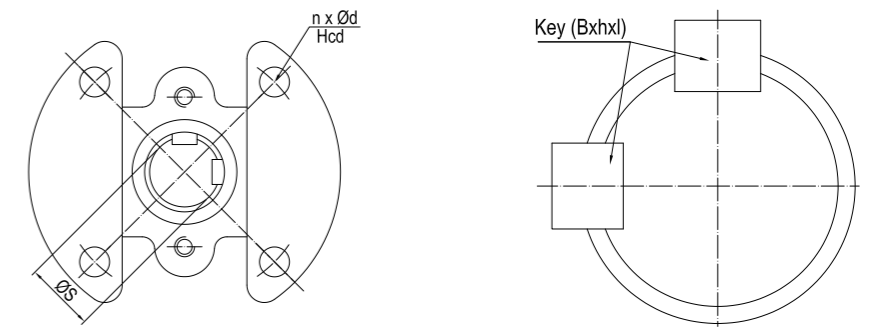

DN	n x ød	Hcd	øS	B	h	l
50	4x10	70	14	5	5	35
65	4x10	70	14	5	5	35
80	4x10	70	14	5	5	35
100	4x10	70	14	5	5	35
125	4x10	70	18	6	6	35
150	4x10	70	20	6	6	35
200	4x12	102	28	8	7	35
250	4x12	102	32	10	8	35
300	4x14	125	32	10	8	35
350	4x18	140	32	10	8	35
400	4x18	140	40	12	8	50
450	4x22	165	45	14	9	50
500	4x22	165	50	14	9	50
600	4x22	165	60	18	11	50

These dimensions are valid for 762962, 762992, 772962, 772992, 782992.



MUD BOXES & STRAINERS

For filtration of dirt or particles in a diversified range of fluids. Straight, angle and Y-patterns.
Available with flanged or threaded connections.
Available with screen perforation in different mesh sizes.
Tailor made galvanized filters according to customer specification also available.



MUD BOX

STRAIGHT TYPE, FLANGED ENDS

482021
PN4/PN2.5

DESCRIPTION: Straight type, Rg5 body and bonnet mud box with AISI 316 strainer basket. Fitted with drain plug and bonnet lifting lug. Raised face flanged.

APPLICATION: Typically used as sea water suction and bilge suction filter etc. Suction and discharge lines for sea cooling water and bilge systems.

STANDARD & DESIGN:

Design Code: DIN 87151 D - with drain plug.
 Inspection Std.: -
 End Std.: EN 1092-3/B (DIN 2501)
 Face to Face Std.: DIN 87151 - straight type.
 Flanges drilled: PN 10 (DN40-DN700)
 Pressure rating: PN 4 (DN25-DN450)
 PN 2.5 (DN500-DN700)
 Temperature range: -10°C to +120°C
 Mesh size: 5mm (DN25-DN65)
 8mm (DN80-DN700)

VARIATIONS: CuNiFe strainer basket

Other mesh sizes
 Bonnet air vent
 Other materials on request.

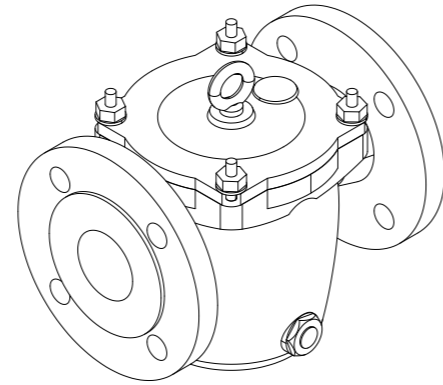

Pressure & Temperature ranges:

Bore	Working Pressure(Bar)
	120°C
DN25-DN450	4
DN500-DN700	2.5

No	Part	Material	Code
1	Body	Bronze	CuSn5Zn5Pb5-C(Rg5)
2	Bonnet	Bronze	CuSn5Zn5Pb5-C(Rg5)
3	Bonnet Gasket	NBR	-
4	Basket	Stainless Steel	1.4401 (AISI 316)
5	Stud Bolt	Stainless Steel	A2(AISI 304)
6	Nut	Stainless Steel	A2(AISI 304)
7	Drain Plug	Stainless Steel	1.4301(AISI 304)

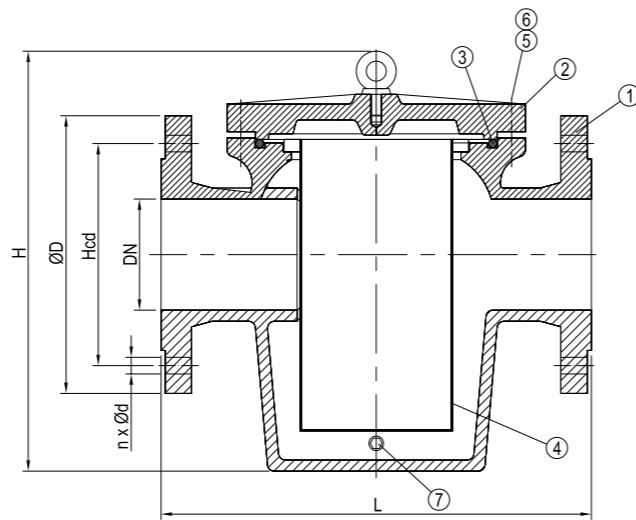

DN	n x ød	Hcd	øD	L	H	Kg
40	4x18	110	150	200	210	12
50	4x18	125	165	230	215	61
65	8x18	145	185	290	265	23
80	8x18	160	200	310	300	28
100	8x18	180	220	350	340	42
125	8x18	210	250	400	415	60
150	8x22	240	285	480	465	75
200	8x22	295	340	600	580	150
250	12x22	350	395	600	620	160
300	12x22	400	445	600 (700)	660	220
350	16x22	460	505	610 (690;800)	750	237
400	16x26	515	565	740	900	330
450	20x26	565	615	1000	1000	520
500	20x26	620	670	1100	1200	860
600	20x30	725	780	1100	1100	940
700	24x30	840	895	1250	1150	1000



MUD BOX

STRAIGHT TYPE, FLANGED ENDS

482051
PN4/PN2.5

DESCRIPTION: Straight type, grey cast iron body and bonnet mud box with AISI 316 strainer basket. Fitted with drain plug and bonnet lifting lug. Raised face flanged.

APPLICATION: Typically used as sea water suction and bilge suction filter etc. Suction and discharge lines for sea cooling water and bilge systems.

STANDARD & DESIGN:

Design Code: DIN 87151 D - With fixed stud and nuts.
 Inspection Std.: -
 End Std.: EN 1092/B (DIN 2501)
 Face to Face Std.: DIN 87151 - Straight Type.
 Flanges drilled: PN 10 (DN25-DN700)
 Pressure rating: PN 4 (DN25-DN450)
 PN 2.5 (DN500-DN700)
 Temperature range: -10°C to +120°C
 Mesh size: 5mm (DN25-DN65)
 8mm (DN80-DN700)

VARIATIONS: CuNiFe strainer basket

Other mesh sizes
 Bonnet air vent
 Other materials on request.

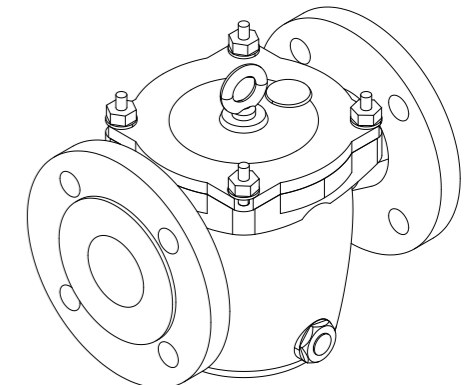

Pressure & Temperature ranges:

Bore	Working Pressure(Bar)
	120°C
DN25-DN450	4
DN500-DN700	2.5

No	Part	Material	Code
1	Body	Cast Iron	EN-GJL250
2	Bonnet	Cast Iron	EN-GJL250
3	Bonnet Gasket	NBR	-
4	Basket	Stainless Steel	AISI 316 (1.4401)
5	Stud Bolt	Steel	-
6	Nut	Steel	-
7	Drain Plug	Brass	-

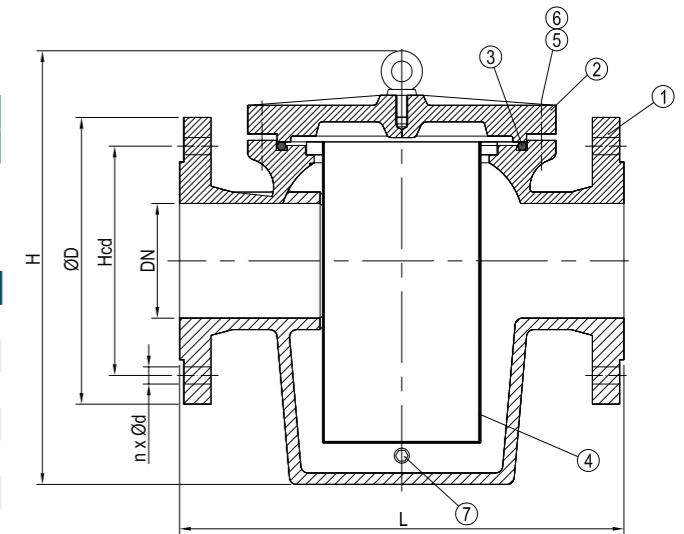

DN	n x ød	Hcd	øD	L	H	Kg
25	4x14	85	115	160	180	5.0
32	4x18	100	140	200	210	8.0
40	4x18	110	150	200	210	8.5
50	4x18	125	165	230	215	12.0
65	8x18	145	185	290	265	16.0
80	8x18	160	200	310	300	20.0
100	8x18	180	220	350	340	28.0
125	8x18	210	250	400	415	39.0
150	8x22	240	285	480	465	62.0
200	8x22	295	340	600	580	103.0
250	12x22	350	395	600	620	141.0
300	12x22	400	445	600 (700)	660	189.0
350	16x22	460	505	610 (690;800)	750	200.0
400	16x26	515	565	740	900	305.0
450	20x26	565	615	1000	1000	500.0
500	20x26	620	670	1100	1200	765.0
600	20x30	725	780	1100	1100	830.0
700	24x30	840	895	1250	1150	900.0



MUD BOX

STRAIGHT TYPE , FLANGED ENDS

482061
PN4

DESCRIPTION: Straight type, hot dip galvanized steel body and bonnet mud box with AISI 316 strainer basket. Fitted with drain plug and bonnet lifting lug. Flat face flanged.

APPLICATION: Typically used as sea water suction and bilge suction filter etc.

STANDARD & DESIGN:

Design Code: DVS 32012-1
 Inspection Std.: -
 End Std.: Flanges drilled according to PN10
 Face to Face Std.: -
 Flanges Drilled: PN10(DN40-DN450)
 Pressure rating: PN4(DN40-DN450)
 Mesh size: To be agreed

VARIATIONS:

Other dimensions and materials on request
 Bonnet air vent

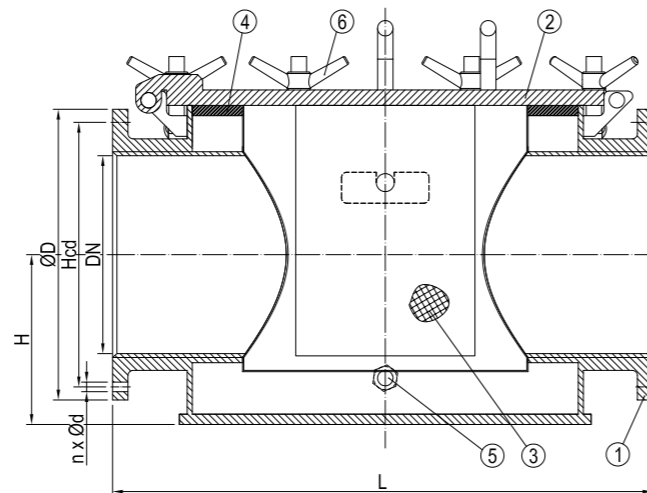
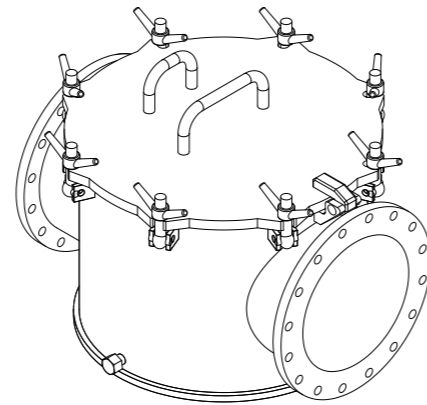

No	Part	Material	Code
1	Body	Hot dip galvanized steel	-
2	Cap	Hot dip galvanized steel	-
3	Strainer	Stainless Steel	SS 316
4	Gasket	NBR	-
5	Plug	Hot dip galvanized steel	-
6	Finger Nut	Brass	-

DN	n x ød	Hcd	øD	L	H	Kg
40	4x18	110	150	290	99	16
50	4x18	125	165	310	114	21
65	4x18	145	185	340	124	25
80	8x18	160	200	390	134	31
100	8x18	180	220	420	142	38
125	8x18	210	250	470	152	49
150	8x22	240	285	510	169	75
200	8x22	295	340	640	186	104
250	12x22	350	395	805	216	149
300	12x22	400	445	880	245	253
350	16x22	460	505	945	258	293
400	16x26	515	565	1060	290	377
450	20x26	565	615	1160	314	438



MUD BOX

ANGLE TYPE, FLANGED ENDS

482121
PN4/PN2.5

DESCRIPTION: Angled type, Rg5 body and bonnet mud box with AISI 316 strainer basket. Fitted with drain plug and bonnet lifting lug. Raised face flanged.

APPLICATION: Typically used as sea water suction and bilge suction filter etc. Suction and discharge lines for sea cooling water and bilge systems.

STANDARD & DESIGN:

Design Code: DIN 87151 E - with drain plug.
 Inspection Std.: -
 End Std.: EN 1092-3/B (DIN 2501)
 Face to Face Std.: DIN 87151 - angle type.
 Flanges drilled: PN10 (DN40-DN600)
 Pressure rating: PN4 (DN25-DN450)
 PN2.5 (DN500-DN600)
 Temperature range: -10°C to +120°C
 Mesh size: 5mm (DN25-DN65)
 8mm (DN80-DN700)

VARIATIONS: CuNiFe strainer basket

Other mesh sizes
 Bonnet air vent
 Other materials on request.

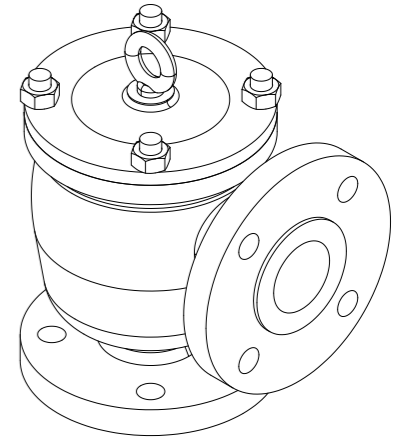

Pressure & Temperature ranges:

Bore	Working Pressure(Bar)
	120°C
DN25-DN450	4
DN500-DN600	2.5

No	Part	Material	Code
1	Body	Bronze	CuSn5Zn5Pb5-C
2	Bonnet	Bronze	CuSn5Zn5Pb5-C
3	Bonnet Gasket	NBR	-
4	Basket	Stainless Steel	AISI 304(1.4301)
5	Stud Bolt	Stainless Steel	A2(AISI 304)
6	Nut	Stainless Steel	A2(AISI 304)
7	Drain Plug	Stainless Steel	1.4301(AISI 304)

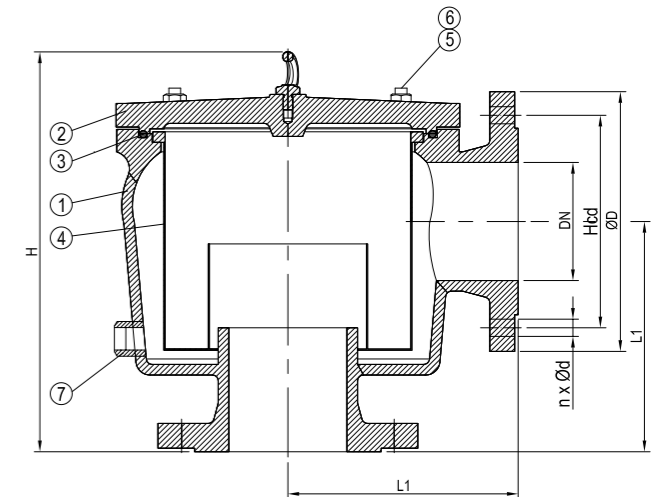

DN	n x ød	Hcd	øD	L1	H	Kg
40	4x18	110	150	125	235	14
50	4x18	125	165	135	255	18
65	8x18	145	185	150	270	22
80	8x18	160	200	175	320	30
100	8x18	180	220	195	345	42
125	8x18	210	250	220	410	70
150	8x22	240	285	270	470	94
200	8x22	295	340	300	535	145
250	12x22	350	395	390	650	170
300	12x22	400	445	450	800	260
350	16x22	460	505	400	735	270
400	16x26	515	565	420/520	940	390
450	20x26	565	615	625	1050	550
500	20x26	620	670	675	1130	630
600	20x30	725	780	620/720	1225	900



MUD BOX

ANGLE TYPE, FLANGED ENDS

482151
PN4/PN2.5

DESCRIPTION: Angled type, grey cast iron body and bonnet mud box with AISI 316 strainer basket. Fitted with drain plug and bonnet lifting lug. Raised face flanged.

APPLICATION: Typically used as sea water suction and bilge suction filter etc. Suction and discharge lines for sea cooling water and bilge systems.

STANDARD & DESIGN:

Design Code:	DIN 87151 E - With fixed studs and nuts
Inspection Std.:	-
End Std.:	EN 1092/B (DIN 2501)
Face to Face Std.:	DIN 87151 - Angle Type
Flanges drilled:	PN10 (DN40-DN600)
Pressure rating:	PN4 (DN25-DN450) PN2.5 (DN500-DN600)
Temperature range:	-10°C to +120°C
Mesh size:	5mm (DN25-DN65) 8mm (DN80-DN700)

VARIATIONS:

CuNiFe strainer basket
Other mesh sizes
Bonnet air vent
Other materials on request.

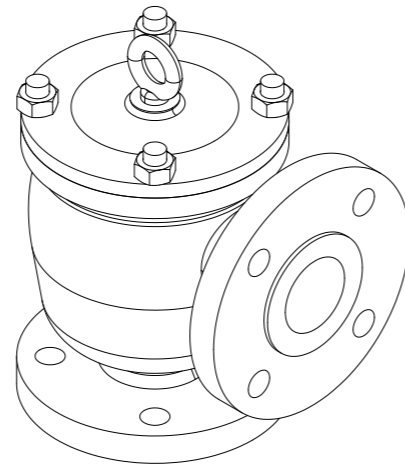

Pressure & Temperature ranges:

Bore	Working Pressure(Bar)
	120°C
DN25-DN450	4
DN500-DN600	2.5

No	Part	Material	Code
1	Body	Cast Iron	EN-GJL250
2	Bonnet	Cast Iron	EN-GJL250
3	Bonnet Gasket	NBR	-
4	Basket	Stainless Steel	AISI 316(1.4401)
5	Stud Bolt	Steel	-
6	Nut	Steel	-
7	Drain Plug	Brass	CuZn39Pb3

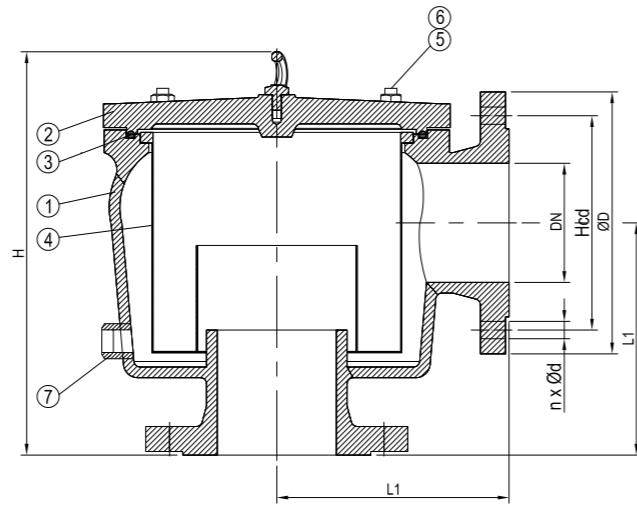

DN	n x ød	Hcd	øD	L1	H	Kg
40	4x18	110	150	125	235	12
50	4x18	125	165	135	255	15
65	8x18	145	185	150	270	20
80	8x18	160	200	175	320	30
100	8x18	180	220	195	345	38
125	8x18	210	250	220	410	62
150	8x22	240	285	270	470	87
200	8x22	295	340	300	535	125
250	12x22	350	395	390	650	165
300	12x22	400	445	450	800	245
350	16x22	460	505	400	735	250
400	16x26	515	565	420/520	940	380
450	20x26	565	615	625	1050	530
500	20x26	620	670	675	1130	590
600	20x30	725	780	620/720	1225	850



MUD BOX

ANGLE TYPE, FLANGED ENDS

482161
PN4

DESCRIPTION: Angled type, hot dip galvanized steel body and bonnet mud box with AISI 316 strainer basket. Fitted with drain plug and bonnet lifting lug. Flat face flanged.

APPLICATION: Typically used as sea water suction and bilge suction filter etc.

STANDARD & DESIGN:

Design Code:	DVS 32013
Inspection Std.:	-
End Std.:	Flanges drilled according to PN10
Face to Face Std.:	-
Flanges Drilled:	PN10(DN40-DN450)
Pressure rating:	PN4(DN40-DN450)
Mesh size:	To be agreed

VARIATIONS:

Other dimensions and materials on request
Bonnet air vent

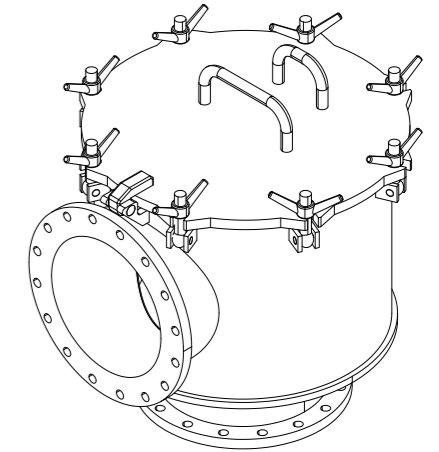

No	Part	Material	Code
1	Body	Hot dip galvanized steel	-
2	Cap	Hot dip galvanized steel	-
3	Strainer	Stainless Steel	SS 316
4	Gasket	NBR	-
5	Finger Nut	Brass	-

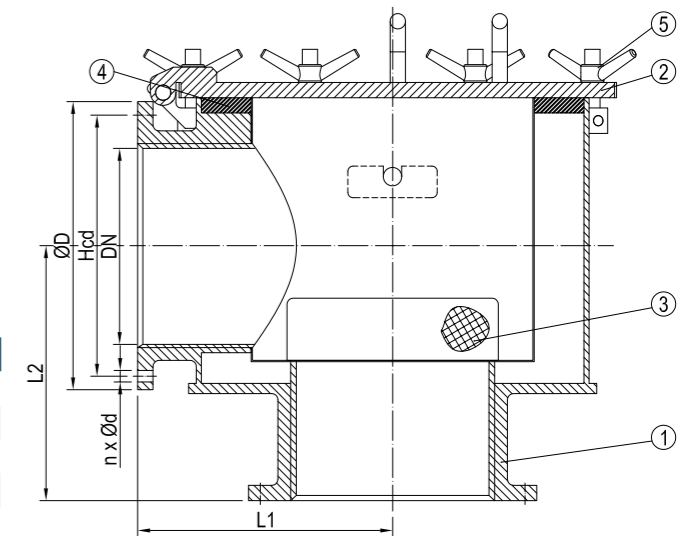

DN	n x ød	Hcd	øD	L1	L2	Kg
40	4x18	110	150	145	180	16
50	4x18	125	165	155	200	20
65	4x18	145	185	170	210	24
80	8x18	160	200	195	225	30
100	8x18	180	220	210	240	36.5
125	8x18	210	250	235	255	47.5
150	8x22	240	285	255	275	73.5
200	8x22	295	340	320	295	102
250	12x22	350	395	380	330	148
300	12x22	400	445	415	365	216
350	16x22	460	505	445	453	274
400	16x26	515	565	500	500	348
450	20x26	565	615	550	525	383



STRAINER

Y-TYPE, THREADED ENDS

482294
800WOG

DESCRIPTION: Y-type, AISI 316 equivalent body strainer with AISI 304 strainer basket. With drain plug. BSPP female thread.

APPLICATION: Filtering of water, oils, process liquids in general etc.

STANDARD & DESIGN:

Design Code: -
 Inspection Std.: -
 End Std.: ISO 228 Class A
 Face to Face Std.: -
 Pressure rating: 800WOG(DN8-DN80)
 Mesh size: 20 mesh

VARIATIONS: Other mesh sizes

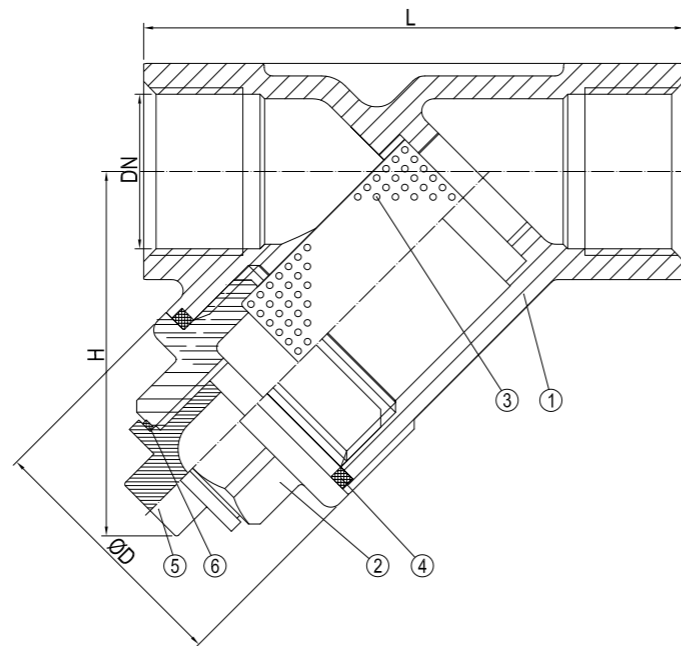
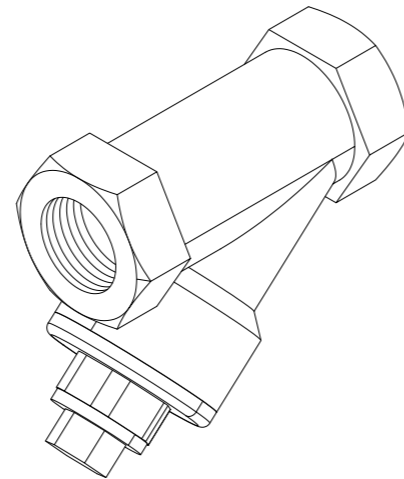
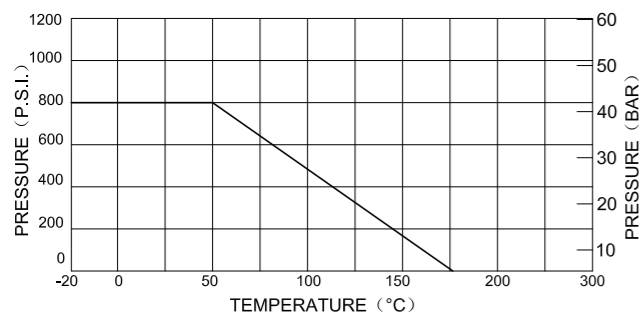

No	Part	Material	Code
1	Body	Stainless Steel	CF8M
2	Cap	Stainless Steel	CF8M
3	Screen	Stainless Steel	SUS 316
4	Gasket	PTFE	-
5	Plug	Stainless Steel	CF8M
6	Gasket	PTFE	-

DN	Inch	L	H	øD	Kg
8	1/4	65	45	31	0.3
10	3/8	65	45	31	0.2
15	1/2	65	45	31	0.2
20	3/4	80	53	36	0.4
25	1	90	68	45	0.7
32	1 1/4	105	72	50	0.9
40	1 1/2	120	80	59	1.4
50	2	140	97	75	2.4
65	2 1/2	170	112	95	4.7
80	3	195	129	113	7.3



STRAINER

Y-TYPE, THREADED ENDS

482322
PN16

DESCRIPTION: Y-type, Rg5 body, strainer with AISI 304 strainer basket. BSPP female thread.

APPLICATION: Filtering of water, oils, non aggressive process liquids etc.

STANDARD & DESIGN:

Design Code: -
 Inspection Std.: EN 12516-3:2003
 End Std.: UNI ISO 228-1:2003
 Face to Face Std.: -
 Pressure rating: PN16(DN15-DN100)
 Temperature Range: 0°C to 95°C
 Mesh size: 50 mesh (DN15-DN25)
 40 mesh (DN32-DN50)
 18 mesh (DN65-DN100)

VARIATIONS: Other mesh sizes
 Other materials on request

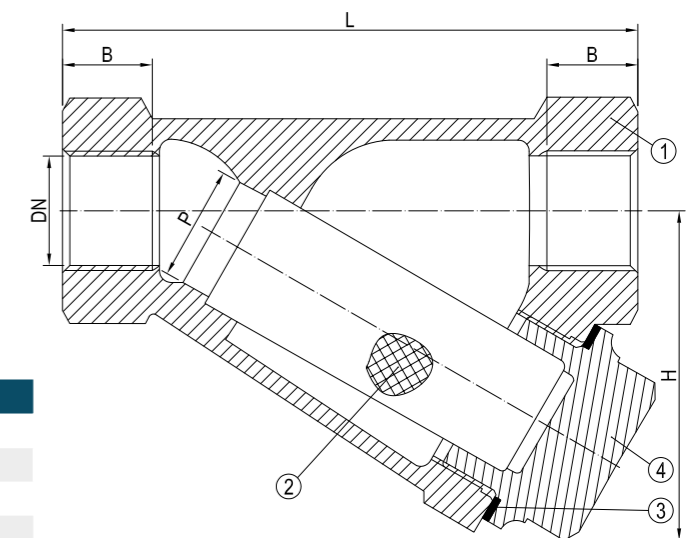
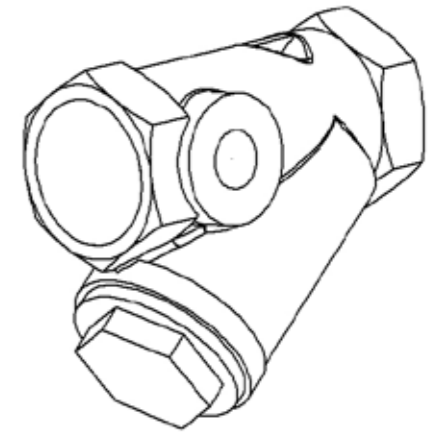

No	Part	Material	Code
1	Body	Bronze	CC491K
2	Screen	Stainless Steel	AISI 304
3	Gasket	Silc 4400	-
4	Plug	Brass	CW614N

DN	Inch	L	H	B	P	Kg
15	1/2	65	42	12	16	0.3
20	3/4	83	45	14	20	0.4
25	1	92	53	15	24	0.5
32	1 1/4	105	65	16	29	0.7
40	1 1/2	115	73	18	37	0.9
50	2	131	95	20	46	0.2
65	2 1/2	146	105	19.5	62	0.3
80	3	172	128	20	68	0.4
100	4	226	178	22	92	0.7



STRAINER

FLANGED ENDS

483322
PN16

DESCRIPTION: Y-type, Rg5 body strainer with AISI 304 strainer basket. Flat face flanged.

APPLICATION: Filtering of water, oils, process liquids in general etc.

STANDARD & DESIGN:

Design Code:	-
Inspection Std.:	-
End Std.:	UNI EN 1092-3:2005
Face to Face Std.:	-
Flanges Drilled:	PN16(DN15-DN100)
Pressure rating:	PN16(DN15-DN100)
Temperature Range:	-10°C to 180°C (Water) -10°C to 60°C (Oxygen)
Mesh size:	0,4mm (DN15-DN25) 0,8mm (DN32-DN50) 1,2mm (DN65) 1,5mm (DN80-DN100)

VARIATIONS: Other mesh sizes.
Other materials on request.

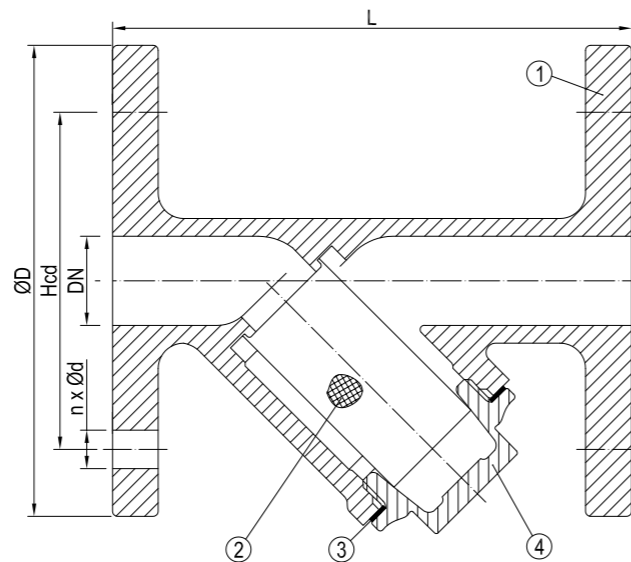
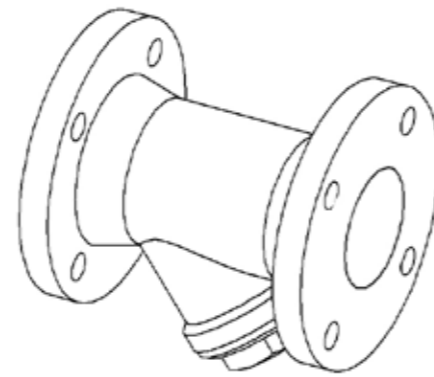

No	Part	Material	Code
1	Body	Bronze	CC491K
2	Screen	Stainless Steel	AISI 304
3	Gasket	Silc 4400	-
4	Plug	Brass	CW614N

DN	n x ød	Hcd	øD	L	Kg
15	4x14	65	95	100	1.7
20	4x14	75	105	115	2.0
25	4x14	85	115	140	2.5
32	4x18	100	140	145	4.2
40	4x18	110	150	170	5.2
50	4x18	125	165	185	6.8
65	4x18	145	185	205	8.8
80	8x18	160	200	220	10.5
100	8x18	180	220	254	14.0



STRAINER

Y-TYPE, FLANGED ENDS

483402/01
PN16/PN10

DESCRIPTION: Y-type, nodular cast iron body strainer with AISI 304 strainer basket. Raised face flanged.

APPLICATION: Filtering of water, oils, non aggressive process liquids in general etc.
Water, oil and other process liquids.

STANDARD & DESIGN:

Design Code:	-
Inspection Std.:	-
End Std.:	EN 1092/B (DIN 2501)
Face to Face Std.:	EN 558 series 1 (DIN 3202 F1)
Flanges drilled:	PN16 (DN15-DN150) PN10 (DN200-DN500)
Pressure rating:	PN16 (DN15-DN150) PN10 (DN200-DN500)
Temperature range:	-10°C to +120°C
Mesh size:	1mm

VARIATIONS: Other mesh sizes.
Other materials on request.

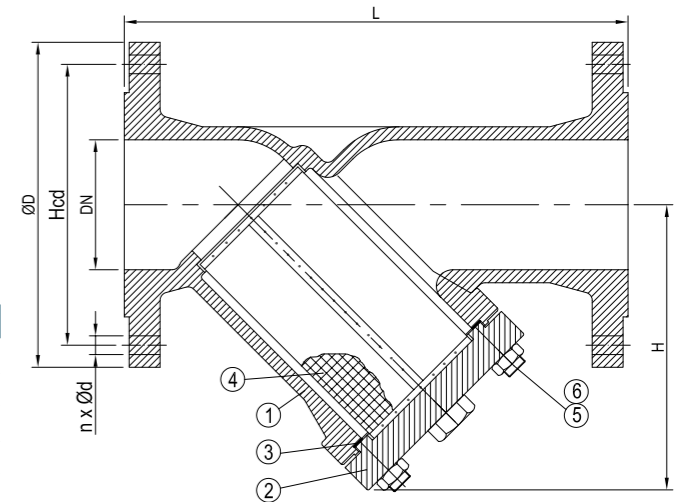
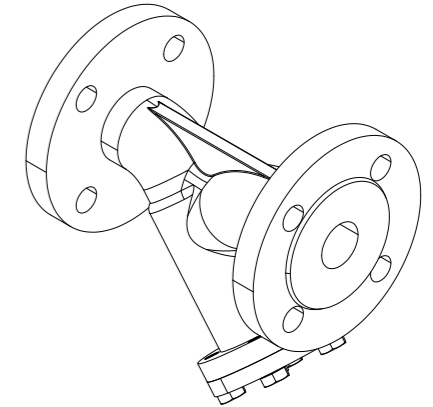

No	Part	Material	Code
1	Body	Nodular Cast Iron	EN-GJS400-18-LT
2	Bonnet	Nodular Cast Iron	EN-GJS400-18-LT
3	Bonnet Gasket	Graphite	-
4	Screen	Stainless Steel	AISI 304(1.4301)
5	Stud Bolt	Steel	-
6	Nut	Steel	-

DN	n x ød	Hcd	øD	L	H	Kg
15	4x14	65	95	130	75	3.0
20	4x14	75	105	150	80	3.5
25	4x14	85	115	160	90	4.5
32	4x18	100	140	180	90	5.5
40	4x18	110	150	200	110	8.0
50	4x18	125	165	230	120	10.0
65	4x18	145	185	290	140	15.0
80	8x18	160	200	310	170	22.0
100	8x18	180	220	350	220	32.0
125	8x18	210	250	400	260	43.0
150	8x22	240	285	480	300	60.0
200	8x22	295	340	600	370	90.0
250	12x22	350	395	730	440	155.0
300	12x22	400	445	850	525	180.0
350	16x22	460	505	980	590	250.0
400	16x26	515	565	1100	680	320.0
500	20x26	620	670	1250	985	430.0



STRAINER

Y-TYPE, FLANGED ENDS

483452/51
PN16/PN10

DESCRIPTION: Y-type, grey cast iron body strainer with AISI 304 strainer basket. With drain plug. Raised face flanged.

APPLICATION: Filtering of water, oils, non aggressive process liquids in general etc.
Water, oil and other process liquids.

STANDARD & DESIGN:

Design Code: -
 Inspection Std.: -
 End Std.: EN 1092/B (DIN 2501)
 Face to Face Std.: EN 558 series 1 (DIN 3202 F1)
 Flanges drilled: PN16 (DN15-DN150)
 PN10 (DN200-DN500)
 Pressure rating: PN16 (DN15-DN150)
 PN10 (DN200-DN500)
 Temperature range: -10°C to +120°C
 Mesh size: 1mm

VARIATIONS: Other mesh sizes.
Other materials on request.

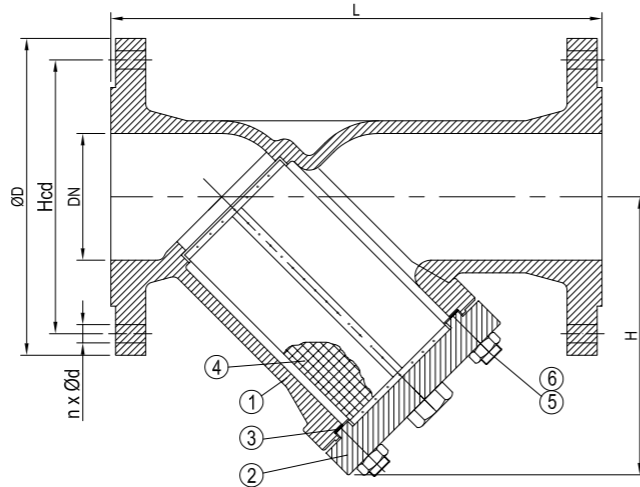
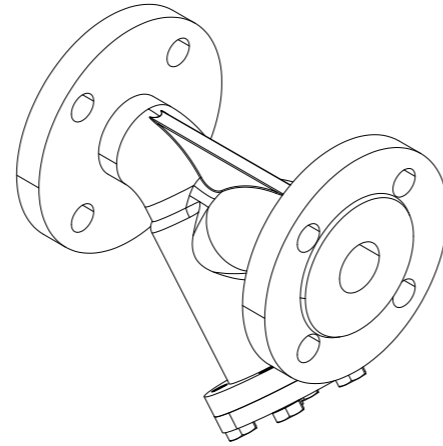

No	Part	Material	Code
1	Body	Cast Iron	EN-GJL250
2	Bonnet	Cast Iron	EN-GJL250
3	Bonnet Gasket	Graphite	-
4	Screen	Stainless Steel	AISI 304(1.4301)
5	Stud Bolt	Steel	-
6	Nut	Steel	-

DN	n x ød	Hcd	øD	L	H	Kg
15	4x14	65	95	130	75	3.0
20	4x14	75	105	150	80	3.5
25	4x14	85	115	160	90	4.5
32	4x18	100	140	180	90	5.5
40	4x18	110	150	200	110	8.0
50	4x18	125	165	230	120	10.0
65	4x18	145	185	290	140	15.0
80	8x18	160	200	310	170	22.0
100	8x18	180	220	350	220	32.0
125	8x18	210	250	400	260	43.0
150	8x22	240	285	480	300	60.0
200	8x22	295	340	600	370	90.0
250	12x22	350	395	730	440	155.0
300	12x22	400	445	850	525	180.0
350	16x22	460	505	980	590	250.0
400	16x26	515	565	1100	680	320.0
500	20x26	620	670	1250	985	430.0



STRAINER

Y-TYPE, FLANGED ENDS

483464/63
PN40/PN25

DESCRIPTION: Y-type, cast steel body strainer with AISI 304 strainer basket. Raised face flanged.

APPLICATION: Filtering of water, oils, non aggressive process liquids in general etc.

STANDARD & DESIGN:

Design Code: -
 Inspection Std.: EN 12266-1
 End Std.: EN 1092-1
 Face to Face Std.: -
 Flanges Drilled: PN40(DN15-DN150)
 PN25(DN200-DN250)
 Pressure rating: PN40(DN15-DN150)
 PN25(DN200-DN250)
 Mesh size: 1mm

VARIATIONS: Other mesh sizes.

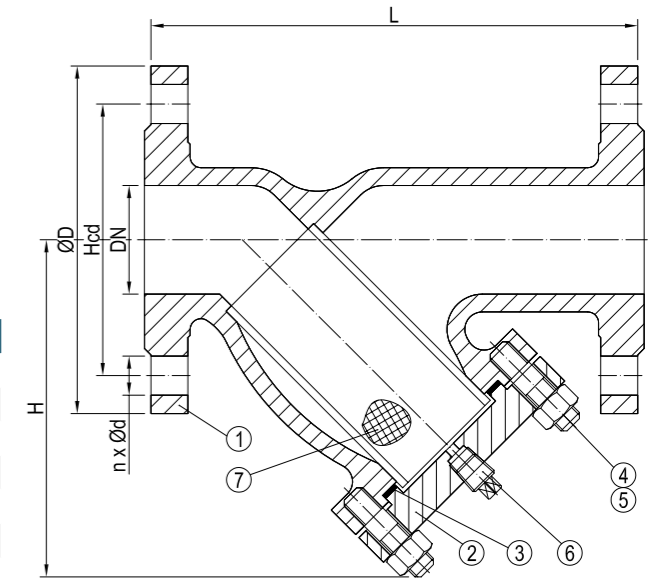
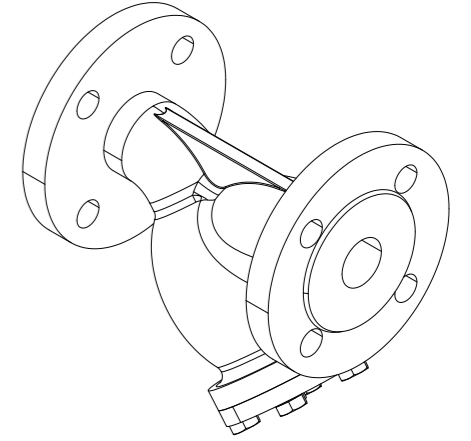

No	Part	Material	Code
1	Body	Cast Steel	ASTM A216-WCB
2	Bonnet	Cast Steel	ASTM A216-WCB
3	Bonnet Gasket	Graphite	-
4	Stud Bolt	Steel	ASTM A193 Gr.B7
5	Nut	Steel	ASTM A194 Gr.2H
6	Plug	Carbon Steel	-
7	Screen	Stainless Steel	SS304

DN	n x ød	Hcd	øD	L	H	Kg
15	4x14	65	95	130	87	2.8
20	4x14	75	105	150	105	3.1
25	4x14	85	115	160	114	4.1
32	4x18	100	140	180	124	5.5
40	4x18	110	150	200	156	7.0
50	4x18	125	165	230	181	10.0
65	8x18	145	185	290	250	22.7
80	8x18	160	200	310	280	27.4
100	8x22	190	235	350	320	38.3
125	8x26	220	270	400	374	56.9
150	8x26	250	300	480	430	72.0
200	12x26	310	360	600	515	93.3
250	12x30	370	425	730	-	-



STRAINER

Y-TYPE, FLANGED ENDS

483492/91
PN16/PN10

DESCRIPTION: Y-type, AISI 316 equivalent body strainer with AISI 316 strainer basket. Raised face flanged.

APPLICATION: Filtering of water, oils, process liquids in general etc.

STANDARD & DESIGN:

Design Code: ASME B16.34
 Inspection Std.: EN 12266-1
 End Std.: DIN2633
 Face to Face Std.: DIN3202-F1
 Flanges Drilled: PN16(DN15-DN150)
 PN10(DN200-DN300)
 Pressure rating: PN16(DN15-DN150)
 PN10(DN200-DN300)
 Mesh size: 20 mesh

VARIATIONS: DN200-DN300 available in PN16
 Other mesh sizes.

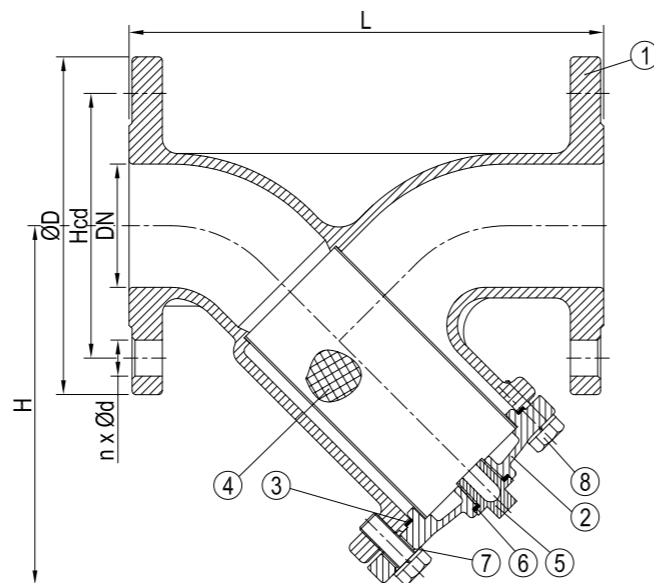
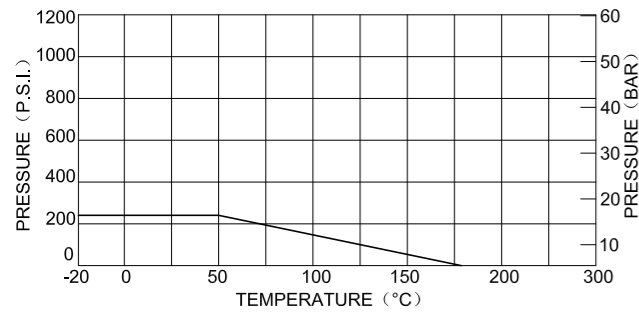
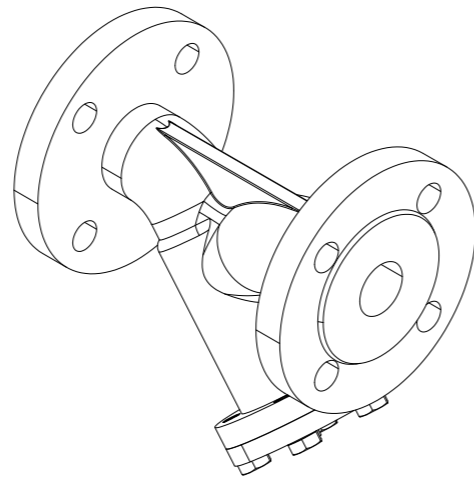

No	Part	Material	Code
1	Body	Stainless Steel	1.4408
2	Cap	Stainless Steel	1.4408
3	Gasket	PTFE	-
4	Screen	Stainless Steel	SUS 316
5	Stopper	Stainless Steel	1.4408
6	Gasket	PTFE	-
7	Spring Washers	Stainless Steel	SUS 304
8	Bonnet Bolt	Stainless Steel	SUS 304

DN	n x ød	Hcd	øD	L	H	Kg
15	4x14	65	95	130	85	2.3
20	4x14	75	105	150	87	2.8
25	4x14	85	115	160	114	3.9
32	4x18	100	140	180	114	5.3
40	4x18	110	150	200	135	6.3
50	4x18	125	165	230	155	8.3
65	4x18	145	185	290	189	11.8
80	8x18	160	200	310	200	15.6
100	8x18	180	220	350	232	21.0
125	8x18	210	250	400	274	29.0
150	8x22	240	285	480	326	41.0
200	8x22	295	340	600	397	73.4
250	12x22	350	395	730	512	128.0
300	12x22	400	445	850	562	184.0



BASKET STRAINER

FLANGED ENDS

483662/61
PN16/PN10

DESCRIPTION: Straight type cast steel body strainer with AISI 304 strainer basket. With drain plug. Raised face flanged.

APPLICATION: Filtering of water, oils, non aggressive process liquids in general etc.

STANDARD & DESIGN:

Design Code: -
 Inspection Std.: EN12266-1
 End Std.: EN1092-1
 Face to Face Std.: -
 Flanges Drilled: PN16(DN25-DN150)
 PN10(DN200-DN300)
 Pressure rating: PN16(DN25-DN150)
 PN10(DN200-DN300)
 Mesh size: 40 mesh

VARIATIONS: DN200-DN300 available in PN16
 Other mesh sizes (1, 2 or 3mm)

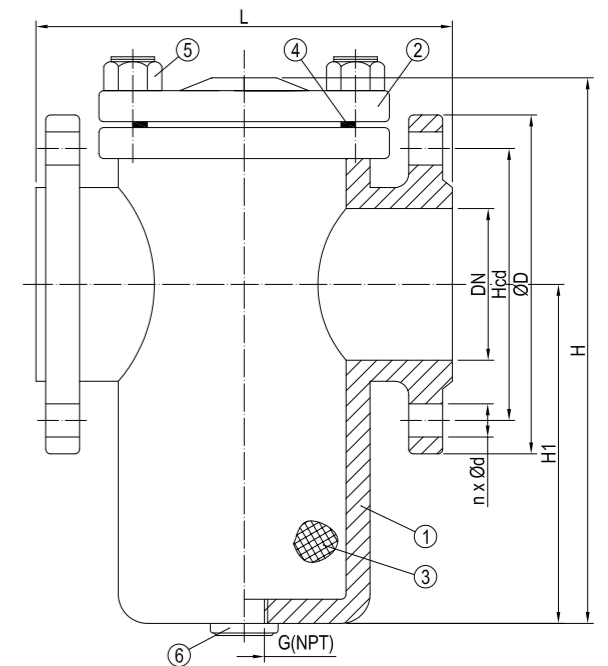
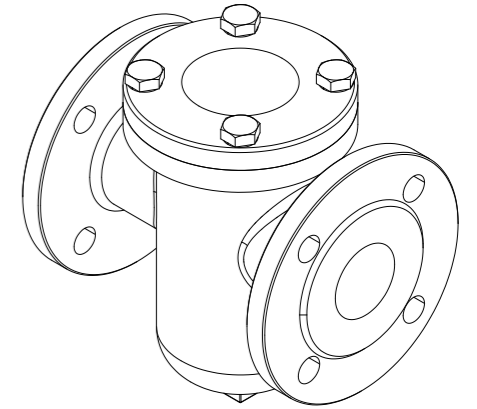

No	Part	Material	Code
1	Body	Steel	EN1503-1/1.0619
2	Cap	Steel	EN1503-1/1.0619
3	Screen	Stainless Steel	SUS 304
4	Gasket	PTFE	-
5	Bolt	Steel	ASTM A193 B7
6	Plug	Cast Steel	ASTM A216 Gr. WCB

DN	n x ød	Hcd	øD	G(Inch)	L	H	H1	Kg
25	4x14	85	115	1/2	152	174	77	7.8
40	4x18	110	150	1/2	173	216	120	10.6
50	4x18	125	165	1	210	216	120	13.0
65	4x18	145	185	1	222	260	160	15.0
80	8x18	160	200	1	254	306	200	21.0
100	8x18	180	220	1	290	390	254	28.0
125	8x18	210	250	1	336	430	280	44.0
150	8x22	240	285	1	400	410	270	48.0
200	8x22	295	340	1	500	560	340	88.9
250	12x22	350	395	2	508	685	360	128.0
300	12x22	400	445	2	666	760	420	-



BASKET STRAINER

483692/91
PN16/PN10
FLANGED ENDS

DESCRIPTION: Straight type AISI 316 equivalent body strainer with AISI 304 strainer basket. With drain plug. Raised face flanged.

APPLICATION: Filtering of water, oils, process liquids in general etc.

STANDARD & DESIGN:

Design Code: -
 Inspection Std.: EN12266-1
 End Std.: EN1092-1
 Face to Face Std.: -
 Flanges Drilled: PN16(DN25-DN150)
 PN10(DN200-DN300)
 Pressure rating: PN16(DN25-DN150)
 PN10(DN200-DN300)
 Mesh size: 40 mesh

VARIATIONS: DN200-DN300 available in PN16
 Other mesh sizes (1, 2 or 3mm)

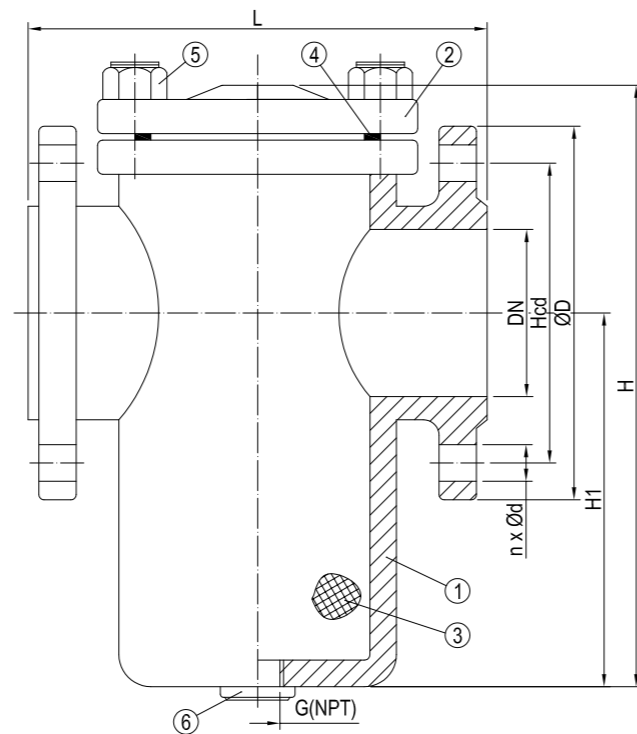
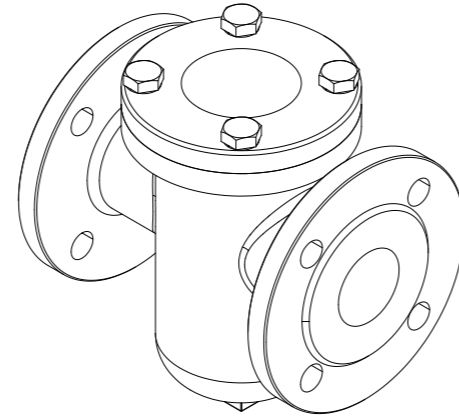

No	Part	Material	Code
1	Body	Stainless Steel	EN1503-1/1.4408
2	Cap	Stainless Steel	EN1503-1/1.4408
3	Screen	Stainless Steel	SUS 304
4	Gasket	PTFE	-
5	Bolt	Steel	ASTM A193 B8
6	Plug	Stainless Steel	SS316

DN	n x ød	Hcd	øD	G(Inch)	L	H	H1	Kg
25	4x14	85	115	1/2	152	174	77	7.8
40	4x18	110	150	1/2	173	216	120	10.6
50	4x18	125	165	1	210	216	120	13.0
65	4x18	145	185	1	222	260	160	15.0
80	8x18	160	200	1	254	306	200	21.0
100	8x18	180	220	1	290	390	254	28.0
125	8x18	210	250	1	336	430	280	44.0
150	8x22	240	285	1	400	410	270	48.0
200	8x22	295	340	1	500	560	340	88.9
250	12x22	350	395	2	508	685	360	128.0
300	12x22	400	445	2	666	760	420	-



DUAL FILTER

483852/51
PN16/PN10
FLANGED ENDS

DESCRIPTION: Straight type grey cast iron dual filter with AISI 316 baskets. With handle for easy switch over. Drain plugs. Raised face flanges.

APPLICATION: Filtering of water, oils, non aggressive process liquids in general etc.

STANDARD & DESIGN:

Design Code: -
 Inspection Std.: -
 End Std.: -
 Face to Face Std.: -
 Flanges Drilled: PN16(DN25-DN150)
 PN10(DN200)
 Pressure rating: PN16(DN25-DN150)
 PN10(DN200)
 Mesh size: 40 mesh

VARIATIONS: Other mesh sizes
 Other materials on request.

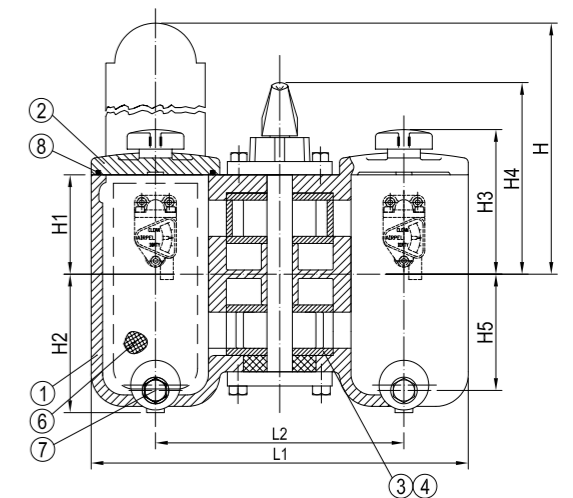
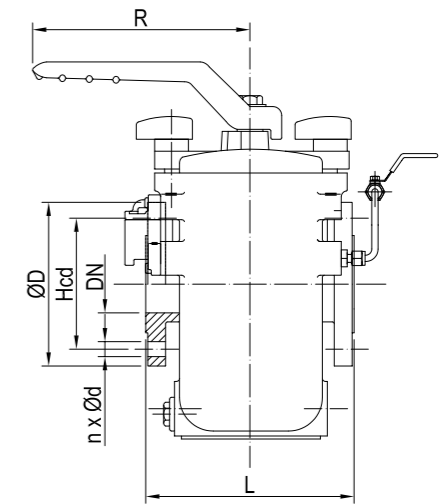
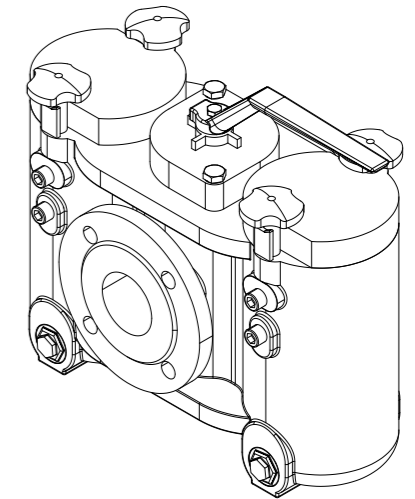

No	Part	Material	Code
1	Body	Cast Iron	EN1561/EN-JL 1030
2	Cover	Cast Iron	EN1561/EN-JL 1030
3	Sleeve	-	-
4	Change Over Cocks	SG Iron	EN1563/EN-JS 1020
5	Internal Machine Part	Mild Steel	BS970 220 M07
6	Baskets	Stainless Steel	BS1449 316
7	Drain Plugs	Brass	-
8	Seals	Viton	-

DN	n x ød	Hcd	øD	L	L1	L2	H	H1	H2	H3	H4	H5	R	Kg
25	4x14	85	115	152	282	170	220	64	105	103	149	86	205	16
40	4x18	110	150	175	295	184	306	90	145	132	175	122	205	23
50	4x18	125	165	210	425	280	351	112	156	165	212	131	219	52
65	4x18	145	185	230	425	280	351	112	156	165	212	131	219	53
80	8x18	160	200	267	490	330	451	140	210	198	256	186	250	85
100	8x18	180	220	318	540	380	575	175	265	233	294	241	250	125
150	8x22	240	285	380	760	530	868	275	410	-	398	359	380	250
200	8x22	295	340	570	1020	700	1210	390	520	-	550	472	500	730

WOG (Water-Oil-Gas) is a common general marking on valves and is often used for ball valves for a do-not-exceed pressure in psi. This should also be considered as a maximum pressure rating in normal ambient temperature. To convert WOG/psi to bar one can multiply the psi figure with 0,07 to get an approximate do-not-exceed bar figure which is not to be mistaken as PN-rating. (1 bar equals 14.50377 psi in differential pressure)



BALL VALVES & PLUG VALVES

For shut off purposes. Can also be delivered as 3-way and 4-way valves.
Available with threaded, flanged or weld end connections.
Metal to metal sealing or soft sealing.
Available with different types of actuators.



PLUG VALVE

THREE-WAY, FLANGED ENDS

394451
PN10

DESCRIPTION: 3-way grey cast iron body plug valve with grey cast iron plug. Raised face flanged and free stem.

APPLICATION: Stop and distribution valve for: Compressed air, gases, non corrosive media and slurries etc.

STANDARD & DESIGN:

Design Code: DIN 3472
 Inspection Std.: -
 End Std.: DIN PN10
 Face to Face Std.: DIN 3202/EN 558 F1
 Flanges drilled: PN10(DN15-DN150)
 Pressure rating: PN10(DN15-DN150)

VARIATIONS: Available with both L-port and T-port plug.
 Handlever optional

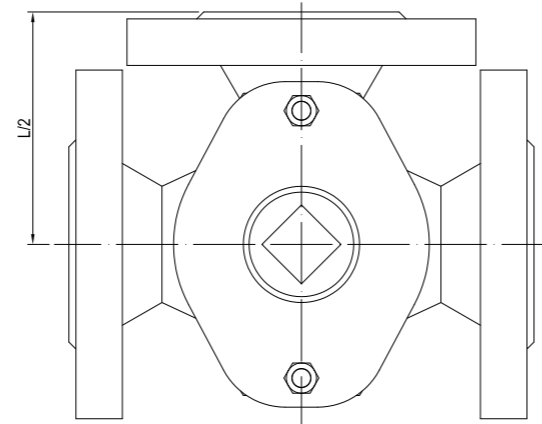
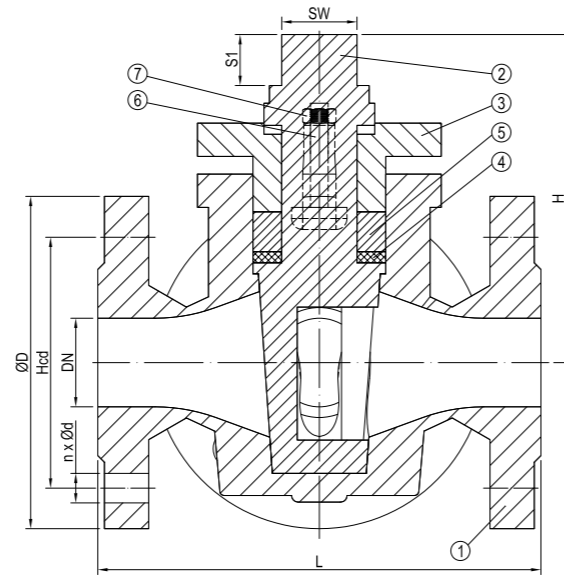
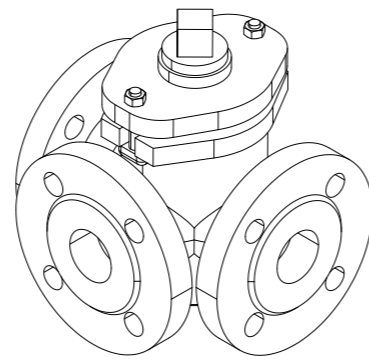

No	Part	Material	Code
1	Body	Cast Iron	EN-GJL-250
2	Plug	Cast Iron	EN-GJL-250
3	Gland	Cast Iron	EN-GJL-250
4	Disc	Steel	S235 JR
5	Packing	Graphite	-
6	Hammer Head Screw	Steel	S235 JR
7	Hex Nut	Steel	S235 JR

DN	n x ød	Hcd	øD	L	H	SW	S1	Kg
15	4x14	65	95	130	90	12	13	2.3
20	4x14	75	105	150	102	17	18	4.3
25	4x14	85	115	160	117	19	19	5.0
32	4x18	100	140	180	141	22	22	8.9
40	4x18	110	150	200	148	24	23	10.0
50	4x18	125	165	230	176	32	28	16.0
65	4x18	145	185	290	215	41	40	24.0
80	8x18	160	200	310	250	46	44	31.0
100	8x18	180	220	350	281	55	53	45.0
125	8x18	210	250	400	340	60	57	84.0
150	8x22	240	285	480	400	65	61	110.0



PLUG VALVE

THREE-WAY, FLANGED ENDS

394551
PN10

DESCRIPTION: 3-way grey cast iron body plug valve with Rg5 plug. Raised face flanged and free stem.

APPLICATION: Stop and distribution valve for: Compressed air, gases, liquids in general and slurries etc.

STANDARD & DESIGN:

Design Code: DIN 3472
 Inspection Std.: -
 End Std.: DIN PN10
 Face to Face Std.: DIN 3202/EN 558 F1
 Flanges drilled: PN10(DN15-DN150)
 Pressure rating: PN10(DN15-DN150)

VARIATIONS: Available with both L-port and T-port plug.
 Handlever optional

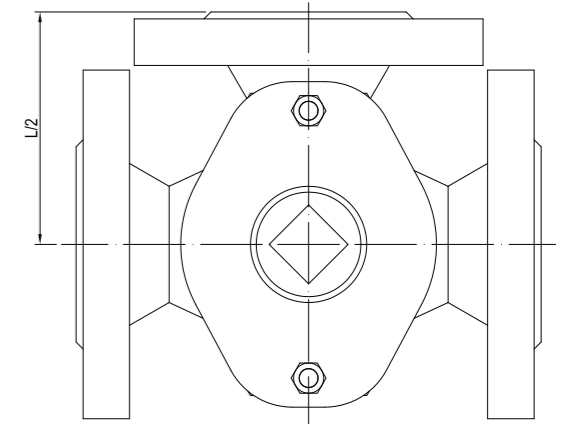
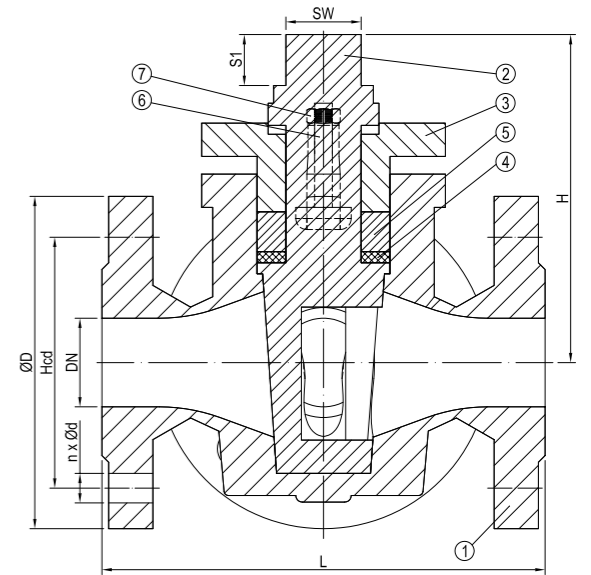
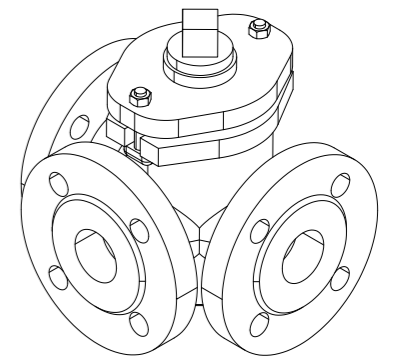

No	Part	Material	Code
1	Body	Cast Iron	EN-GJL-250
2	Plug	Bronze	CuSn5Zn5Pb5-C
3	Gland	Cast Iron	EN-GJL-250
4	Disc	Steel	S235 JR
5	Packing	Graphite	-
6	Hammer Head Screw	Steel	S235 JR
7	Hex Nut	Steel	S235 JR

DN	n x ød	Hcd	øD	L	H	SW	S1	Kg
15	4x14	65	95	130	90	12	13	2.3
20	4x14	75	105	150	102	17	18	4.3
25	4x14	85	115	160	117	19	19	5.0
32	4x18	100	140	180	141	22	22	8.9
40	4x18	110	150	200	148	24	23	10.0
50	4x18	125	165	230	176	32	28	16.0
65	4x18	145	185	290	215	41	40	24.0
80	8x18	160	200	310	250	46	44	31.0
100	8x18	180	220	350	281	55	53	45.0
125	8x18	210	250	400	340	60	57	84.0
150	8x22	240	285	480	400	65	61	110.0



BALL VALVE

3-PC., FULL BORE, THREADED ENDS

440065
1200WOG/
1000WOG

DESCRIPTION: Three piece, full bore, cast steel body ball valve with AISI 304 ball and PTFE seat ring. BSPP female thread.

APPLICATION: Start/stop flow of: Compressed air, steam, gases and liquids. Typically also used for drain and vent purposes.

STANDARD & DESIGN:

Design Code: -
Inspection Std.: -
End Std.: ISO 228
Face to Face Std.: -
Top Flange: ISO 5211(DN8-DN100)
Pressure rating: 1200 WOG(DN8-DN40)
1000 WOG(DN50-DN100)

VARIATIONS: Various actuators.
Other dimensions and materials on request.

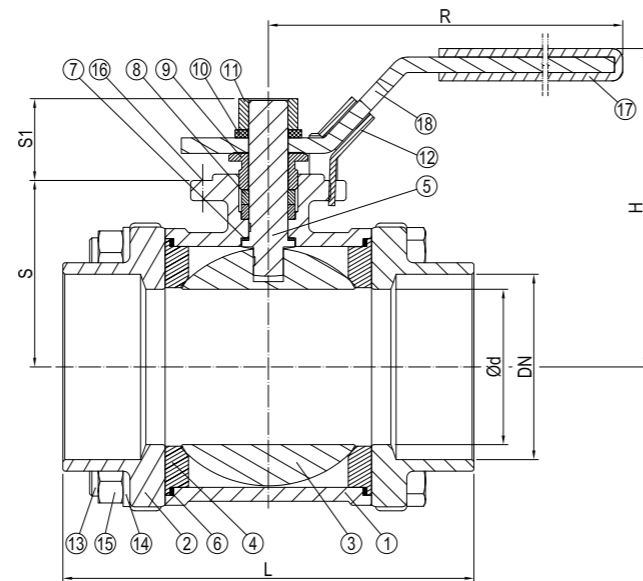
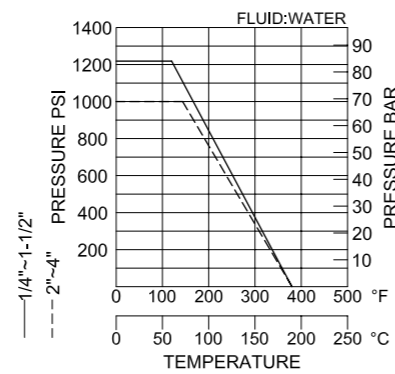
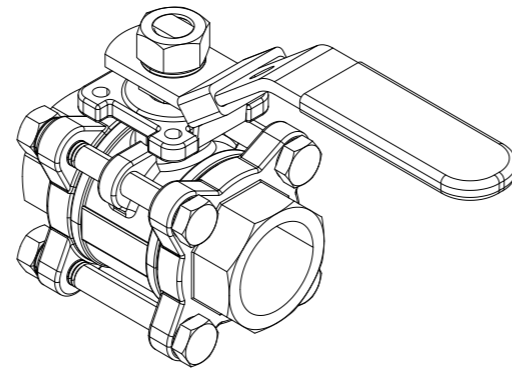

No	Part	Material	Code
1	Body	Cast Steel	ASTM-A216-WCB
2	Bonnet	Cast Steel	ASTM-A216-WCB
3	Ball	Stainless Steel	ASTM-A351-CF8
4	Ball Seat	PTFE	-
5	Stem	Stainless Steel	AISI 316
6	Joint Gasket	PTFE	-
7	Thrust Washer	PTFE	-
8	Stem Packing	PTFE	-
9	Gland Nut	Stainless Steel	AISI 304
10	Stem Washer	Stainless Steel	AISI 304
11	Stem Nut	Stainless Steel	AISI 304
12	Lock Device	Stainless Steel	AISI 304
13	Bolt	Stainless Steel	AISI 304
14	Spring Washer	Stainless Steel	AISI 304
15	Hex Nut	Stainless Steel	AISI 304
16	Stop Pin	Stainless Steel	AISI 304
17	Handle Cover	Plastic	-
18	Handle	Stainless Steel	AISI 430

DN	Inch	L	H	ød	S	S1	R	Kg
8	1/4	58.2	55	11.6	26.5	13.3	95	0.4
10	3/8	58.2	55	12.7	26.5	13.3	95	0.4
15	1/2	62	60	15	30.5	15.8	95	0.5
20	3/4	76	63	20	33	18.3	110	0.7
25	1	85	79	25	39.5	21.5	135	1.1
32	1 1/4	100	86	32	43.5	23	135	1.6
40	1 1/2	115	94	38	52	25	165	2.4
50	2	132.2	103	50	62	23.1	165	3.4
65	2 1/2	165	133	65	77	41.2	285	6.9
80	3	183	144	80	90	39.7	285	11.7
100	4	231.4	177	100	110	47.1	295	22.2



BALL VALVE

3-PC., FULL BORE, THREADED ENDS

440095
1200WOG/
1000WOG

DESCRIPTION: Three piece, full bore, AISI 316 body ball valve with AISI 316 ball and PTFE seat ring. BSPP female thread.

APPLICATION: Start/stop flow of: Compressed air, steam, gases and acidic media etc. Typically also used for drain and vent purposes.

STANDARD & DESIGN:

Design Code: -
Inspection Std.: -
End Std.: ISO 228
Face to Face Std.: -
Top Flange: ISO 5211(DN8-DN100)
Pressure rating: 1200 WOG(DN8-DN40)
1000 WOG(DN50-DN100)

VARIATIONS: Various actuators.
Other dimensions and materials on request.

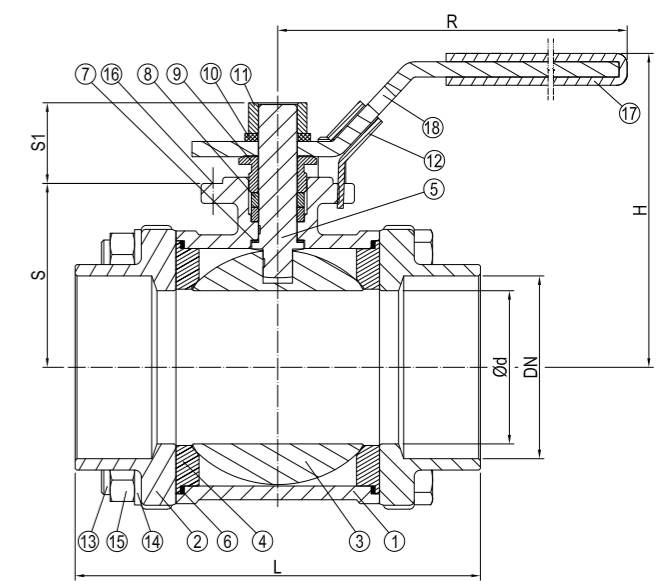
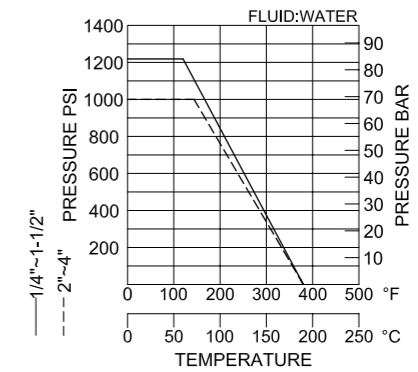
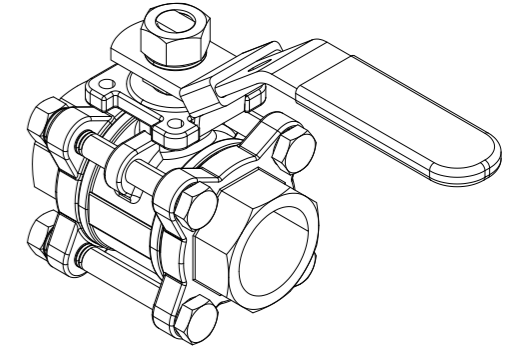

No	Part	Material	Code
1	Body	Stainless Steel	ASTM-A351-CF8M
2	Bonnet	Stainless Steel	ASTM-A351-CF8M
3	Ball	Stainless Steel	ASTM-A351-CF8M
4	Ball Seat	PTFE	-
5	Stem	Stainless Steel	AISI 316
6	Joint Gasket	PTFE	-
7	Thrust Washer	PTFE	-
8	Stem Packing	PTFE	-
9	Gland Nut	Stainless Steel	AISI 304
10	Stem Washer	Stainless Steel	AISI 304
11	Stem Nut	Stainless Steel	AISI 304
12	Lock Device	Stainless Steel	AISI 304
13	Bolt	Stainless Steel	AISI 304
14	Spring Washer	Stainless Steel	AISI 304
15	Hex Nut	Stainless Steel	AISI 304
16	Stop Pin	Stainless Steel	AISI 304
17	Handle Cover	Plastic	-
18	Handle	Stainless Steel	AISI 430

DN	Inch	L	H	ød	S	S1	R	Kg
8	1/4	58.2	55	11.6	26.5	13.3	95	0.4
10	3/8	58.2	55	12.7	26.5	13.3	95	0.4
15	1/2	62	60	15	30.5	15.8	95	0.5
20	3/4	76	63	20	33	18.3	110	0.7
25	1	85	79	25	39.5	21.5	135	1.1
32	1 1/4	100	86	32	43.5	23	135	1.6
40	1 1/2	115	94	38	52	25	165	2.4
50	2	132.2	103	50	62	23.1	165	3.4
65	2 1/2	165	133	65	77	41.2	285	6.9
80	3	183	144	80	90	39.7	285	11.7
100	4	231.4	177	100	110	47.1	295	22.2



BALL VALVE

3-PC., FULL BORE, BUTT WELD ENDS

440565
1200WOG/
1000WOG

DESCRIPTION: Three piece, full bore, cast steel body ball valve with AISI 304 ball and PTFE seat ring. Butt weld ends.

APPLICATION: Start/stop flow of: Compressed air, steam, gases and liquids. Typically also used for drain and vent purposes.

STANDARD & DESIGN:

- Design Code: -
- Inspection Std.: -
- End Std.: -
- Face to Face Std.: -
- Top Flange: ISO 5211(DN8-DN100)
- Pressure rating: 1200WOG(DN8-DN40)
1000WOG(DN50-DN100)

VARIATIONS: Various actuators.
Other dimensions and materials on request.

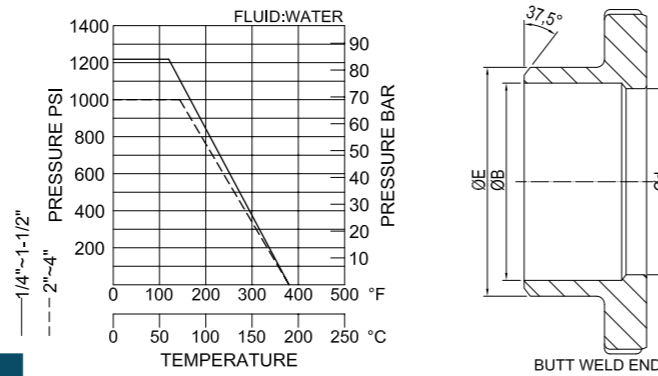
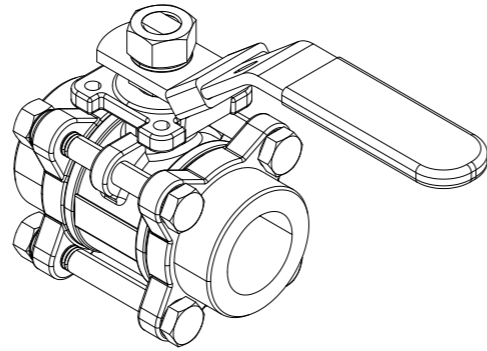

No	Part	Material	Code
1	Body	Cast Steel	ASTM-A216-WCB
2	Bonnet	Cast Steel	ASTM-A216-WCB
3	Ball	Stainless Steel	ASTM-A351-CF8
4	Ball Seat	PTFE	-
5	Stem	Stainless Steel	AISI 316
6	Joint Gasket	PTFE	-
7	Thrust Washer	PTFE	-
8	Stem Packing	PTFE	-
9	Gland Nut	Stainless Steel	AISI 304
10	Stem Washer	Stainless Steel	AISI 304
11	Stem Nut	Stainless Steel	AISI 304
12	Lock Device	Stainless Steel	AISI 304
13	Bolt	Stainless Steel	AISI 304
14	Spring Washer	Stainless Steel	AISI 304
15	Hex Nut	Stainless Steel	AISI 304
16	Stop Pin	Stainless Steel	AISI 304
17	Handle Cover	Plastic	-
18	Handle	Stainless Steel	AISI 430

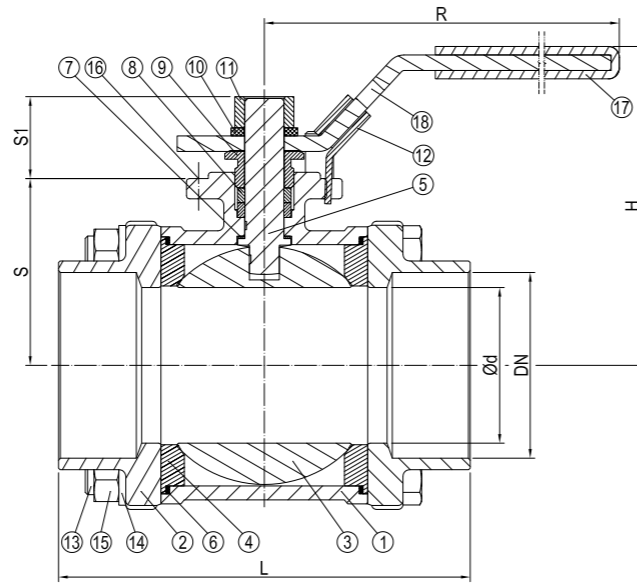

DN	Inch	L	H	ød	øB	øE	S	S1	R	Kg
8	1/4	58.2	55	11.6	12	18	26.5	13.3	95	0.4
10	3/8	58.2	55	12.7	14	18	26.5	13.3	95	0.4
15	1/2	62	60	15	17.1	22	30.5	15.8	95	0.5
20	3/4	76	63	20	22.5	27.5	33	18.3	110	0.7
25	1	85	79	25	28	33.5	39.5	21.5	135	1.1
32	1 1/4	100	86	32	33.5	44	43.5	23	135	1.6
40	1 1/2	115	94	38	43	50	52	25	165	2.4
50	2	132.2	103	50	53	61.5	62	23.1	165	3.4
65	2 1/2	165	133	65	65	76	77	41.2	285	6.9
80	3	183	144	80	80	92	90	39.7	285	11.7
100	4	231.4	177	100	100	115	110	47.1	295	22.2



BALL VALVE

3-PC., FULL BORE, BUTT WELD ENDS

440595
1200WOG/
1000WOG

DESCRIPTION: Three piece, full bore, AISI 316 body ball valve with AISI 316 ball and PTFE seat ring. Butt weld end.

APPLICATION: Start/stop flow of: Compressed air, steam, gases and acidic media etc. Typically also used for drain and vent purposes.

STANDARD & DESIGN:

- Design Code: -
- Inspection Std.: -
- End Std.: -
- Face to Face Std.: -
- Top Flange: ISO 5211(DN8-DN100)
- Pressure rating: 1200 WOG(DN8-DN40)
1000 WOG(DN50-DN100)

VARIATIONS: Various actuators.
Other dimensions and materials on request.

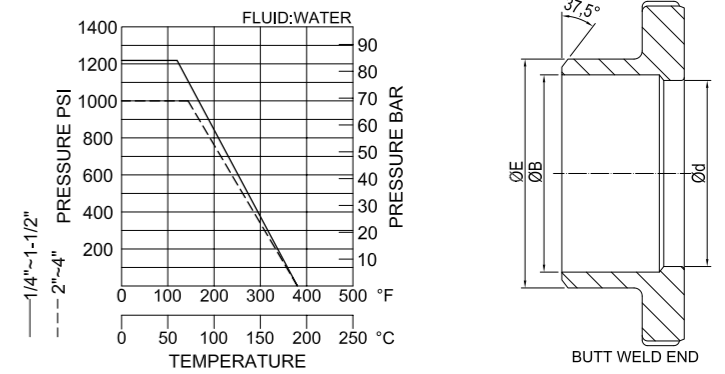
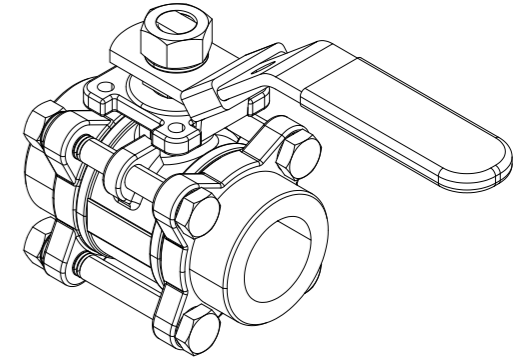

No	Part	Material	Code
1	Body	Stainless Steel	ASTM-A351-CF8M
2	Bonnet	Stainless Steel	ASTM-A351-CF8M
3	Ball	Stainless Steel	ASTM-A351-CF8M
4	Ball Seat	PTFE	-
5	Stem	Stainless Steel	AISI 316
6	Joint Gasket	PTFE	-
7	Thrust Washer	PTFE	-
8	Stem Packing	PTFE	-
9	Gland Nut	Stainless Steel	AISI 304
10	Stem Washer	Stainless Steel	AISI 304
11	Stem Nut	Stainless Steel	AISI 304
12	Lock Device	Stainless Steel	AISI 304
13	Bolt	Stainless Steel	AISI 304
14	Spring Washer	Stainless Steel	AISI 304
15	Hex Nut	Stainless Steel	AISI 304
16	Stop Pin	Stainless Steel	AISI 304
17	Handle Cover	Plastic	-
18	Handle	Stainless Steel	AISI 430

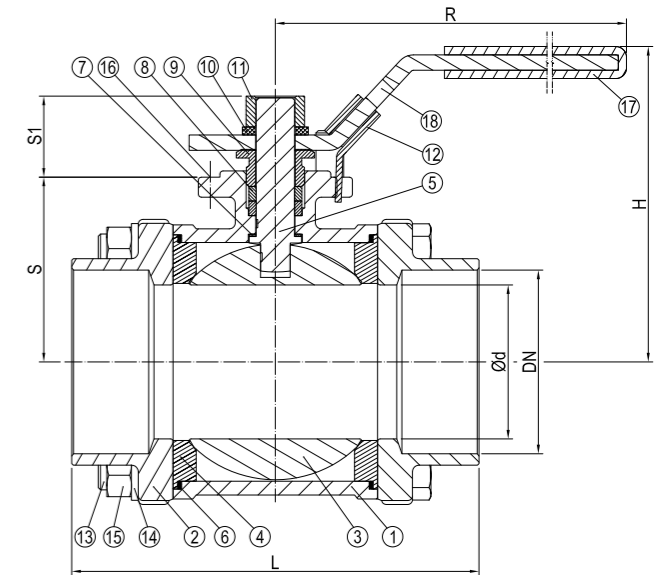

DN	Inch	L	H	ød	øB	øE	S	S1	R	Kg
8	1/4	58.2	55	11.6	12	18	26.5	13.3	95	0.4
10	3/8	58.2	55	12.7	14	18	26.5	13.3	95	0.4
15	1/2	62	60	15	17.1	22	30.5	15.8	95	0.5
20	3/4	76	63	20	22.5	27.5	33	18.3	110	0.7
25	1	85	79	25	28	33.5	39.5	21.5	135	1.1
32	1 1/4	100	86	32	33.5	44	43.5	23	135	1.6
40	1 1/2	115	94	38	43	50	52	25	165	2.4
50	2	132.2	103	50	53	61.5	62	23.1	165	3.4
65	2 1/2	165	133	65	65	76	77	41.2	285	6.9
80	3	183	144	80	80	92	90	39.7	285	11.7
100	4	231.4	177	100	100	115	110	47.1	295	22.2



BALL VALVE

3-PC., FULL BORE, LONG BUTT WELD ENDS

440695
1200WOG/
1000WOG

DESCRIPTION: Three piece, full bore, AISI 316 equivalent body ball valve with AISI 316 ball and PTFE seat ring. Long butt weld end.

APPLICATION: Start/stop flow of: Compressed air, steam, gases and acidic media etc. Typically also used for drain and vent purposes.

STANDARD & DESIGN:

- Design Code: -
- Inspection Std.: -
- End Std.: -
- Face to Face Std.: -
- Top Flange: ISO 5211(DN8-DN100)
- Pressure rating: 1200 WOG(DN8-DN40)
1000 WOG(DN50-DN100)

VARIATIONS: Various actuators.
Other dimensions and materials on request.

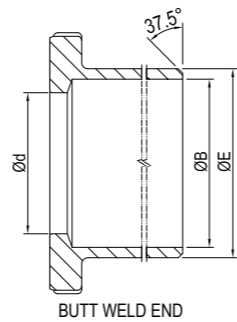
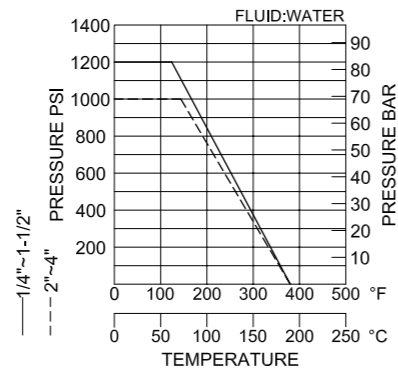
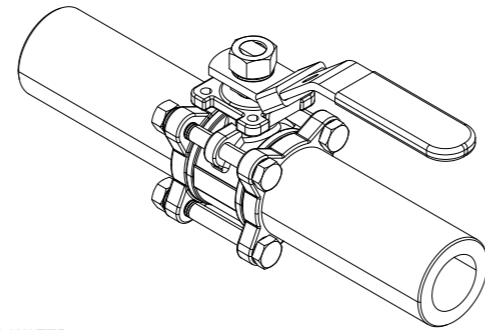

No	Part	Material	Code
1	Body	Stainless Steel	ASTM-A351-CF8M
2	Cap	Stainless Steel	ASTM-A351-CF8M
3	Ball	Stainless Steel	ASTM-A351-CF8M
4	Ball Seat	PTFE	-
5	Stem	Stainless Steel	AISI 316
6	Joint Gasket	PTFE	-
7	Thrust Washer	PTFE	-
8	Stem Packing	PTFE	-
9	Gland Nut	Stainless Steel	AISI 304
10	Stem Washer	Stainless Steel	AISI 304
11	Stem Nut	Stainless Steel	AISI 304
12	Lock Device	Stainless Steel	AISI 304
13	Bolt	Stainless Steel	AISI 304
14	Spring Washer	Stainless Steel	AISI 304
15	Hex Nut	Stainless Steel	AISI 304
16	Stop Pin	Stainless Steel	AISI 304
17	Handle Cover	Plastic	-
18	Handle	Stainless Steel	AISI 304

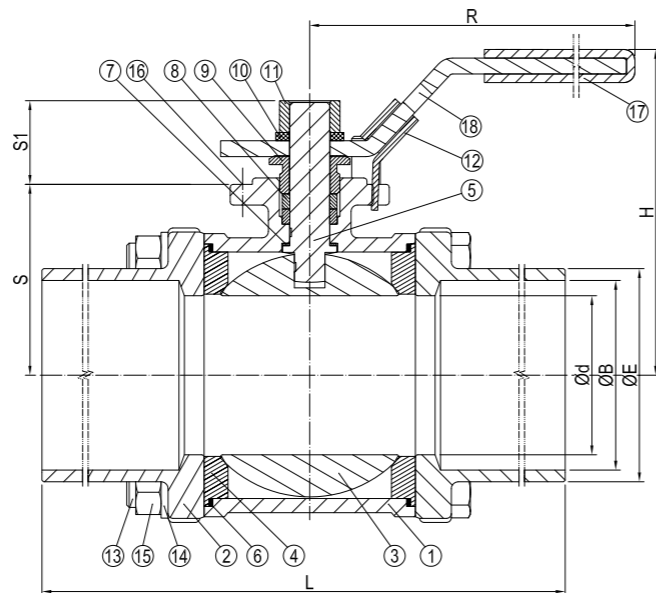

DN	Inch	L	H	Ød	ØB	ØE	S	S1	R	Kg
8	1/4	225	55	11.6	12	18	26.5	13.3	95	0.6
10	3/8	225	55	12.7	14	18	26.5	13.3	95	0.7
15	1/2	225	60	15	17.1	22	30.5	15.8	95	0.7
20	3/4	225	63	20	22.5	27.5	33	18.3	110	0.9
25	1	245	79	25	28	33.5	39.5	21.5	135	1.4
32	1 1/4	255	86	32	33.5	44	43.5	23	135	2.5
40	1 1/2	260	94	38	43	50	52	25	165	2.9
50	2	275	103	50.8	53	61.5	62	23.1	165	4.3
65	2 1/2	334	133	65	65	76	77	41.2	285	8.6
80	3	354	144	80	80	92	90	39.7	285	13.7
100	4	365	177	100	100	115	110	47.1	295	23.8



BALL VALVE

3-PC., FULL BORE, THREADED ENDS

440096
2000WOG/
1500WOG/
1000WOG

DESCRIPTION: Three piece, full bore, AISI 316 body ball valve with AISI 316 ball and carbon filled PTFE seat ring. Female BSPP threaded ends.

APPLICATION: Start/stop flow of: Compressed air, steam, gases and acidic media etc. Typically also used for drain and vent purposes.

STANDARD & DESIGN:

- Design Code: ASME B16.34
- Inspection Std.: API 598
- End Std.: ISO 228
- Face to Face Std.: -
- Top Flange: ISO 5211(DN8-DN100)
- Pressure rating: 2000 WOG(DN8-DN25)
1500 WOG(DN32-DN50)
1000 WOG(DN65-DN100)

VARIATIONS: Available as Fire safe version API 607 6th Edition Design. Various actuators. Other dimensions and materials on request.

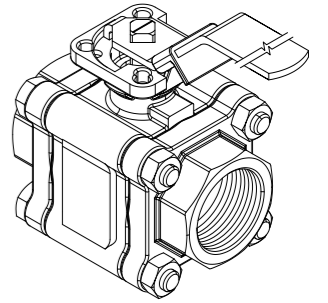
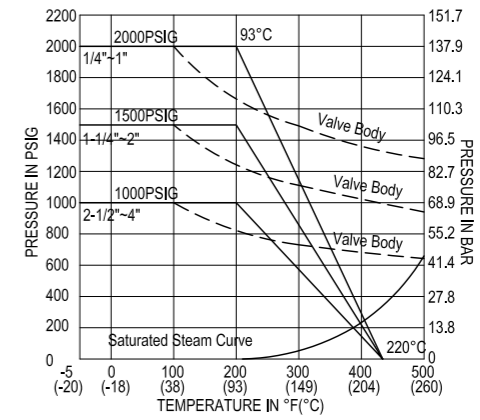

No	Part	Material	Code
1	Body	Stainless Steel	CF8M
2	End Cap	Stainless Steel	CF8M
3	Gland	Stainless Steel	SS304
4	Ball	Stainless Steel	SS316
5	Seat	RTFE	-
6	Stem	Stainless Steel	SS316
7	Joint Gasket	PTFE	-
8	Stem Seal	RPTFE	-
9	Stem Packing	PTFE	-
10	Stem Packing	PTFE +25% Glass Fibre	-
11	Belleville Washer	Stainless Steel	SS301
12	Stem Nut	Stainless Steel	SS304
13	Lock Saddle	Stainless Steel	SS304
14	Stem Washer	Stainless Steel	SS304
15	Locking Device	Stainless Steel	SS304
16	Bolt	Stainless Steel	SS304
17	Bolt Nut	Stainless Steel	SS304
18	O-Ring	VITON	-
19	Antistatic Device	Stainless Steel	SS316
20	Bolt	Stainless Steel	SS304
21	Handle Screw	Stainless Steel	SS304
22	Seat Ring	Stainless Steel	CF8M
23	Handle Sleeve	VINYL	-
24	Handle	Stainless Steel	SS304
25	Handle-A	Stainless Steel	SS304
26	Handle-B	Stainless Steel	SS304

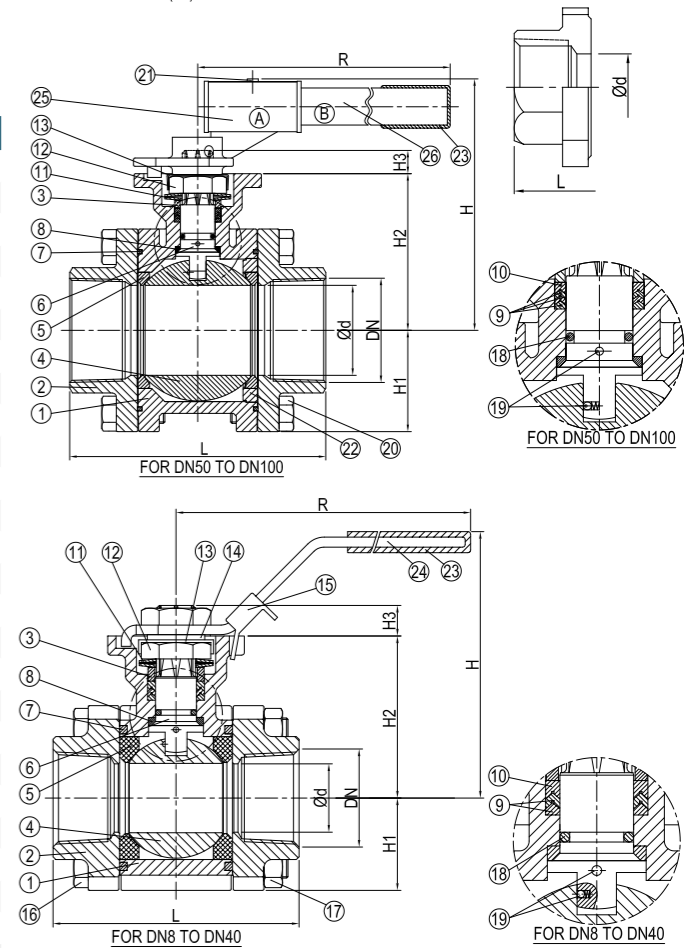

DN	Inch	L	H	H1	H2	H3	Ød	R	Kg
8	1/4	75	60	25.6	42.6	7.6	11.6	148	0.9
10	3/8	75	60	25.6	42.6	7.6	12.7	148	0.9
15	1/2	72.5	75	25.6	42.6	7.6	15	148	0.8
20	3/4	85.4	82	30.7	46.85	8.6	20	148	1.3
25	1	105.3	99	33.8	59.3	10.4	25	193	2.2
32	1 1/4	111	101	38.6	62.6	10.4	32	193	2.9
40	1 1/2	127.3	129	43.3	79	13.4	38	233	4.5
50	2	145	137	61.4	92.7	13.4	50	233	8.0
65	2 1/2	185	176	73.2	113.2	16.8	65	335	14.2
80	3	205	185	84.3	123.2	16.8	80	405	18.6
100	4	240	192	107	133.7	16.8	100	405	30.3



BALL VALVE

3-PC., FULL BORE, BUTT WELD ENDS

440596
2000WOG/
1500WOG/
1000WOG

DESCRIPTION: Three piece, full bore, AISI 316 body ball valve with AISI 316 ball and carbon filled PTFE seat ring. Butt weld ends.

APPLICATION: Start/stop flow of: Compressed air, steam, gases and acidic media etc. Typically also used for drain and vent purposes.

STANDARD & DESIGN:

Design Code:	ASME B16.34
Inspection Std.:	API 598
End Std.:	ASME B16.25
Face to Face Std.:	-
Top Flange:	ISO 5211(DN8-DN100)
Pressure rating:	2000 WOG(DN8-DN25) 1500 WOG(DN32-DN50) 1000 WOG(DN65-DN100)

VARIATIONS: Available as Fire safe version API 607 6th Edition Design. Various actuators. Other dimensions and materials on request.

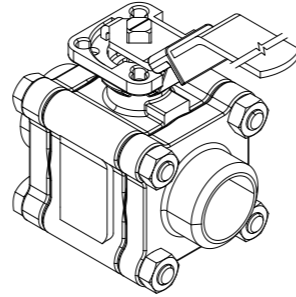
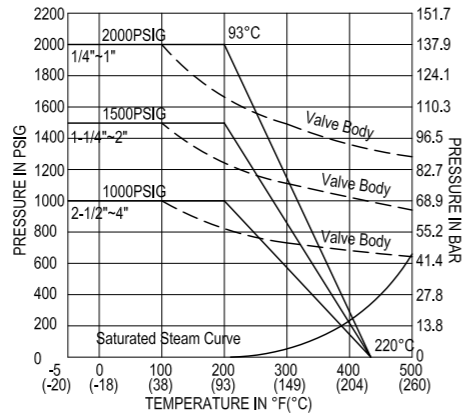

No	Part	Material	Code
1	Body	Stainless Steel	CF8M
2	End Cap	Stainless Steel	CF8M
3	Gland	Stainless Steel	SS304
4	Ball	Stainless Steel	SS316
5	Seat	RTFE	-
6	Stem	Stainless Steel	SS316
7	Joint Gasket	PTFE	-
8	Stem Seal	RPTFE	-
9	Stem Packing	PTFE	-
10	Stem Packing	PTFE +25% Glass Fibre	-
11	Belleville Washer	Stainless Steel	SS301
12	Stem Nut	Stainless Steel	SS304
13	Lock Saddle	Stainless Steel	SS304
14	Stem Washer	Stainless Steel	SS304
15	Locking Device	Stainless Steel	SS304
16	Bolt	Stainless Steel	SS304
17	Bolt Nut	Stainless Steel	SS304
18	O-Ring	VITON	-
19	Antistatic Device	Stainless Steel	SS316
20	Bolt	Stainless Steel	SS304
21	Handle Screw	Stainless Steel	SS304
22	Seat Ring	Stainless Steel	CF8M
23	Handle Sleeve	VINYL	-
24	Handle	Stainless Steel	SS304
25	Handle-A	Stainless Steel	SS304
26	Handle-B	Stainless Steel	SS304

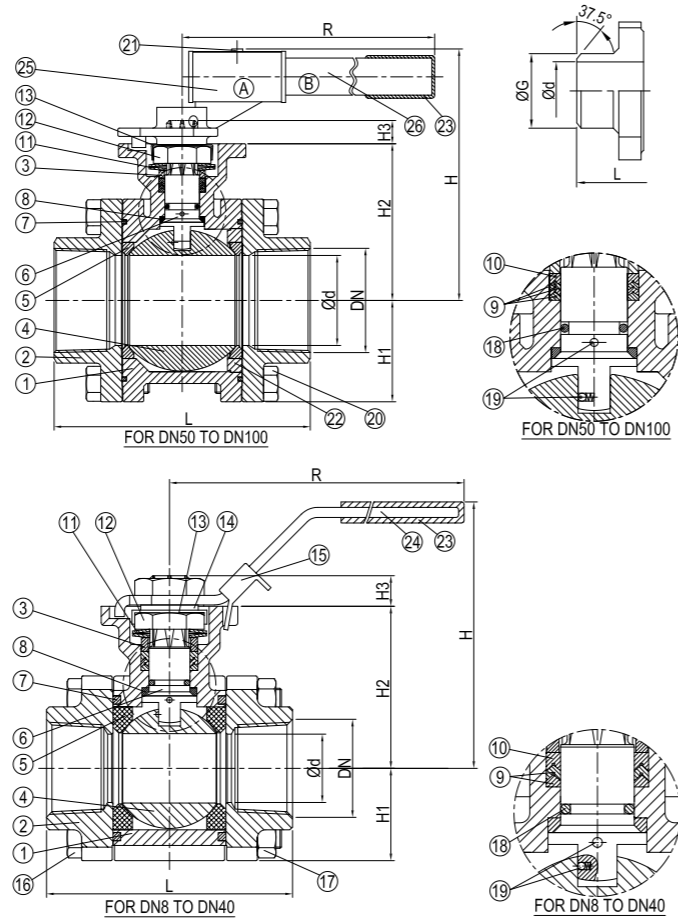

DN	Inch	L	øG	H	H1	H2	H3	ød	R	Kg
8	1/4	75	21.7	60	25.6	42.6	7.6	11.6	148	0.9
10	3/8	75	21.7	60	25.6	42.6	7.6	12.7	148	0.9
15	1/2	75	21.7	75	25.6	42.6	7.6	15	148	0.8
20	3/4	90	27.2	82	30.7	46.85	8.6	20	148	1.3
25	1	110	34	99	33.8	59.3	10.4	25	193	2.2
32	1 1/4	115	42.7	101	38.6	62.6	10.4	32	193	2.9
40	1 1/2	130	48.6	129	43.3	79	13.4	38	233	4.5
50	2	145	60.5	137	61.4	92.7	13.4	50	233	8.0
65	2 1/2	185	77.3	176	73.2	113.2	16.8	65	335	14.2
80	3	205	90	185	84.3	123.2	16.8	80	405	18.6
100	4	240	116	192	107	133.7	16.8	100	405	30.3



BALL VALVE

FULL BORE ,THREADED ENDS

442095
1000 WOG

DESCRIPTION: Two piece, full bore, AISI 316 body ball valve with AISI 316 ball and PTFE seat ring. Female BSPT alternatively NPT threaded ends.

APPLICATION: Start/stop flow of: Compressed air, steam, gases and acidic media etc. Typically also used for drain and vent purposes.

STANDARD & DESIGN:

Design Code:	BS EN 12516-2
Inspection Std.:	API 598
End Std.:	DIN2999
Pressure rating:	1000 WOG

VARIATIONS:

Other dimensions and materials on request.

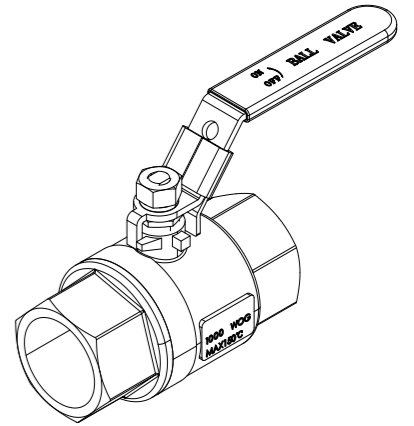
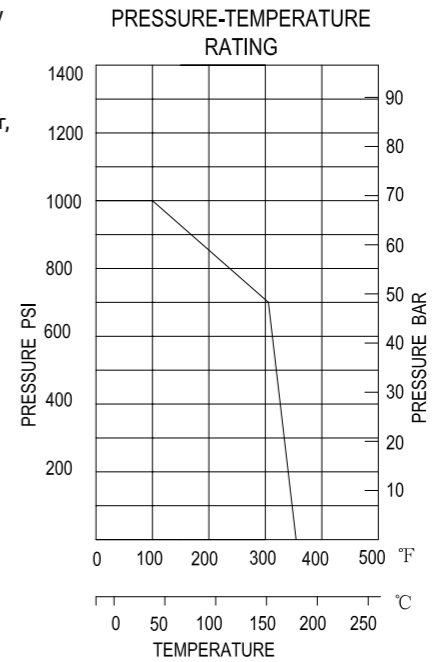

No	Part	Material	Code
1	Body	Stainless Steel	CF8M
2	Ball	Stainless Steel	CF8M
3	Ball Seat	PTFE	-
4	Stem	Stainless Steel	316
5	Cap	Stainless Steel	CF8M
6	Joint Gasket	PTFE	-
7	Thrust Washer	PTFE	-
8	Stem Packing	PTFE	-
9	Gland Nut	Stainless Steel	304
10	Spring Washer	Stainless Steel	304
11	Stem Nut	Stainless Steel	304
12	Lock Device	Stainless Steel	304
13	Handle Cover	Plastic	-
14	Handle	Stainless Steel	304

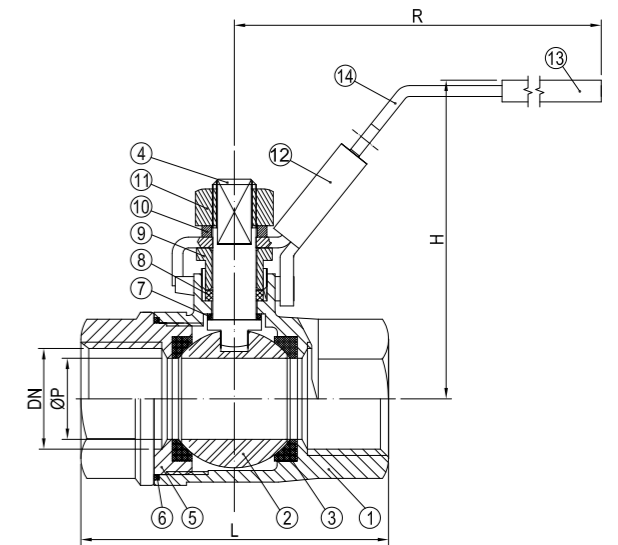

DN	Inch	L	H	R	øP	Kg
8	1/4	54	54	110	9.2	0.2
10	3/8	54	55	110	12.8	0.2
15	1/2	57	58	115	15	0.3
20	3/4	68	61	115	20	0.5
25	1	80	77	128	25	0.8
32	1 1/4	91	81	128	32	1.0
40	1 1/2	103	90	155	38	1.5
50	2	124	108	155	50	2.7
65	2 1/2	160	132	230	65	4.9
80	3	185	145	230	80	7.2
100	4	224.5	185	335	100	12.7



BALL VALVE

FULL BORE, THREADED ENDS

442095-403
1200WOG/
1000WOG

DESCRIPTION: Two piece, full bore, AISI 316 body ball valve with AISI 316 ball and PTFE seat ring. With direct mounting pad. BSPP female thread.

APPLICATION: Start/stop flow of: Compressed air, steam, gases and acidic media etc. Typically also used for drain and vent purposes.

STANDARD & DESIGN:

Design Code: -
 Inspection Std.: -
 End Std.: ISO 228
 Face to Face Std.: -
 Top Flange: ISO 5211 Direct Mounting Pad (DN8-DN80)
 Pressure rating: 1200WOG(DN8-DN40)
 1000WOG(DN50-DN80)

VARIATIONS: Various actuators.
 Other dimensions and materials on request.
 Threaded ends ANSI B2.1, NPT.

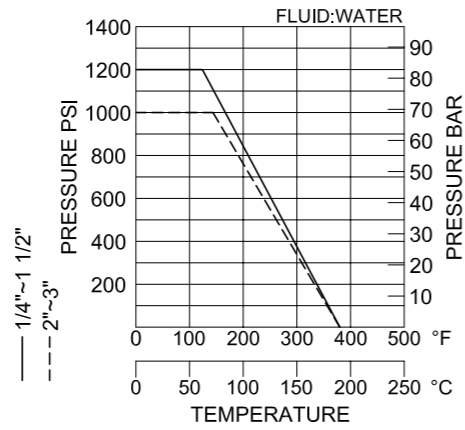
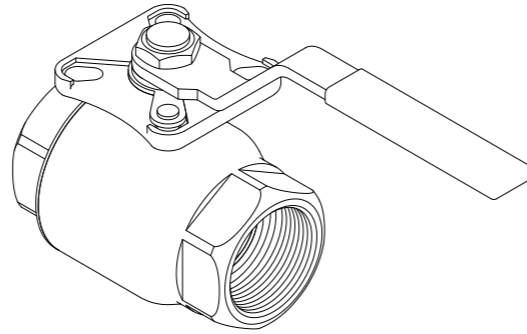

No	Part	Material	Code
1	Body	Stainless Steel	ASTM-A351-CF8M
2	Cap	Stainless Steel	ASTM-A351-CF8M
3	Ball	Stainless Steel	ASTM-A351-CF8M
4	Ball Seat	PTFE	-
5	Stem	Stainless Steel	AISI 316
6	Joint Gasket	PTFE	-
7	Thrust Washer	PTFE	-
8	O-Ring	VITON	-
9	Stem Packing	PTFE	-
10	Stem Ring	Stainless Steel	AISI 304
11	Belleville Washer	Stainless Steel	AISI 304
12	Stem Nut	Stainless Steel	AISI 304
13	Stopper	Stainless Steel	AISI 304
14	Stopper Pin	Stainless Steel	AISI 304
15	Lock Washer	Stainless Steel	AISI 304
16	Handle Cover	Plastic	-
17	Handle	Stainless Steel	AISI 430

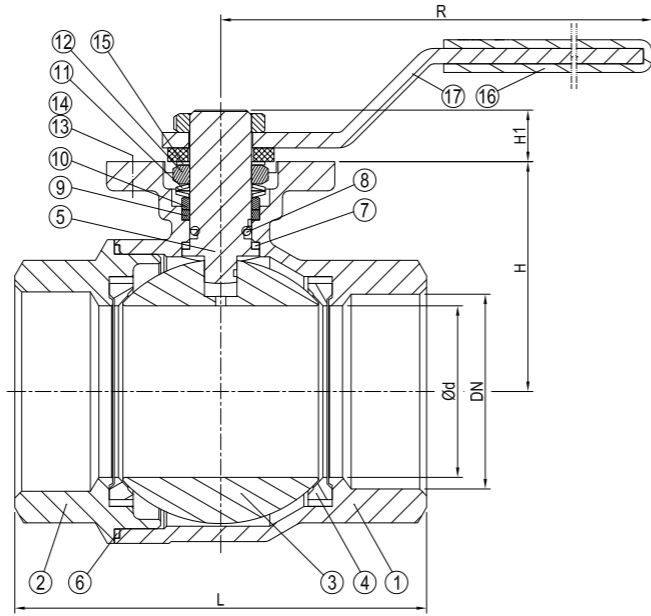

DN	Inch	L	od	H	H1	R	Kg
8	1/4	49.6	11	36	10	110	0.3
10	3/8	49.6	12.7	36	10	110	0.3
15	1/2	55	15	38	10	110	0.3
20	3/4	75.5	20	41.7	12	136	0.6
25	1	82.5	25	44.4	12	136	0.8
32	1 1/4	90.8	32	54	16.5	158	1.4
40	1 1/2	103	40	59.5	16.5	203	1.9
50	2	120	50	67	16.5	203	2.8
65	2 1/2	155	65	101.5	24.5	322.5	7.0
80	3	182	80	112.5	24.5	322.5	10.3



BALL VALVE

FULL BORE, THREADED ENDS

442013
PN30/PN25/
PN20

DESCRIPTION: Two piece, full bore, hard chromed brass body ball valve with hard chromed brass ball and PTFE seat ring. Female BSPP threaded ends.

APPLICATION: Start/stop flow of: Compressed air, gases and liquids. Typically also used for drain and vent purposes.

STANDARD & DESIGN:

Design Code: -
 Inspection Std.: -
 End Std.: UNI ISO 228
 Face to Face Std.: -
 Pressure rating: PN30(DN10-DN20)
 PN25(DN25-DN50)
 PN20(DN65-DN100)
 Temperature Range: -20°C to 120°C

VARIATIONS: Other dimensions and materials on request.

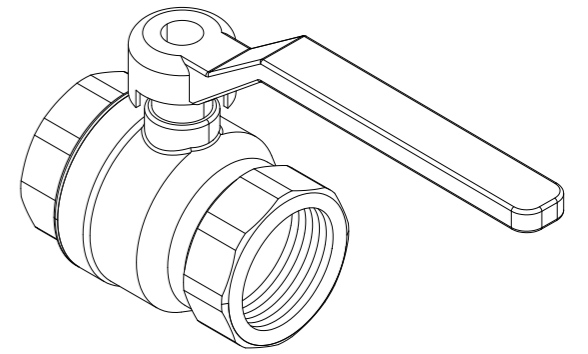

No	Part	Material	Code
1	Body (<=DN50)	Brass	PCuZn40Pb2
	(>=DN65)	Brass	G-CuZn38Pb2 Nickel plated
2	Gland*	Brass	PCuZn35Pb2
3	Ball	Brass	PCuZn40Pb2 Chromed
4	Ball Seat	PTFE	-
5	Stem	Brass	PCuZn35Pb2
6	Coupling Sleeve	Brass	PCuZn40Pb2
7	O-Ring	NBR	-
8	O-Ring*	NBR	-
9	Screw	Iron	Fe 42
10	Gland Packing*	PTFE	-
11	Handle (<=DN65)	Iron	Fe P04
	(>=DN80)	Aluminium	Al

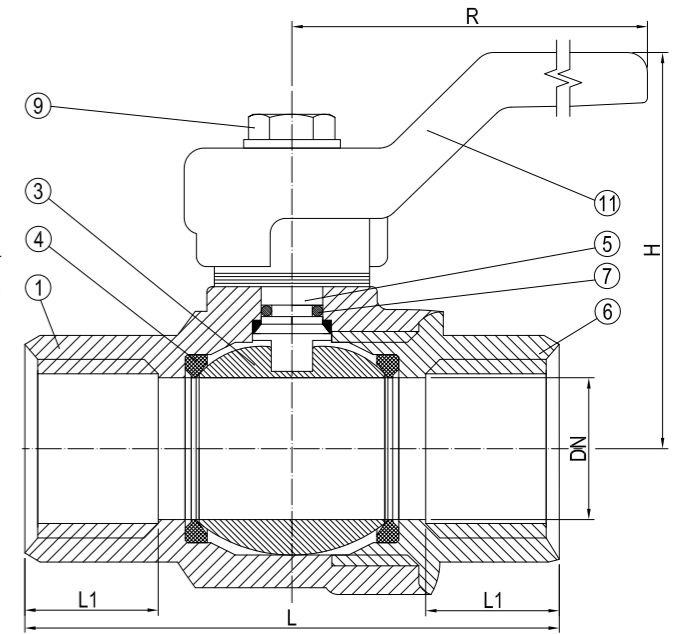

* NOT SHOWN IN DIMENSIONAL VIEW ABOVE,
 ONLY APPLICABLE FOR SIZES DN65-DN100

DN	Inch	L	L1	H	R	Kg
10	3/8	46	11	40	85	0.1
15	1/2	50	11	45	90	0.2
20	3/4	60	12	50	90	0.3
25	1	68	14	60	90	0.4
32	1 1/4	82	15	70	125	0.7
40	1 1/2	92	15	75	125	0.9
50	2	108	18	90	160	1.5
65	2 1/2	134	20	115	210	3.0
80	3	156	22	130	270	5.1
100	4	184	25	160	310	8.0



BALL VALVE

FULL BORE, THREADED ENDS

442113
PN30/PN25/PN20

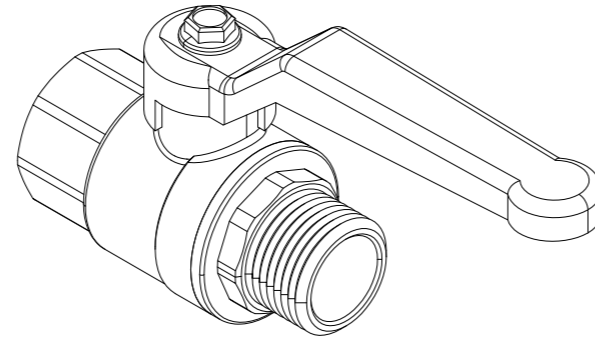

DESCRIPTION: Two piece, full bore, hard chromed brass body ball valve with hard chromed brass ball and PTFE seat ring. BSPP female/male threaded ends.

APPLICATION: Start/stop flow of: Compressed air, gases and liquids. Typically also used for drain and vent purposes.

STANDARD & DESIGN:

Design Code: -
 Inspection Std.: -
 End Std.: DIN 2999
 Face to Face Std.: -
 Pressure rating: PN30(DN10-DN20)
 PN25(DN25-DN50)
 PN20(DN65-DN100)
 Temperature Range: -20°C to 120°C

VARIATIONS: Other dimensions and materials on request.

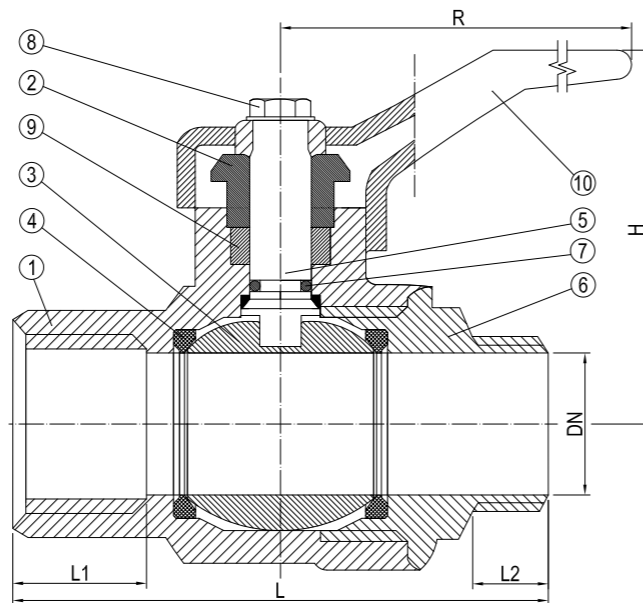

No	Part	Material	Code
1	Body	Brass	PCuZn40Pb2
2	Gland (>=DN15)	Brass	PCuZn35Pb2
3	Ball	Brass	PCuZn40Pb2 Chromed
4	Ball Seat	PTFE	-
5	Stem	Brass	PCuZn35Pb2
6	Coupling Sleeve	Brass	PCuZn40Pb2
7	O-Ring	NBR	-
8	Screw	Iron	Fe 42
9	Gland Packing (>=DN15)	PTFE	-
10	Handle	Iron	Fe P04

DN	Inch	L	L1	L2	H	R	Kg
8	1/4	49	12	10	40	85	0.1
10	3/8	49	12	11	40	85	0.1
15	1/2	61	15	12	45	90	0.2
20	3/4	68	16.5	13	50	90	0.3
25	1	80	19	15	65	125	0.6
32	1 1/4	95	21.5	16	72	125	0.9
40	1 1/2	105	21.5	16	80	160	1.3
50	2	128	26	20	85	160	2.0



BALL VALVE

FULL BORE, THREADED ENDS

443024
PN32/PN25

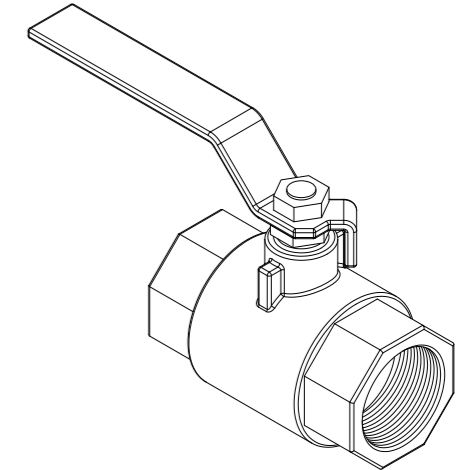

DESCRIPTION: Three piece, full bore, Rg5 body ball valve with hard chromed brass ball and PTFE seat ring. Female BSPP threaded ends.

APPLICATION: Start/stop flow of: Compressed air, steam, gases and liquids. Typically also used for drain and vent purposes.

STANDARD & DESIGN:

Design Code: -
 Inspection Std.: -
 End Std.: ISO 228
 Face to Face Std.: -
 Pressure rating: PN32(DN8-DN50)
 PN25(DN65-DN100)
 Temperature Range: -10°C to 120°C

VARIATIONS: Other dimensions and materials on request.

No	Part	Material	Code
1	Body	Bronze	CC491K
2	Gland	Brass	CW617N
3	Ball	Brass Chrome-Plated	CW617N
4	Stem	Brass	CW617N
5	Seal	PTFE	-
6	End Connection	Bronze	CC491K
7	Gland Packing	PTFE	-
8	Nut	Galvanised Iron	-
9	Lever	Galvanised Iron & PVC Coated	-

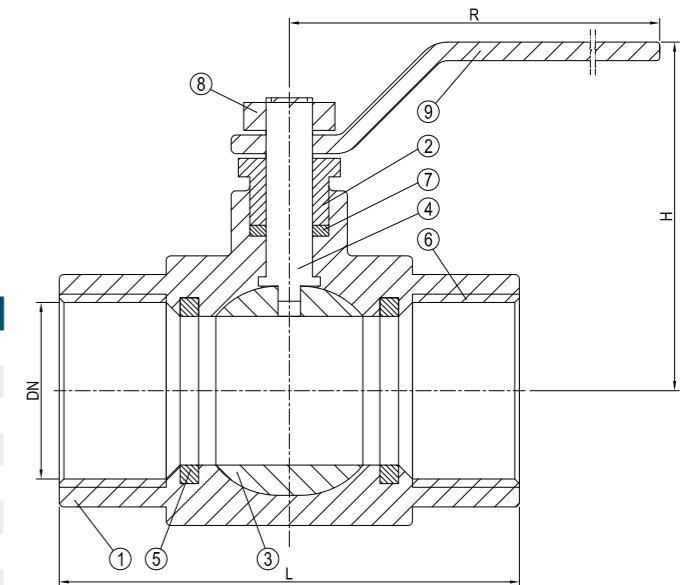

DN	Inch	L	H	R
8	1/4	51	47.5	85
10	3/8	51	47.5	85
15	1/2	62	45	85
20	3/4	70	57.5	104
25	1	85	57.5	104
32	1 1/4	99	75	122
40	1 1/2	110	77.5	122
50	2	134	93	153
65	2 1/2	142	119.5	200
80	3	178	134	280
100	4	210	153.5	280



BALL VALVE

3-PC., FULL BORE FLANGED ENDS

440194
PN40

DESCRIPTION: Three piece, full bore, AISI 316 equivalent body ball valve with AISI 316 ball and PTFE seat ring. Raised face flanges.

APPLICATION: Start/stop flow of: Compressed air, steam, gases and acidic media etc. Typically also used for drain and vent purposes.

STANDARD & DESIGN:

Design Code: -
 Inspection Std.: -
 End Std.: -
 Face to Face Std.: DIN3202-F1
 Flanges drilled: PN40(DN15-DN100)
 Pressure rating: PN40(DN15-DN100)

VARIATIONS: Various actuators.

Other dimensions and materials on request.

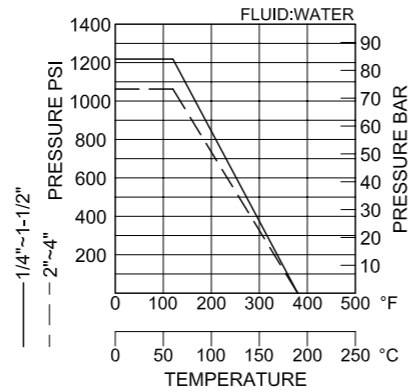
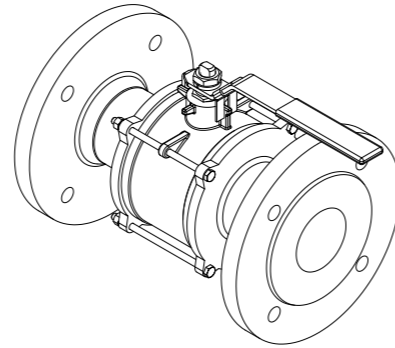

No	Part	Material	Code
1	Body	Stainless Steel	ASTM-A351-CF8M
2	Bonnet	Stainless Steel	ASTM-A351-CF8M
3	Ball	Stainless Steel	ASTM-A351-CF8M
4	Ball Seat	PTFE	-
5	Stem	Stainless Steel	AISI 316
6	Joint Gasket	PTFE	-
7	Thrust Washer	PTFE	-
8	Stem Packing	PTFE	-
9	Gland Nut	Stainless Steel	AISI 304
10	Stem Washer	Stainless Steel	AISI 304
11	Stem Nut	Stainless Steel	AISI 304
12	Lock Device	Stainless Steel	AISI 304
13	Bolt	Stainless Steel	AISI 304
14	Spring Washer	Stainless Steel	AISI 304
15	Hex Nut	Stainless Steel	AISI 304
16	Handle Cover	Plastic	-
17	Handle	Stainless Steel	AISI 430

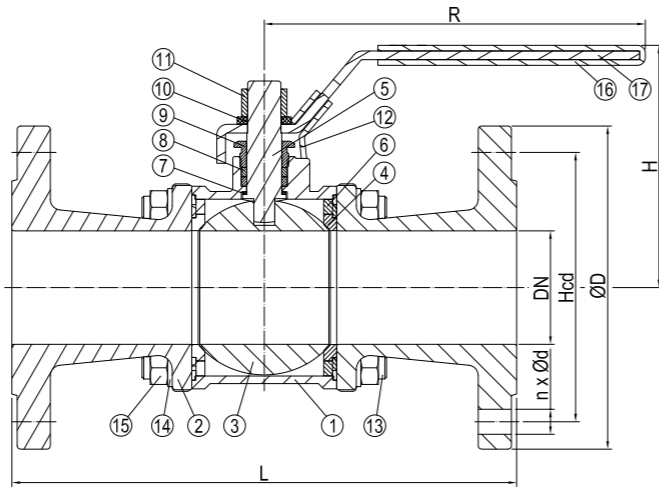

DN	n x ød	Hcd	øD	L	H	R	Kg
15	4x14	65	95	130	73.5	130	2.5
20	4x14	75	105	150	77.5	155	3.5
25	4x14	85	115	160	93.5	173	4.7
32	4x18	100	140	180	99	173	7.0
40	4x18	110	150	200	108.5	185	8.4
50	4x18	125	165	230	117	185	11.7
65	8x18	145	185	290	127	215	16.9
80	8x18	160	200	305	136	215	27.2
100	8x22	190	235	355	191	325	39.0



BALL VALVE

2PC., FULL BORE, FLANGED ENDS

445102
PN16

DESCRIPTION: Two piece, full bore, nodular cast iron body ball valve with hard chromed brass ball and PTFE seat ring. Raised face flanged.

APPLICATION:

Water, Conditioning, Gas, Heating, Industry, Fire fighting. Start/stop flow of: Compressed air, gases and liquids. Typically also used for drain and vent purposes.

STANDARD & DESIGN:

Design Code: EN 1983, EN13445, ISO5211
 Inspection Std.: EN 12266 cat. A (ISO 5208 cat. A)
 End Std.: EN 1092
 Face to Face Std.: EN 558/1 (ISO 5752)
 Flanges drilled: PN16 (DN15-DN150)
 Top Flange: ISO 5211 (DN15-DN150)
 Pressure rating: PN16 (DN15-DN150)

VARIATIONS: Available with stainless steel (AISI 304) ball and stem.

Available with end std. ANSI B16.5 #150. Various actuators. Other dimensions and materials on request.

Pressure/temperature chart

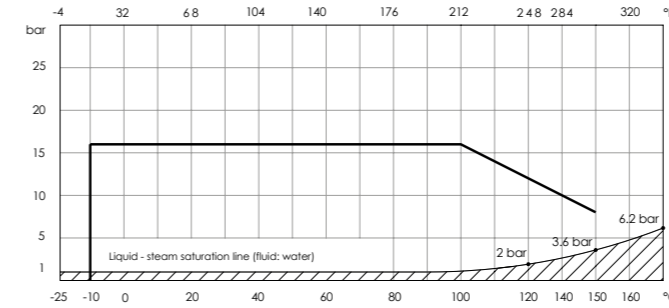

RANGE NOT SUITABLE FOR STEAM. DO NOT use when temperature and pressure are below the liquid-steam saturation line (hatched area)

No	Part	Material	Code
1	Body	Nodular Cast Iron	EN GJS 400-15
2	Ball	Brass	CuZn40Pb2
3	Ball Seat	PTFE	-
4	Stem	Brass	CuZn40Pb2
5	Flange	Cast Iron	EN GJS 400-15
6	Sliding Washer	PTFE	-
7	Ring	Brass	CuZn40Pb2
8	O-Ring	NBR	-
9	Lever	Carbon Steel	-
10	Stop Plate	Galvanised Carbon Steel	-
11	Spring Washer	Galvanised Carbon Steel	-

DN	n x ød	øD	L	H	H2	R	øP	Kg
15	4x14	95	115	84	50.5	160	15	2.6
20	4x14	105	120	84	52	160	20	3.3
25	4x14	115	125	96	59	170	25	4.2
32	4x18	140	130	101	64	170	32	5.8
40	4x18	150	140	125	78.5	230	40	7.5
50	4x18	165	150	135	87	230	50	9.0
65	8x18	185	170	143	95	230	63	10.5
80	8x18	200	180	165	118	280	76	15.5
100	8x18	220	190	180	132.5	360	95	18.5
125	8x18	250	200	225	165	450	120	28.0
150	8x22	285	210	243	182.5	560	145	38.5

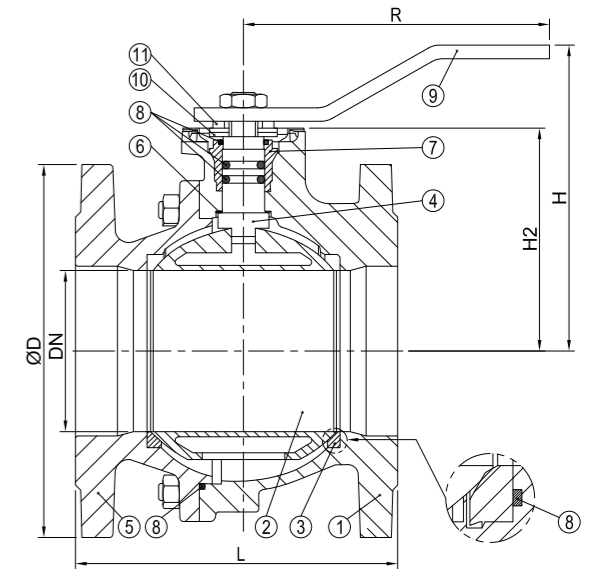
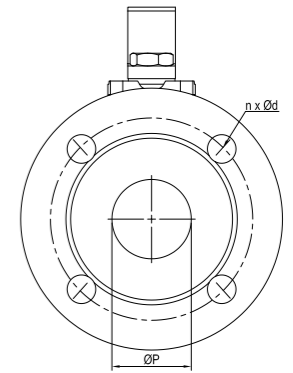
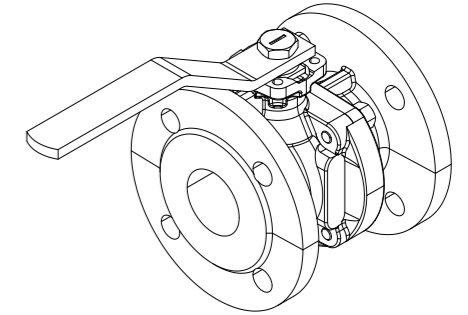



BALL VALVE

2PC., FULL BORE, FLANGED ENDS

445124/22-403
PN40/PN16

DESCRIPTION: Two piece, full bore, Rg5 body ball valve with AISI 316 ball and PTFE seat ring. Raised face flanged. With direct mounting pad.

APPLICATION: Start/stop flow of: Compressed air, gases and liquids. Typically also used for drain and vent purposes.

STANDARD & DESIGN:

Design Code: -
 Inspection Std.: -
 End Std.: -
 Face to Face Std.: DIN 3201 F4
 Flanges Drilled: PN40(DN15-DN50)
 PN16(DN65-DN100)
 Pressure rating: PN40(DN15-DN50)
 PN16(DN65-DN100)
 Top flange: ISO 5211 DMP (DN15-DN100)

VARIATIONS: Various actuators.

Hard chromed brass ball.

Other dimensions and materials on request.

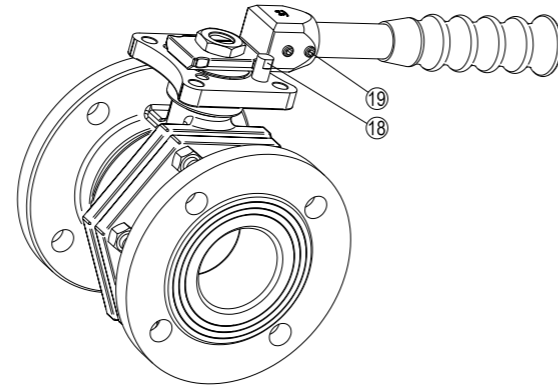

No	Part	Material	Code
1	Body	Bronze	CC 491K
2	Ball	Stainless Steel	EN 1.4404
3	Ball Seat	PTFE	-
4	Stem	Stainless Steel	EN 1.4404
5	Flange	Bronze	CC 491K
6	Body Gasket	PTFE	-
7	Stud	Stainless Steel	EN 1.4301
8	Nut	Stainless Steel	EN 1.4301
9	O-Ring	Viton	-
10	Stem Packing	PTFE	-
11	Gland Packing	PTFE	-
12	Gland Bush	Stainless Steel	EN 1.4301
13	Belleville Washer	Stainless Steel	EN 1.4310
14	Nut	Stainless Steel	EN 1.4301
15	Stop Washer	Stainless Steel	EN 1.4301
16	Handle Head	Stainless Steel	EN 1.4301
17	Nut	Stainless Steel	EN 1.4301
18	Stop Pin	Stainless Steel	EN 1.4301
19	Set Screw	Stainless Steel	EN 1.4301
20	Handle	Stainless Steel	EN 1.4301

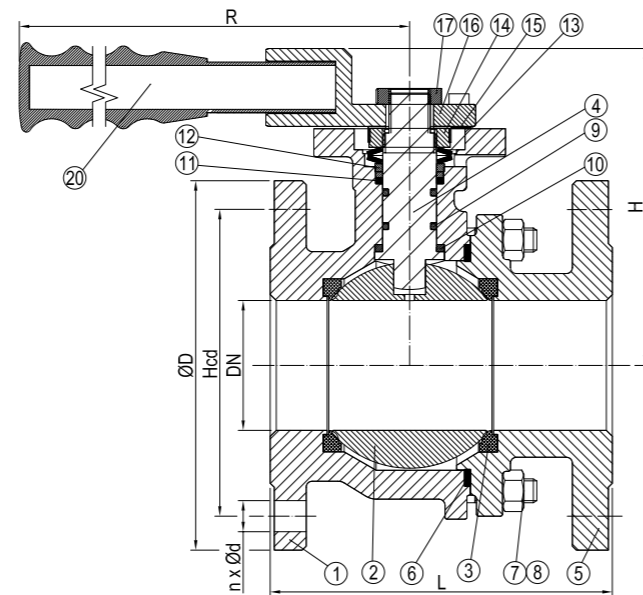

DN	n x ød	Hcd	øD	L	H	R	Kg
15	4x14	65	95	115	90	165	2.6
20	4x14	75	105	120	92	165	3.6
25	4x14	85	115	125	100	165	4.3
32	4x18	100	140	130	110	215	6.4
40	4x18	110	150	140	115	215	8.0
50	4x18	125	165	150	120	215	10.8
65	4x18	145	185	170	170	263	17.0
80	8x18	160	200	180	180	365	20.5
100	8x18	180	220	190	190	365	26.5



BALL VALVE

2-PC., FULL BORE, FLANGED ENDS

445162
PN16

DESCRIPTION: Two piece, full bore, cast steel body ball valve with AISI 304 ball and PTFE seat ring. Raised face flanged.

APPLICATION: Start/stop flow of: Compressed air, gases and liquids. Typically also used for drain and vent purposes.

STANDARD & DESIGN:

Design Code: ASME B16.34
 Inspection Std.: EN 12266-1
 End Std.: PN16 DIN 2633
 Face to Face Std.: DIN 3202-F4 / F5
 Top Flange: ISO 5211(DN15-DN300)
 Flanges drilled: PN16(DN15-DN300)
 Pressure rating: PN16(DN15-DN300)

VARIATIONS: With Direct Mounting Pad, Fire Safe version.

Various actuators.

Other dimensions and materials on request.

No	Part	Material	Code
1	Body	Cast Steel	1.0619
2	Cap	Cast Steel	1.0619
3	Gland	Stainless Steel	SUS304
4	Gland*	Stainless Steel	1.4308
5	Ball	Stainless Steel	1.4308
6	Seat	PTFE	-
7	Stem	Stainless Steel	SUS316
8	Bonnet Gasket	PTFE	-
9	Thrust Washer	PTFE	-
10	Packing	PTFE	-
11	Spring Washer	Stainless Steel	SUS304
12	Stem Nut	Stainless Steel	SUS304
13	Locking Device	Stainless Steel	SUS304
14	Bolt	Carbon Steel	-
15	Nut	Carbon Steel	-
16	Gland Bolt*	Carbon Steel	-
17	Stopper*	Stainless Steel	SUS304
18	Snap Ring*	Stainless Steel	SUS304
19	Handle Cover	Plastic Cover	-
20	Handle	Stainless Steel	SUS304

DN	n x ød	Hcd	øD	L	H	R	Kg
15	4x14	65	95	115	76	153	2.4
20	4x14	75	105	120	78	153	3.2
25	4x14	85	115	125	92	188	3.9
32	4x18	100	140	130	95	188	5.4
40	4x18	110	150	140	126	245	6.7
50	4x18	125	165	150	132	245	9.6
65	4x18	145	185	170	166	288	13.8
80	8x18	160	200	180	176	288	18.3
100	8x18	180	220	190	190	388	23.7
125	8x18	210	250	325	224	750	38.7
150	8x22	240	285	350	247	750	52.9
200	12x22	295	340	400	305	1000	91.1
250	12x26	355	405	450	327	1000	169.2
300	12x26	410	460	500	355	1000	-

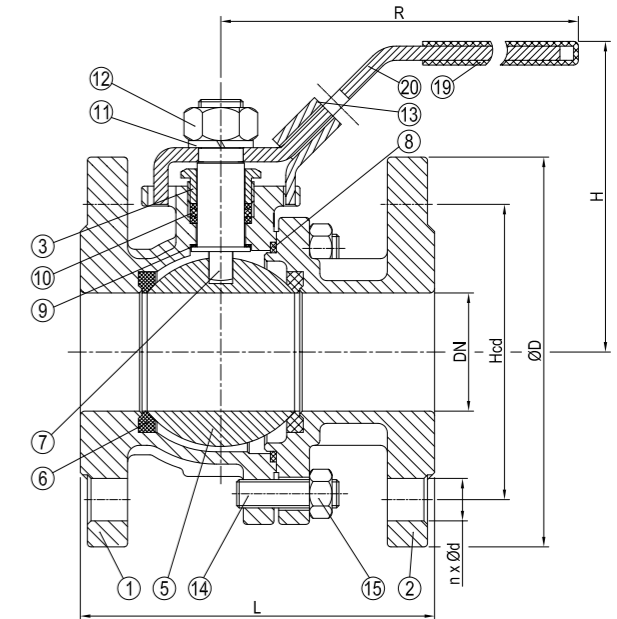
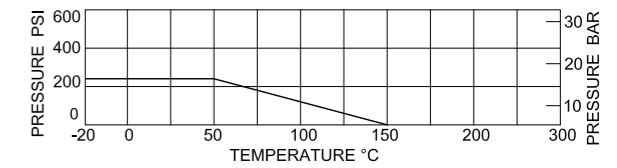
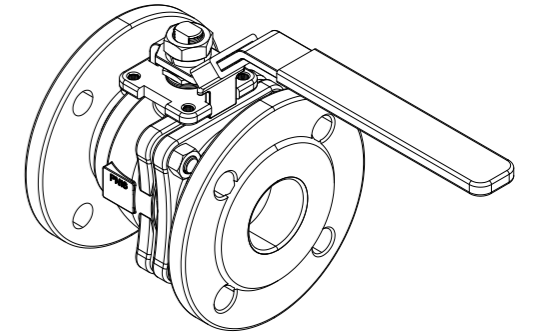

* NOT SHOWN IN DIMENSIONAL VIEW ABOVE,
ONLY APPLICABLE FOR SIZES DN125-DN300



BALL VALVE

2-PC., FULL BORE, FLANGED ENDS

445164
PN40

DESCRIPTION: Two piece, full bore, cast steel body ball valve with AISI 304 ball and PTFE seat ring. Raised face flanged.

APPLICATION: Start/stop flow of: Compressed air, gases and liquids. Typically also used for drain and vent purposes.

STANDARD & DESIGN:

Design Code: ASME B16.34
 Inspection Std.: EN 12266-1
 End Std.: PN40 DIN 2635
 Face to Face Std.: DIN 3202-F4
 Top Flange: ISO 5211(DN15-DN100)
 Flanges Drilled: PN40(DN15-DN100)
 Pressure rating: PN40(DN15-DN100)

VARIATIONS: With Direct Mounting Pad , Fire Safe version.
 Various actuators.
 Other dimensions and materials on request.

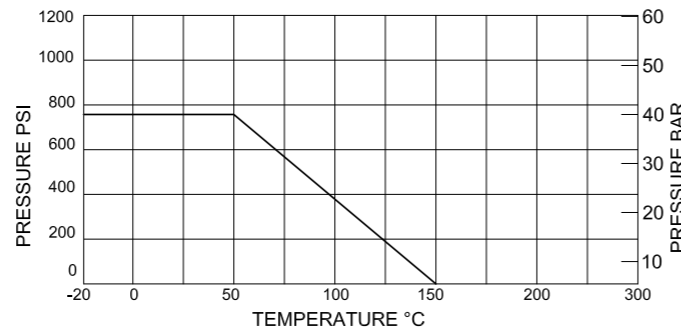
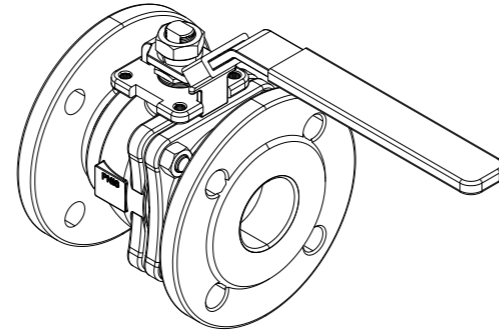

No	Part	Material	Code
1	Body	Cast Steel	1.0619
2	Cap	Cast Steel	1.0619
3	Gland	Stainless Steel	SUS304
4	Ball	Stainless Steel	1.4308
5	Seat	PTFE	-
6	Stem	Stainless Steel	SUS304
7	Bonnet Gasket	PTFE	-
8	Thrust Washer	PTFE	-
9	Packing	PTFE	-
10	Spring Washer	Stainless Steel	SUS304
11	Stem Nut	Stainless Steel	SUS304
12	Locking Device	Stainless Steel	SUS304
13	Bolt	Carbon Steel	-
14	Nut	Carbon Steel	-
15	Handle Cover	Plastic	-
16	Handle	Stainless Steel	SUS304

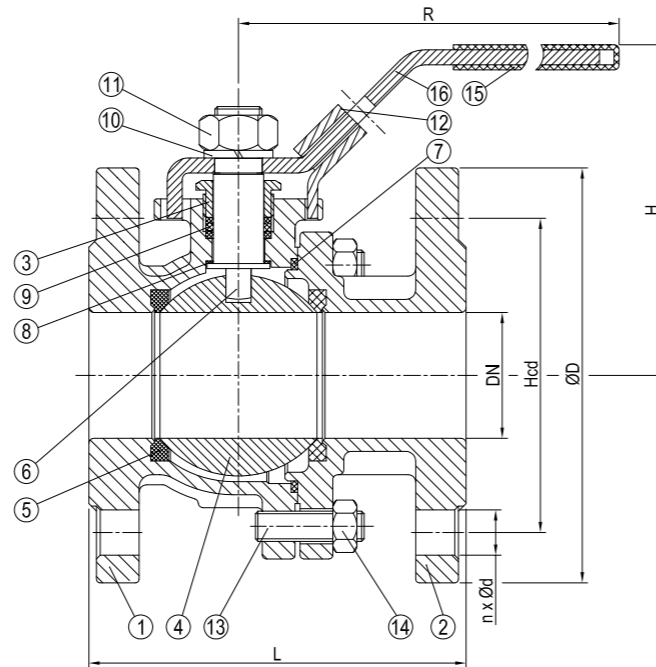

DN	n x ød	Hcd	øD	L	H	R	Kg
15	4x14	65	95	115	76	153	2.5
20	4x14	75	105	120	78	153	3.1
25	4x14	85	115	125	92	188	4.6
32	4x18	100	140	130	95	188	5.6
40	4x18	110	150	140	126	245	7.1
50	4x18	125	165	150	132	245	9.7
65	8x18	145	185	170	166	288	14.8
80	8x18	160	200	180	176	288	19.3
100	8x22	190	235	190	190	388	26.3



BALL VALVE

2-PC., FULL BORE, FLANGED ENDS

445192
PN16

DESCRIPTION: Two piece, full bore, AISI 316 equivalent body ball valve with AISI 316 ball and PTFE seat ring. Raised face flanged.

APPLICATION: Start/stop flow of: Compressed air, gases and acidic media etc. Typically also used for drain and vent purposes.

STANDARD & DESIGN:

Design Code: ASME B16.34
 Inspection Std.: EN 12266-1
 End Std.: PN16 DIN 2633
 Face to Face Std.: DIN 3202-F4 / F5
 Top Flange: ISO 5211(DN15-DN300)
 Flanges Drilled: PN16(DN15-DN300)
 Pressure rating: PN16(DN15-DN300)

VARIATIONS: With Direct Mounting Pad, Fire Safe version.
 Various actuators.
 Other dimensions and materials on request.

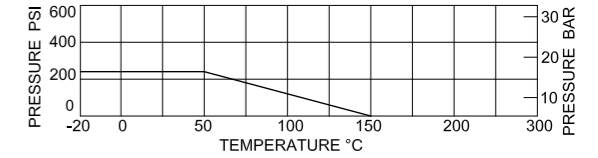
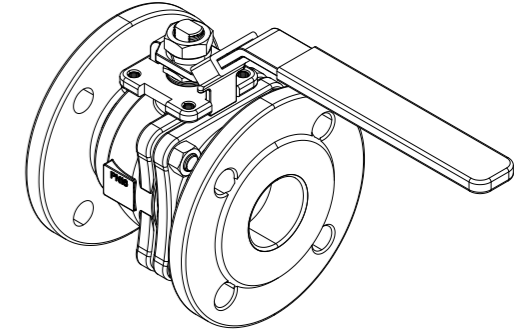

No	Part	Material	Code
1	Body	Stainless Steel	1.4408
2	Cap	Stainless Steel	1.4408
3	Gland	Stainless Steel	SUS304
4	Gland*	Stainless Steel	1.4308
5	Ball	Stainless Steel	1.4308
6	Seat	PTFE	-
7	Stem	Stainless Steel	SUS316
8	Bonnet Gasket	PTFE	-
9	Thrust Washer	PTFE	-
10	Packing	PTFE	-
11	Spring Washer	Stainless Steel	SUS304
12	Stem Nut	Stainless Steel	SUS304
13	Locking Device	Stainless Steel	SUS304
14	Bolt	Stainless Steel	SUS304
15	Nut	Stainless Steel	SUS304
16	Gland Bolt*	Stainless Steel	SUS304
17	Stopper*	Stainless Steel	SUS304
18	Snap Ring*	Stainless Steel	SUS304
19	Handle Cover	Plastic Cover	-
20	Handle	Stainless Steel	SUS304

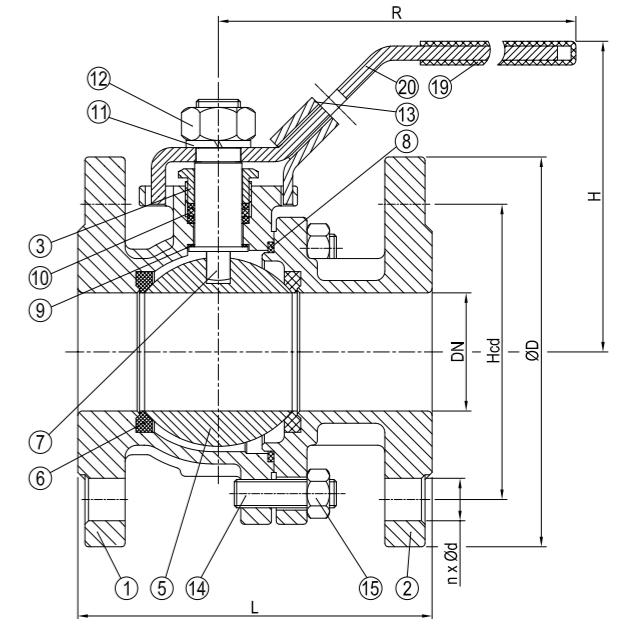

* NOT SHOWN IN DIMENSIONAL VIEW ABOVE,
 ONLY APPLICABLE FOR SIZES DN125-DN300

DN	n x ød	Hcd	øD	L	H	R	Kg
15	4x14	65	95	115	76	153	2.4
20	4x14	75	105	120	78	153	3.2
25	4x14	85	115	125	92	188	3.9
32	4x18	100	140	130	95	188	5.4
40	4x18	110	150	140	126	245	6.7
50	4x18	125	165	150	132	245	9.6
65	8x18	145	185	170	166	288	13.8
80	8x18	160	200	180	176	288	18.3
100	8x18	180	220	190	190	388	23.7
125	8x18	210	250	325	224	750	38.7
150	8x22	240	285	350	247	750	52.9
200	12x22	295	340	400	305	1000	91.1
250	12x26	355	405	450	327	1000	169.2
300	12x26	410	460	500	355	1000	-



BALL VALVE

2-PC., FULL BORE, FLANGED ENDS

445194
PN40

DESCRIPTION: Two piece, full bore, AISI 316 equivalent body ball valve with AISI 316 ball and PTFE seat ring. Raised face flanged.

APPLICATION: Start/stop flow of: Compressed air, gases and acidic media etc. Typically also used for drain and vent purposes.

STANDARD & DESIGN:

Design Code: ASME B16.34
 Inspection Std.: EN 12266-1
 End Std.: PN40 DIN 2635
 Face to Face Std.: DIN 3202-F4
 Top Flange: ISO 5211(DN15-DN100)
 Flanges Drilled: PN40(DN15-DN100)
 Pressure rating: PN40(DN15-DN100)

VARIATIONS: With Direct Mounting Pad, Fire Safe version. Various actuators. Other dimensions and materials on request.

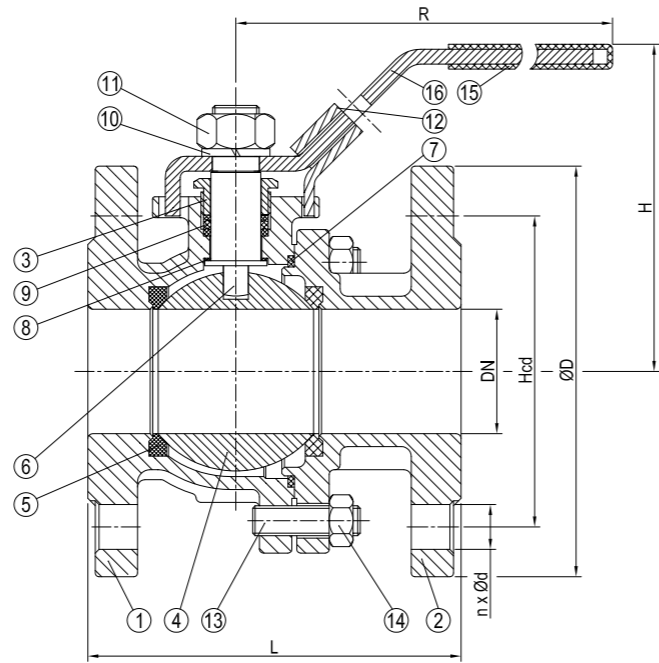
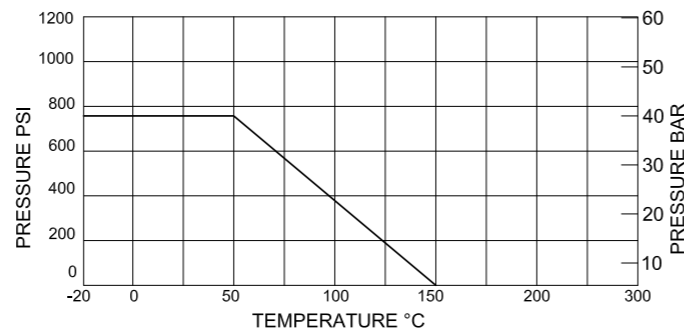
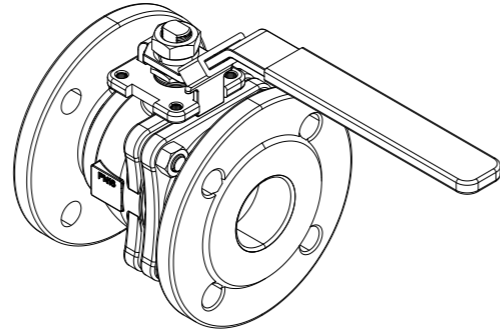

No	Part	Material	Code
1	Body	Stainless Steel	1.4408
2	Cap	Stainless Steel	1.4408
3	Gland	Stainless Steel	SUS304
4	Ball	Stainless Steel	1.4408
5	Seat	PTFE	-
6	Stem	Stainless Steel	SUS316
7	Bonnet Gasket	PTFE	-
8	Thrust Washer	PTFE	-
9	Packing	PTFE	-
10	Spring Washer	Stainless Steel	SUS304
11	Stem Nut	Stainless Steel	SUS304
12	Locking Device	Stainless Steel	SUS304
13	Bolt	Stainless Steel	SUS304
14	Nut	Stainless Steel	SUS304
15	Handle Cover	Plastic	-
16	Handle	Stainless Steel	SUS304

DN	n x ød	Hcd	øD	L	H	R	Kg
15	4x14	65	95	115	76	153	2.5
20	4x14	75	105	120	78	153	3.1
25	4x14	85	115	125	92	188	4.6
32	4x18	100	140	130	95	188	5.6
40	4x18	110	150	140	126	245	7.1
50	4x18	125	165	150	132	245	9.7
65	8x18	145	185	170	166	288	14.8
80	8x18	160	200	180	176	288	19.3
100	8x22	190	235	190	190	388	26.3



BALL VALVE

FULL BORE, FLANGED ENDS, COMPACT TYPE

446152
PN16

DESCRIPTION: Two piece, full bore short length, grey cast iron body ball valve with hard chromed brass ball and PTFE seat ring.

APPLICATION: Water, Conditioning, Heating, Industry, Drinking water, Fire fighting. Start/stop flow of: Compressed air, gases and liquids. Typically also used for drain and vent purposes.

STANDARD & DESIGN:

Design Code: EN 1983, EN13445, ISO 5211
 Inspection Std.: EN 12266 cat. A (ISO 5208 cat. A)
 End Std.: EN 1092
 Flanges drilled: PN16 (DN20-DN100)
 Top Flange: ISO 5211 (DN20-DN100)
 Pressure rating: PN16(DN20-DN100)

VARIATIONS: Available with brass and stainless steel (AISI 304) ball. Available with end std. ANSI B16.5 #150. Other dimensions and materials on request.

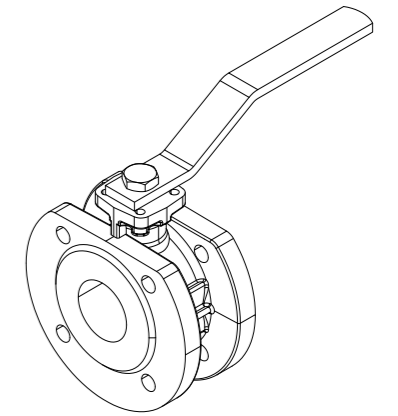

Pressure/temperature chart

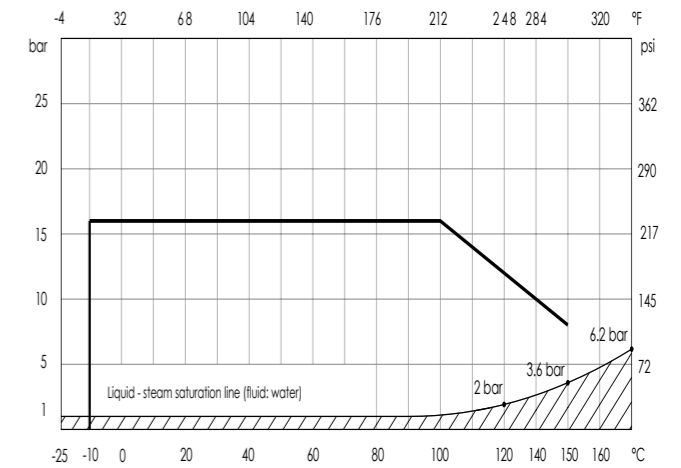

RANGE NOT SUITABLE FOR STEAM. DO NOT use when temperature and pressure are below the liquid-steam saturation line (hatched area)

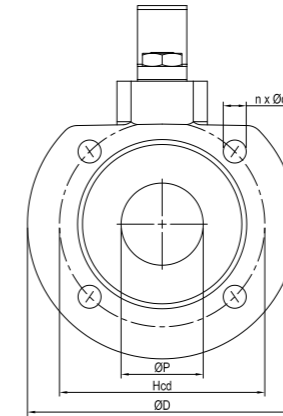

No	Part	Material	Code
1	Body	Cast Iron	EN GJL 250
2	Ball	Brass	CuZn40Pb2
3	Ball Seat	PTFE	-
4	Stem	Brass	CuZn40Pb2
5	Flange	Cast Iron	EN GJL 250
6	Sliding Washer	PTFE	-
7	Ring	Brass	CuZn40Pb2
8	O-ring	NBR	-
9	Lever	Carbon Steel	-
10	Stop Plate	Galvanized Carbon Steel	-
11	Spring Washer	Galvanized Carbon Steel	-
12	Nut	Galvanized Carbon Steel	-

DN	n x ød	Hcd	øD	L	H	H2	R	øP	Kg
20	4 X M12	75	105	40	83	52	160	20	1.9
25	4 X M12	85	115	50	96	59	170	25	2.5
32	4 X M16	100	140	55	101	64	170	32	3.6
40	4 X M16	110	150	65	125	78.5	230	40	5.1
50	4 X M16	125	165	80	133	87	230	50	6.4
65	4 X M16	145	185	100	142	95	230	63	8.8
80	8 X M16	160	200	120	166	118	280	76	11.5
100	8 X M16	180	220	130	181	132.5	360	95	14.8

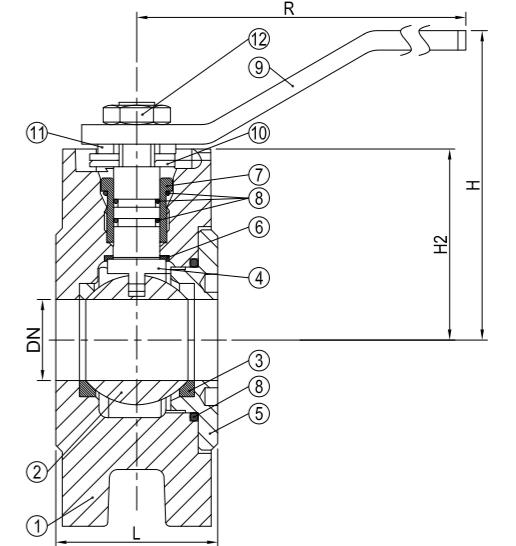



BALL VALVE

FULL BORE, FLANGED ENDS, COMPACT TYPE

446292
PN40/PN16

DESCRIPTION: Two piece, full bore short length, AISI 316 equivalent body ball valve with AISI 316 ball and PTFE seat ring.

APPLICATION: Start/stop flow of: Compressed air, gases and acidic media etc. Typically also used for drain and vent purposes.

VARIATIONS: Other dimensions and materials on request.

STANDARD & DESIGN:

Design Code: ASME B16.34
 Inspection Std.: API 598
 End Std.: DIN 2501-PN16
 Face to Face Std.: -
 Flanges Drilled: PN16-40 (DN15-DN50)
 PN10-16 (DN65-DN100)
 Pressure rating: PN16-40(DN15-DN50)
 PN10-16(DN65-DN100)
 Temperature Range: -20°C to 200°C

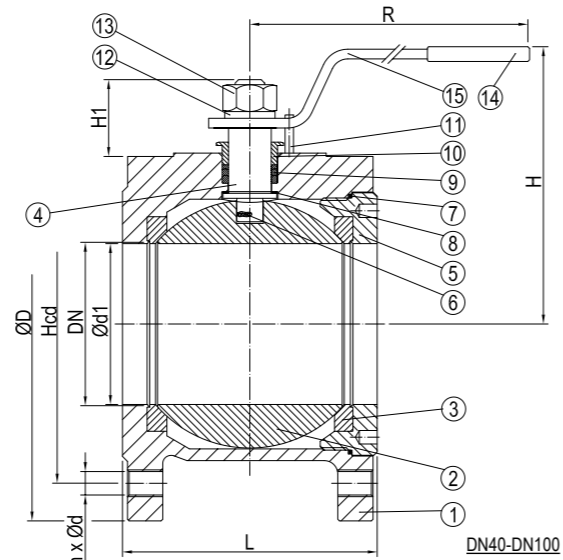
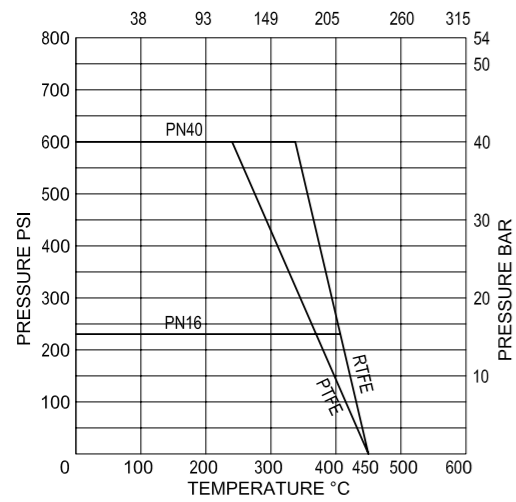
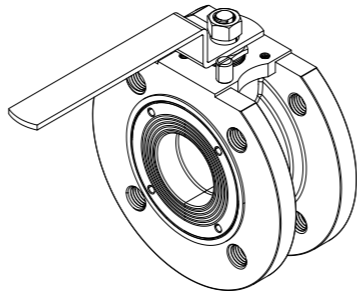

No	Part	Material	Code
1	Body	Stainless Steel	ASTM A351-CF8M
2	Ball	Stainless Steel	ASTM A351-CF8M
3	Ball Seat	RTFE	-
4	Stem	Stainless Steel	ASTM A276-316
5	Retainer	Stainless Steel	ASTM A351-CF8M
6	Anti-Static Device	Stainless Steel	AISI 316
7	Body Seal	PTFE	-
8	Thrust Washer	PTFE	-
9	Packing	PTFE	-
10	Gland Nut	Stainless Steel	AISI 304
11	Stop Pin	Stainless Steel	AISI 304
12	Spring Washer	Stainless Steel	AISI 304
13	Nut	Stainless Steel	AISI 304
14	Handle Cover	PVC	-
15	Handle	Stainless Steel	-

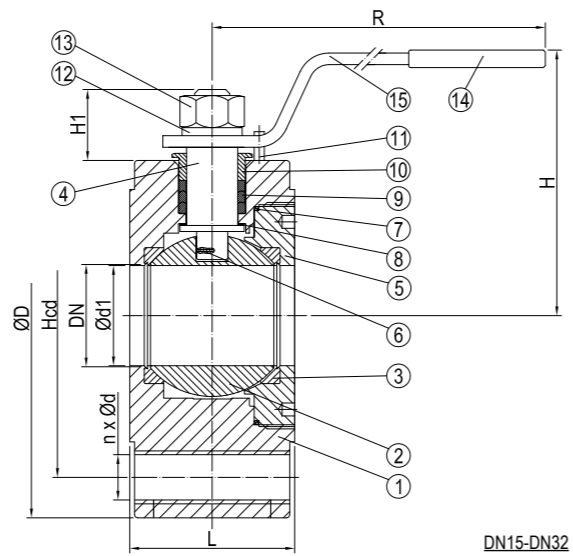

DN	n x ød	Hcd	øD	L	H	H1	ød1	R	Kg
15	4xM12	65	88	36	70	21.7	15	150	1.2
20	4xM12	75	98	38	70	22	20	150	1.4
25	4xM12	85	108	43	80	25	25	150	1.9
32	4xM16	100	128	51	87	28	32	156	2.9
40	4xM16	110	150	63	102	29	38	180	4.4
50	4xM16	125	165	70	108	29	50	180	5.6
65	4xM16	145	186	107	143	41	65	282	9.9
80	8xM16	160	200	120	152	40	76	290	12.6
100	8xM16	180	220	152	168	40	96	325	19.7



BALL VALVE

3-WAY, REDUCED BORE, THREADED ENDS

448095
PN63

DESCRIPTION: 3-way reduced bore AISI 316 equivalent body ball valve with AISI 316 ball and PTFE seat ring. BSPP female thread. With direct mounting pad.

APPLICATION: Stop and distribution valve for: Compressed air, gases and acidic media etc.

STANDARD & DESIGN:

Design Code: ASME B16.34
 Inspection Std.: API-598, EN 12266-1
 End Std.: ISO 228
 Face to Face Std.: -
 Top Flange: ISO 5211(DN8-DN50)
 Pressure rating: PN63(DN8-DN50)

VARIATIONS: Ball design L-port

Ball design T-port

Other dimensions and materials on request.

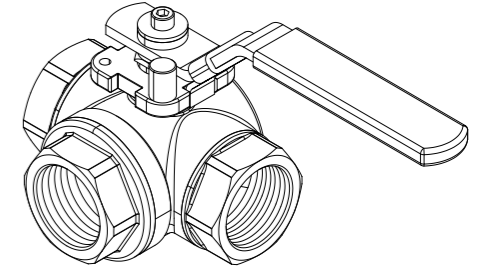
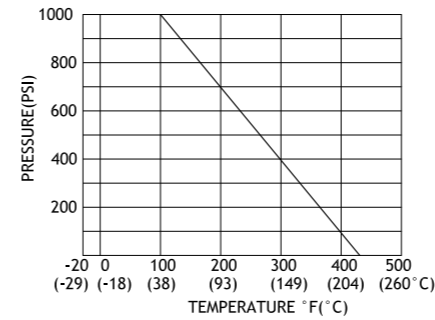

PORT TYPE	0°	90°	180°	270°
L				
T				

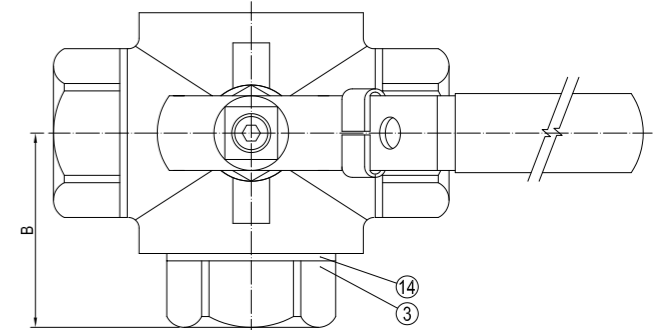

No	Part	Material	Code
1	Body	Stainless Steel	ASTM-A351-CF8M
2	End Cap	Stainless Steel	ASTM-A351-CF8M
3	End Cap	Stainless Steel	ASTM-A351-CF8M
4	Ball	Stainless Steel	ASTM-A351-CF8M
5	Ball Seat	PTFE	-
6	Stem	Stainless Steel	AISI 316
7	End Seals	PTFE	-
8	Thrust Washer	PTFE	-
9	Gland Nut	Stainless Steel	AISI 304
10	Handle Washer	Stainless Steel	AISI 304
11	Washer	Stainless Steel	AISI 304
12	Handle Nut	Stainless Steel	AISI 304
13	Stem Packing	PTFE	-
14	Locking Device	Stainless Steel	AISI 304
15	Handle Cover	PVC	-
16	Handle	Stainless Steel	AISI 304

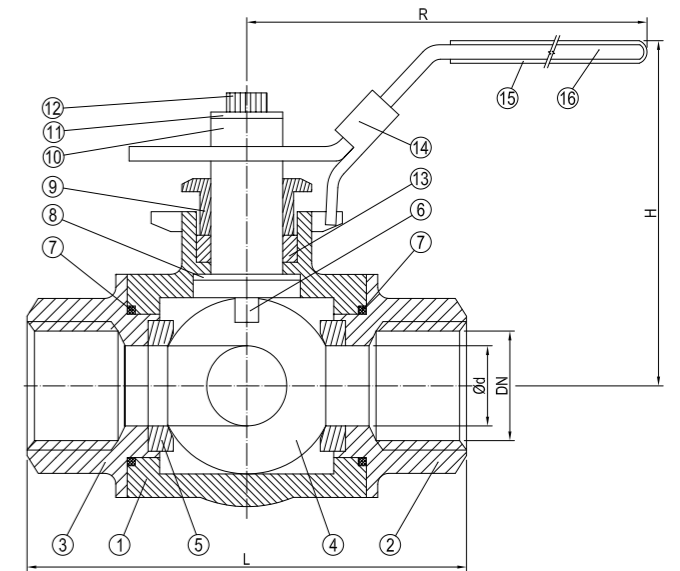

DN	Inch	L	H	ød	B	R	Kg
8	1/4	64	58	11	32	132	0.5
10	3/8	64	58	11	32	132	0.5
15	1/2	75	65	12.7	36	132	0.9
20	3/4	84	82	16	42	180	1.2
25	1	101	90	20	50	180	1.8
32	1 1/4	119	95	25	59	180	2.3
40	1 1/2	130	101	32	62	232	3.7
50	2	148.5	109	38.1	72	232	5.6



BALL VALVE

3-WAY, FULL BORE, FLANGED ENDS

448162
PN16

DESCRIPTION: 3-way full bore cast steel body ball valve with AISI 316 ball and PTFE seat ring. Raised face flanged.

APPLICATION: Stop and distribution valve for: Compressed air, gases and liquids in general etc.

STANDARD & DESIGN:

Design Code: EN 17292
 Inspection Std.: EN 12266-1
 End Std.: EN 1092-1
 Face to Face Std.: -
 Flanges drilled: PN16(DN15-DN100)
 Pressure rating: PN16(DN15-DN100)

VARIATIONS:

Ball design L-port
 Ball design T-port

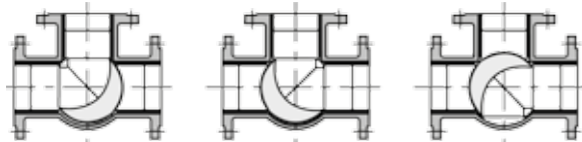
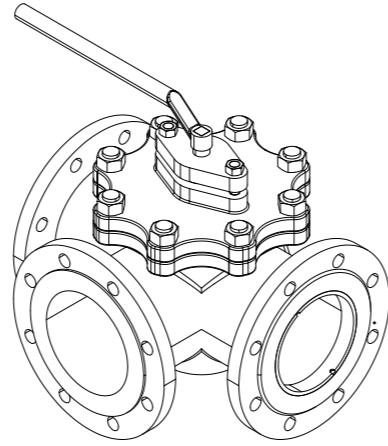

L-PORT

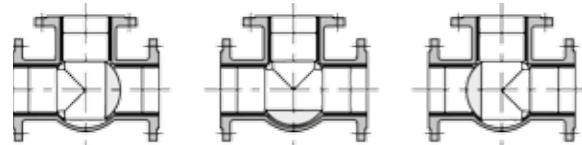

T-PORT

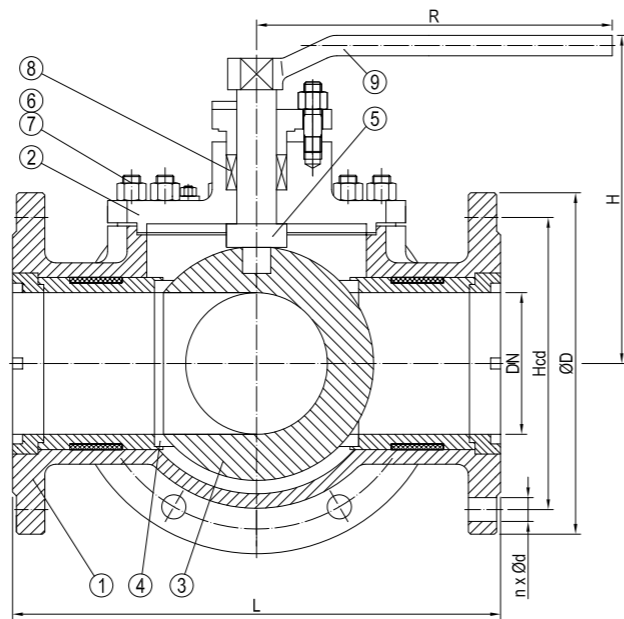

No	Part	Material	Code
1	Body	Cast Steel	ASTM A216-WCB
2	Bonnet	Cast Steel	ASTM A216-WCB
3	Ball	Stainless Steel	ASTM A182-F316
4	Seat	RPTFE	-
5	Stem	Stainless Steel	ASTM A276-420
6	Stud Bolt	Steel	ASTM A193 Gr.B7
7	Nut	Steel	ASTM A194 Gr.2H
8	Packing	PTFE	-
9	Handle	Steel	-

DN	n x ød	Hcd	øD	L	H	R	Kg
15	4x14	65	95	140	95	140	4
20	4x14	75	105	160	105	160	5
25	4x14	85	115	180	113	180	7
32	4x18	100	140	200	135	250	12
40	4x18	110	150	220	142	300	15
50	4x18	125	165	240	154	350	20
65	4x18	145	185	260	175	350	25
80	8x18	160	200	280	190	400	36
100	8x18	180	220	320	225	500	51



BALL VALVE

3-WAY, FULL BORE, FLANGED ENDS

448162 WITH GEAR
PN16

DESCRIPTION: 3-way full bore cast steel body ball valve with AISI 316 ball and PTFE seat ring. Raised face flanged. With hand wheel gear.

APPLICATION: Stop and distribution valve for: Compressed air, gases and liquids in general etc.

STANDARD & DESIGN:

Design Code: EN 17292
 Inspection Std.: EN 12266-1
 End Std.: EN 1092-1
 Face to Face Std.: -
 Flanges drilled: PN16(DN125-DN200)
 Pressure rating: PN16(DN125-DN200)

VARIATIONS:

Ball design L-port
 Ball design T-port

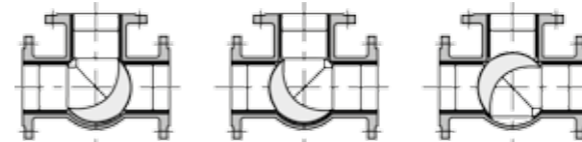
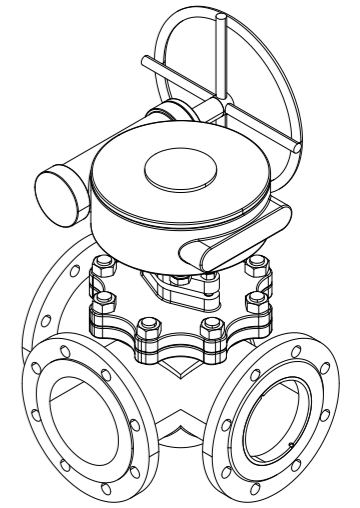

L-PORT

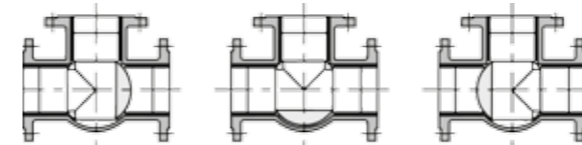

T-PORT

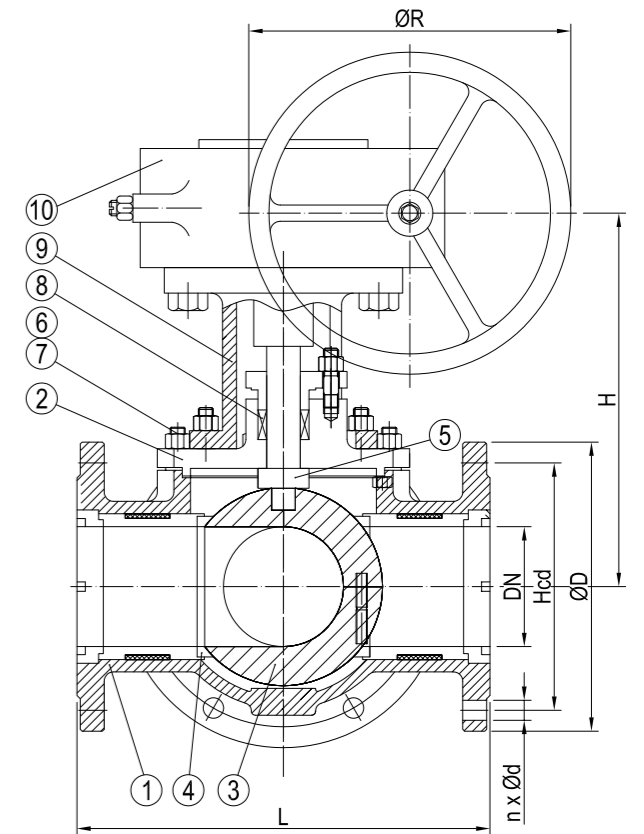

No	Part	Material	Code
1	Body	Cast Steel	ASTM A216-WCB
2	Bonnet	Cast Steel	ASTM A216-WCB
3	Ball	Stainless Steel	ASTM A182-F316
4	Seat	RPTFE	-
5	Stem	Stainless Steel	ASTM A276-420
6	Stud Bolt	Steel	ASTM A193 Gr.B7
7	Nut	Steel	ASTM A194 Gr.2H
8	Packing	PTFE	-
9	Yoke	Steel	-
10	Gear Actuator	-	-

DN	n x ød	Hcd	øD	L	H	øR	Kg
125	8x18	210	250	380	245	600	77
150	8x22	240	285	440	265	800	108
200	12x22	295	340	550	305	800	126



BALL VALVE

3-WAY, FULL BORE, FLANGED ENDS

448192
PN16

DESCRIPTION: 3-way full bore AISI equivalent body ball valve with AISI 316 ball and PTFE seat ring. Raised face flanged. With direct mounting pad.

APPLICATION: Stop and distribution valve for: Compressed air, gases and acidic media etc.

STANDARD & DESIGN:

Design Code: ASME B16.34
 Inspection Std.: API 598
 End Std.: DIN 2633 PN16
 Top Flange: ISO 5211(DN15-DN100)
 Face to Face Std.: -
 Flanges Drilled: PN16(DN15-DN100)
 Pressure rating: PN16(DN15-DN100)
 Temperature Range: -20°F to 450°F

VARIATIONS: Various actuators, Ball design L-port, Ball design T-port, Other dimensions and materials on request.

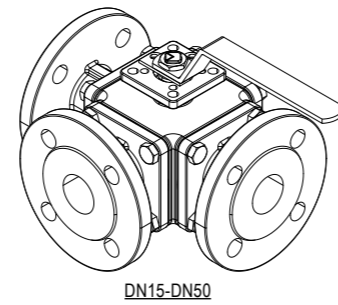
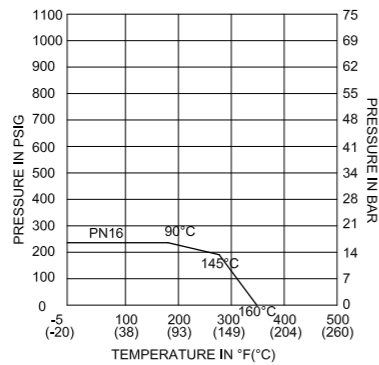

No	Part	Material	Code
1	Body	Stainless Steel	A351 Gr. CF8M
2	Bonnet	Stainless Steel	A351 Gr. CF8M
3	Gland	Stainless Steel	SS 304
4	Ball	Stainless Steel	SS 316
5	Ball & Stem	Stainless Steel	SS 316
6	Seats	PTFE/RPTFE	-
7	Stem	Stainless Steel	SS 316
8	Flange End	Stainless Steel	ASTM Gr. CF8M
9	Gasket	PTFE	-
10	Bonnet Gasket	PTFE	-
11	Stem Seal	RPTFE	-
12	O-Ring	Viton	-
13	Stem Packing	Graphite	-
14	Belleville Washer	Stainless Steel	SS 301
15	Stem Nut	Stainless Steel	SS 304
16	Nut Stop	Stainless Steel	SS 304
17	Space Washer	Stainless Steel	SS 304
18	Nameplate	Stainless Steel	SS 304
19	Handle Nut	Stainless Steel	SS 304
20	Stop Pin	Stainless Steel	SS 304
21	Insert Pin	Stainless Steel	SS 316
22	Blank End	Stainless Steel	A351 Gr. CF8M
23	Bolt	Stainless Steel	SS 304
24	Pin Nut	Stainless Steel	SS 304
25	Anti-Static Device	Stainless Steel	SS 316
26	Housing	RPTFE+Stainless Steel	-
27	Gland Washer	Stainless Steel	SS 304
28	Disc Washer	Stainless Steel	SS 301
29	Handle Head	Stainless Steel	ASTM Gr.CF8
30	Connection Bolts	Steel	B8
31	Bolt Nuts	Stainless Steel	SS 304
32	Stop Pin Nut	Stainless Steel	SS 304
33	Handle Cover	Vinyl	-
34	Handle	Stainless Steel	SS 304
35	Lever	Carbon Steel	-

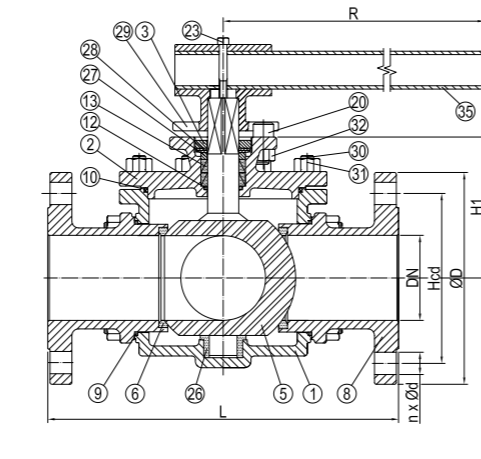
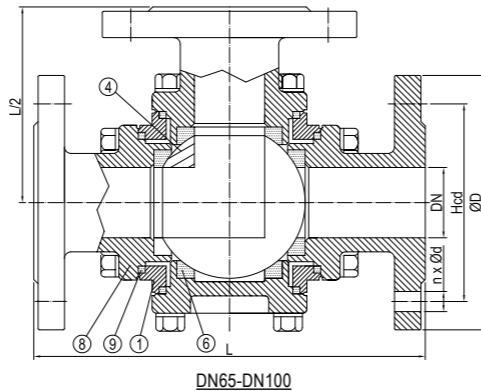
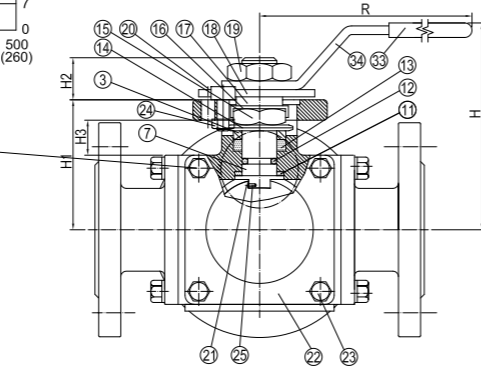
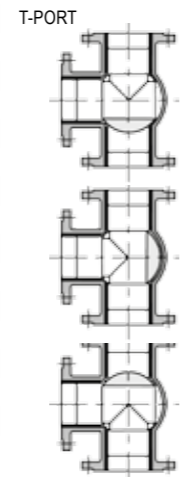
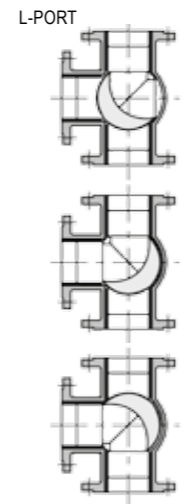
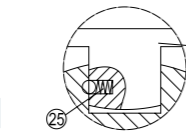

DN	n x ød	Hcd	øD	L	H	H1	H2	H3	R	Kg
15	4x14	65	95	160	62	41	11	10	130	4.4
20	4x14	75	105	177	82	49	14	13	165	5.6
25	4x14	85	115	190	89	55	14	15.5	165	7.2
32	4x18	100	140	208	98	63	18	16.7	205	10.5
40	4x18	110	150	234	108	74	18	17.5	205	14.5
50	4x18	125	165	273	140	93	23	26	325	23.5
65	4x18	145	185	300	-	118.5	-	-	400	-
80	8x18	160	200	305	-	136.5	-	-	500	-
100	8x18	180	220	368.5	-	156.5	-	-	650	-



BALL VALVE

3-WAY, FULL BORE, FLANGED ENDS

448395
1000WOG/
800WOG

DESCRIPTION: 3-way full bore AISI equivalent body ball valve with AISI 316 ball and reinforced PTFE seat ring. Female BSPP threaded ends. With direct mounting pad.

APPLICATION: Stop and distribution valve for: Compressed air, gases and acidic media etc.

STANDARD & DESIGN:

Design Code: ASME B16.34
 Inspection Std.: API-598
 End Std.: ISO 228
 Face to Face Std.: -
 Top Flange: ISO 5211(DN8-DN50)
 Pressure rating: 1000WOG(DN8-DN25)
 800WOG(DN32-DN50)
 Temperature Range: -20°F to 450°F

VARIATIONS: Available in ball T-port and ball L-port. Other dimensions and materials on request.

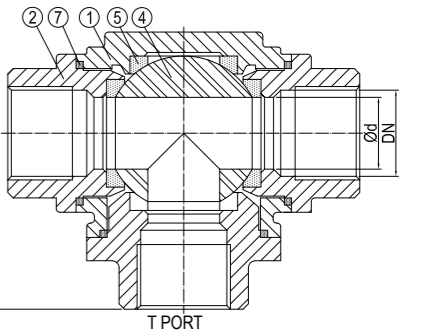
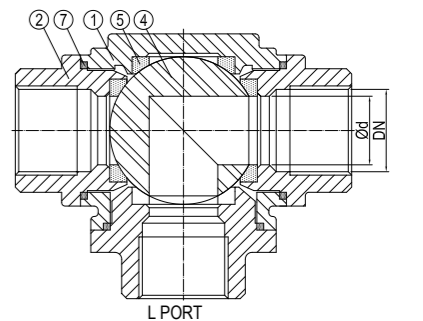
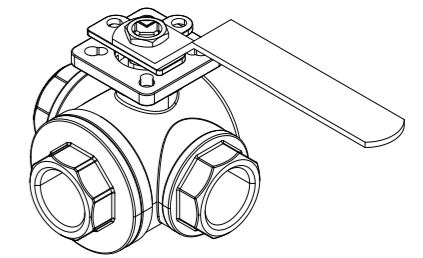
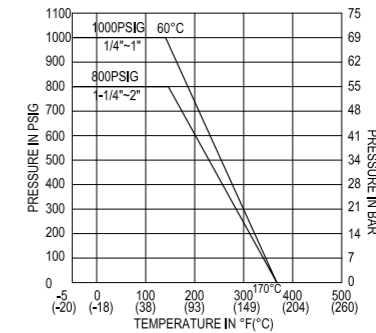

No	Part	Material	Code
1	Body	Stainless Steel	A351 Gr. CF8M
2	End Cap	Stainless Steel	A351 Gr. CF8M
3	Gland	Stainless Steel	SS 304
4	Ball	Stainless Steel	SS 316
5	Seats	PTFE/RPTFE	-
6	Stem	Stainless Steel	SS 316
7	Bonnet Gasket	PTFE	-
8	Stem Seal	RPTFE	-
9	O-Ring	VITON	-
10	Stem Packing	Graphite	-
11	Belleville Washer	Stainless Steel	SS 301
12	Stem Nut	Stainless Steel	SS 304
13	Nut Stop	Stainless Steel	SS 304
14	Space Washer	Stainless Steel	SS 304
15	Plate Stop	Stainless Steel	SS 304
16	Handle Nut	Stainless Steel	SS 304
17	Stopper	Stainless Steel	SS 304
18	Insert Pin	Stainless Steel	SS 316
19	Pin Nut	Stainless Steel	SS 304
20	Antistatic Device	Stainless Steel	SS 316
21	Handle Cover	Vinyl	-
22	Handle	Stainless Steel	SS 304

DN	Inch	L	L1	H	H1	H2	H3	H4	ød	R	Kg
8	1/4	72	36	62	38.5	11	11.8	20	11	130	0.5
10	3/8	72	36	62	38.5	11	11.8	20	12	130	0.5
15	1/2	83	41.5	64	41	11	13.4	23.2	15	130	0.9
20	3/4	99	49.5	82	49	14	14.8	28	20	165	1.5
25	1	112	56	89	55	14	15	34	25	165	2.2
32	1 1/4	125	62.5	98	63	18	16.2	39	32	205	3.2
40	1 1/2	149	74.5	108	74	18	16.5	48	38	205	5.4
50	2	174	87	140	93	22	24.2	60	50	325	9.7

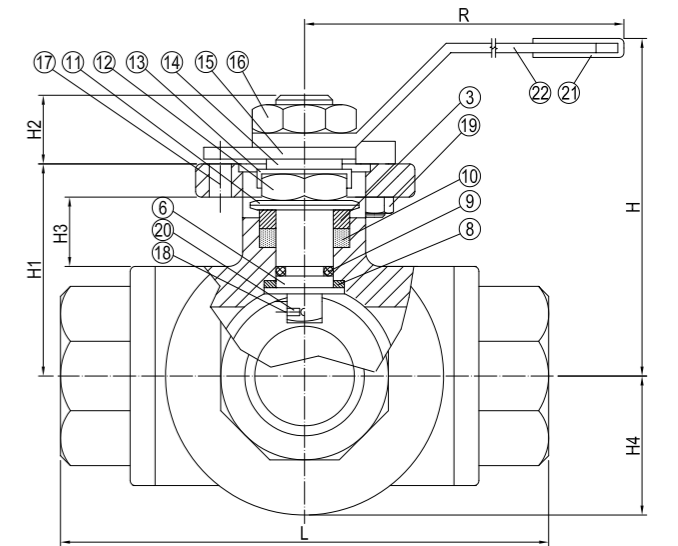



SAFETY VALVES & CONTROL VALVES

Safety valves and pressure reducing available in straight and angle patterns.
Safety valves as proportional or full lift type.
Available with flanged or threaded end connections.



AIR INLET VALVE

VACUUM PREVENTING, SPING LOADED,
THREADED END

414212

DESCRIPTION: Spring loaded brass body vacuum preventing valve with metallic seal. Male BSPP thread.

APPLICATION: Prevention of vacuum in piping systems due to e.g. heating and cooling of non aggressive liquids.

STANDARD & DESIGN:

Design Code: -
 Inspection Std.: -
 End Std.: DIN EN ISO 228
 Face to Face Std.: -
 Pressure rating: -
 Temperature Range: -10°C to 225°C

VARIATIONS: Other dimensions and materials on request.

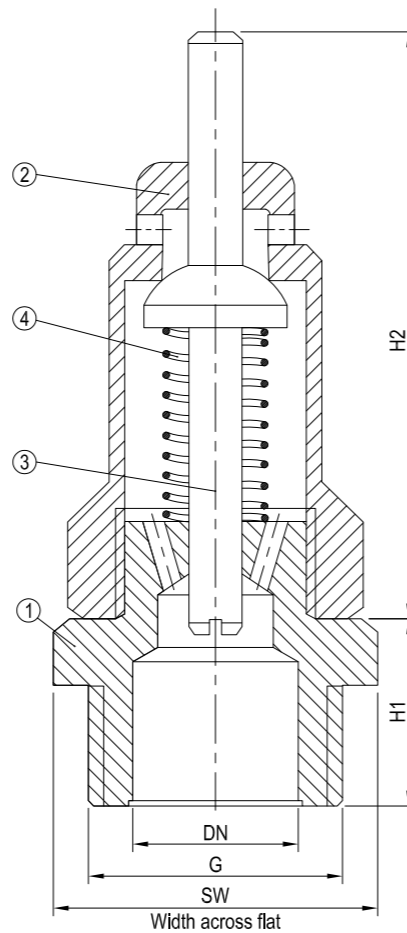
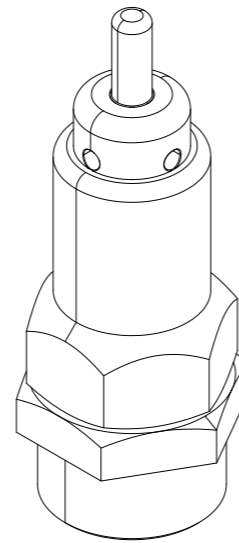

No	Part	Material	Code
1	Body	Brass	CuZn39Pb3
2	Cap (with vent holes)	Brass	CuZn39Pb3
3	Stem	Brass	CuZn39Pb3
4	Spring	Spring Steel	1.1200

DN	G(inch)	H1	H2	SW	Kg
10	3/8	10	55	22	0.1
15	1/2	11	55	22	0.1
20	3/4	12	66	29	0.2



PRESSURE REDUCING VALVE

THREADED ENDS

470923

DESCRIPTION: Straight Rg5 body adjustable pressure reducing valve with NBR seal. Outlet pressure range 1,5-10 bar. Single manometer fitting. Female BSPP thread.

APPLICATION: Commercial and industrial plants, compressed air supply plants, pneumatic control units, pressure booster plants air-side, shipbuilding industry and offshore plants. Avoiding distributing line over pressure or pressure peaks due to variations in supply line pressure in neutral non viscous liquids, air, gases and vapours. Not for steam.

STANDARD & DESIGN:

Design Code: -
 Inspection Std.: -
 End Std.: DIN EN ISO 228-1 (Inlet & Outlet)
 Face to Face Std.: -
 Inlet Pressure: Max. 50 bar(DN10-DN25)
 Max. 30 bar(DN32)
 Outlet Pressure: 1.5 - 10 bar
 Largest reduction ratio: 10:1
 Temperature Range: -10°C to 95°C

VARIATIONS: Other dimensions and materials on request.

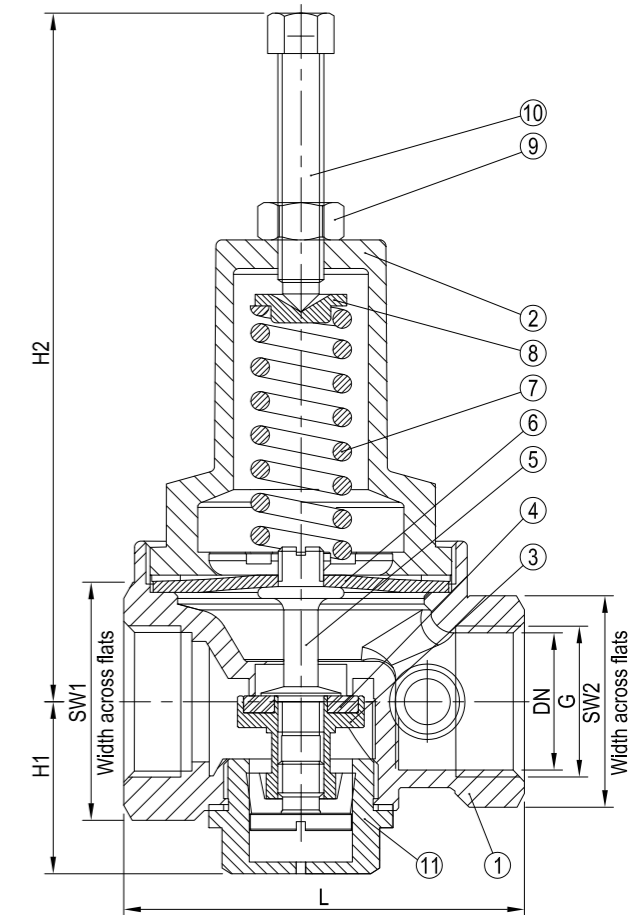
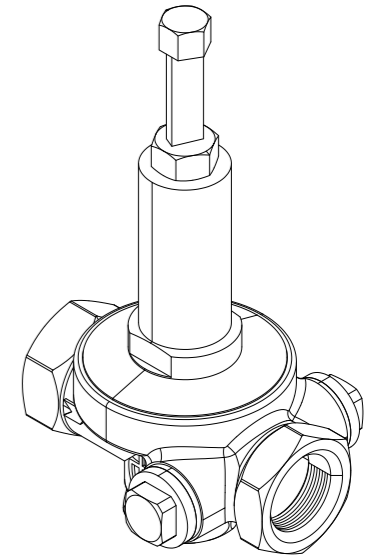

No	Part	Material	Code
1	Body	Bronze	CC499K
2	Bonnet	Bronze	CC499K
3	Disc	Brass	CW614N
4	Seal	NBR	-
5	Stem	Brass	CW614N
6	Diaphragm	NBR	-
7	Spring	Spring Steel	1.1200
8	Spring Retainer	Brass	CW614N
9	Locknut	Brass	CW614N
10	Pressure Adjusting Screw	Brass	CW614N
11	Plug	Brass	CW614N

DN	G(inch)	L	H1	H2	SW1	SW2	Kg
10	3/8	73	22	100	27	27	0.5
15	1/2	73	22	100	27	27	0.5
20	3/4	70	30	120	36	32	0.8
25	1	87	35	165	44	40	1.4
32	1 1/4	100	43	175	54	49	2.0



PRESSURE REDUCING VALVE

THREADED ENDS

471023
PN40

DESCRIPTION: Straight Rg5 body adjustable pressure reducing valve with NBR seal. Outlet pressure range 1,5-20 bar. Single manometer fitting. Female BSPP thread.

APPLICATION: Avoiding distributing line overpressure or pressure peaks due to variations in supply line pressure in neutral non viscous liquids, air, gases and vapours. Not for steam.

STANDARD & DESIGN:

Design Code:	-
Inspection Std.:	-
End Std.:	ISO 228
Face to Face Std.:	-
Pressure rating:	PN40(DN8-DN50)
Working(inlet) pressure:	Max. 40 bars
Outlet pressure range:	1.5 to 20 bars
Highest reduction ratio:	6:1
Maximum temperature:	75°C

VARIATIONS: Available with double manometer fitting. Other dimensions and materials on request.

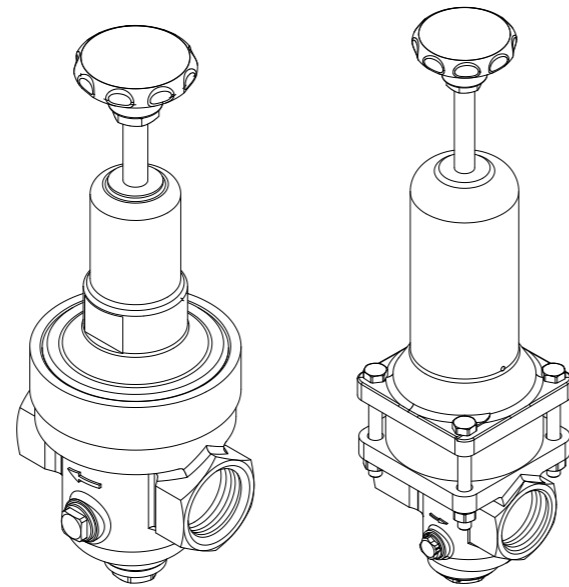

DN8-DN25

DN32-DN50

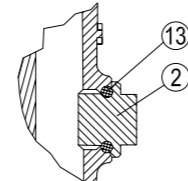

DETAIL AT CLOSING PLUG

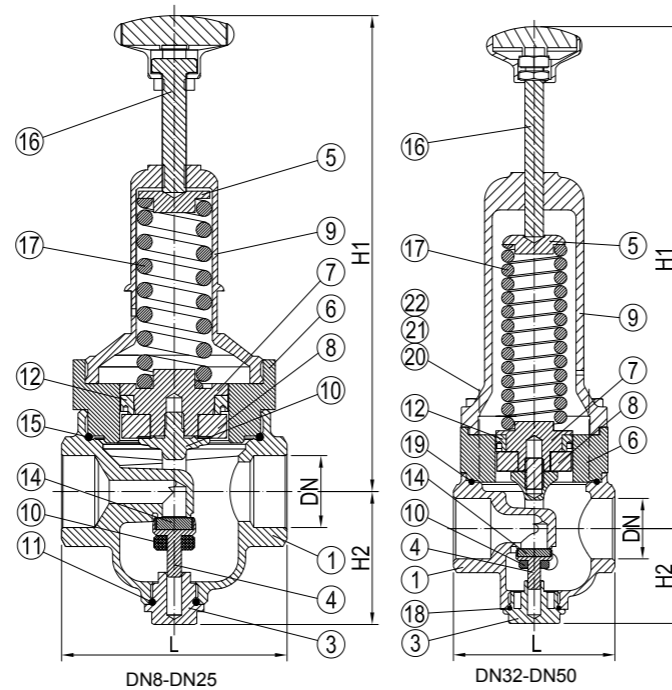

DN8-DN25

DN32-DN50

No	Part	Material	Code
1	Body	Bronze	CuSn5Zn5Pb5-C-GS
2	Closing Plug	Brass	CuZn39Pb3
3	Closing Plug	Brass	CuZn39Pb3
4	Main Seal Holder	Brass	CuZn39Pb3
5	Spring Cap	Brass	CuZn39Pb3
6	Piston Guide	Brass	CuZn39Pb3
7	Piston	Brass	CuZn39Pb3
8	Space Sleeve	Brass	CuZn39Pb3
9	Hood DN8-DN25 DN32-DN50	Brass Cast Iron	CuZn39Pb3 -
10	Swing	Brass	CuZn39Pb3
11	O-Ring (16x2.5mm)	NBR	-
12	Ring	NBR	-
13	O-Ring (10x2mm)	NBR	-
14	Main Seal	NBR	-
15	O-Ring (69x3mm)	NBR	-
16	Complete Handwheel	-	-
17	Spring	Spring Steel	-
18	O-Ring (30x3mm)	NBR	-
19	O-Ring (78x2.5mm)	NBR	-
20	Bolt	Stainless Steel	V2A
21	Nut	Stainless Steel	V2A
22	Spring Lock Washer	Stainless Steel	V2A

DN	Inch	L	H1	H2	Kg
8	1/4	70	141	47	1.2
10	3/8	70	141	47	1.2
15	1/2	85	182	47	1.8
20	3/4	85	182	47	1.8
25	1	95	201	55	2.7
32	1 1/4	104	324	61	6.3
40	1 1/2	108	331	61	6.4
50	2	147	349	72	10.1



PRESSURE REDUCING VALVE

FLANGED ENDS

471223
PN40

DESCRIPTION: Straight Rg5 body adjustable pressure reducing valve with NBR seal. Outlet pressure range 1,5-20 bar. Single manometer fitting. Raised face flanged.

APPLICATION: Avoiding distributing line overpressure or pressure peaks due to variations in supply line pressure in neutral non viscous liquids, air, gases and vapours. Not for steam.

STANDARD & DESIGN:

Design Code:	-
Inspection Std.:	-
End Std.:	DIN 2501 PN 40 Type C
Face to Face Std.:	-
Flanges Drilled:	PN40(DN8-DN50)
Pressure rating:	PN40(DN8-DN50)
Working(inlet) pressure:	Max. 40 bars
Outlet pressure range:	1.5 to 20 bars
Highest reduction ratio:	6:1
Maximum temperature:	75°C

VARIATIONS: Available with double manometer fitting. Other dimensions and materials on request.

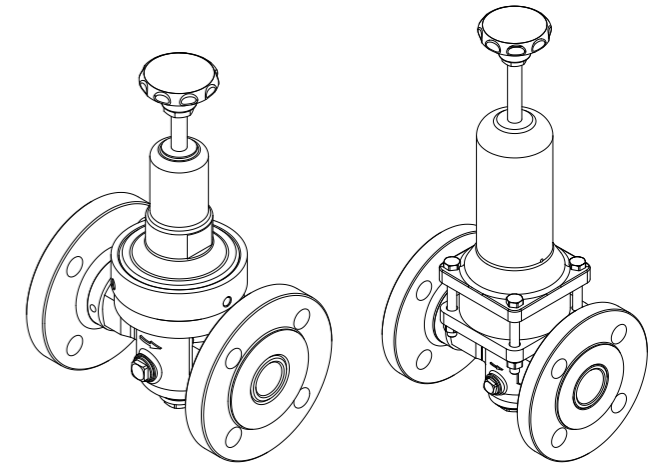

DN8-DN25

DN32-DN50

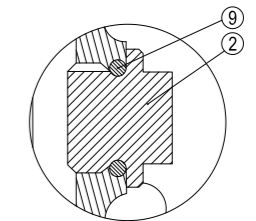

DETAIL AT CLOSING PLUG

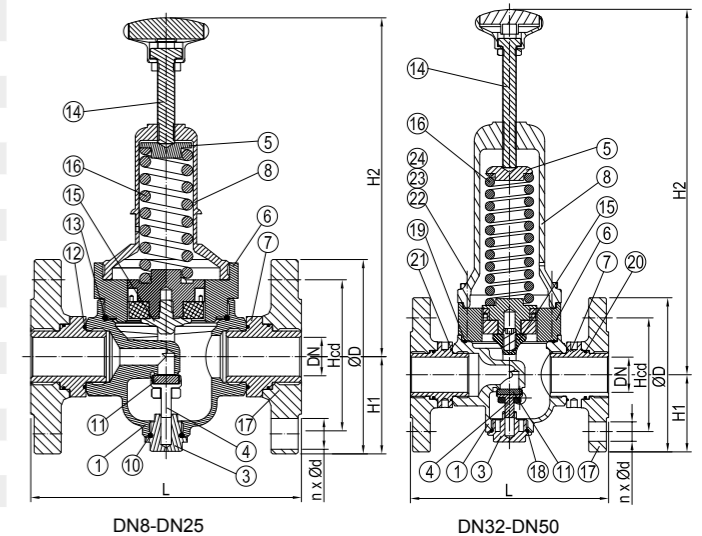

DN8-DN25

DN32-DN50

No	Part	Material	Code
1	Body	Bronze	CuSn5Zn5Pb5-C-GS
2	Closing Plug	Brass	CuZn39Pb3
3	Closing Plug	Brass	CuZn39Pb3
4	Main Seal Holder	Brass	CuZn39Pb3
5	Spring Cap	Brass	CuZn39Pb3
6	Piston Guide	Brass	CuZn39Pb3
7	Connector	Brass	CuZn39Pb3
8	Hood DN8-DN25 DN32-DN50	Brass Cast Iron	CuZn39Pb3 EN-GJL-250
9	O-Ring (10x2mm)	NBR-70° Shore	-
10	O-Ring(16x2.5mm)	NBR-70° Shore	-
11	Main Seal	NBR-80° Shore	-
12	O-Ring(35x1.5mm)	NBR-70° Shore	-
13	O-Ring(69x3mm)	NBR-75° Shore	-
14	Complete Handwheel	-	-
15	Swing	-	-
16	Spring	Spring steel	-
17	Flange	Bronze	RG5
18	O-Ring (30x3mm)	NBR-70° Shore	-
19	O-Ring (78x2.5mm)	NBR-70° Shore	-
20	O-Ring (39x2.5mm)	NBR-70° Shore	-
21	O-Ring (45x1mm)	NBR-70° Shore	-
22	Bolt	Stainless Steel	V2A
23	Nut	Stainless Steel	V2A
24	Spring Lock Washer	Stainless Steel	V2A

DN	n x ød	Hcd	øD	L	H1	H2	Kg
8	-	-	-	130	48	130	1.2
10	4x14	60	90	130	48	130	1.2
15	4x14	65	95	130	48	140	3.4
20	4x14	75	105	150	52.5	140	4.3
25	4x14	85	115	160	57.5	205	5.8
32	4x18	100	140	180	70	230	10.7
40	4x18	110	150	200	75	230	11.7
50	4x18	125	165	230	82.5	295	17.3



PRESSURE CONTROL VALVE

THREADED ENDS

474322

DESCRIPTION: Angled Rg5 body overflow/pressure control valve with PTFE seal. Pressure preset and sealed. Female BSPP thread.

APPLICATION: For the protection of pumps against overloading in closed circuits for neutral/non-neutral, non-sticking liquids.

For the control of systems under pressure for neutral/non-neutral gases and vapours and depending on the sealing material-also for steam. Pump protection, test rig construction, process equipment construction, shipbuilding industry and marine equipment, de-icing technology, mechanical engineering, industrial applications.

STANDARD & DESIGN:

Design Code: -
 Inspection Std.: -
 End Std.: DIN EN ISO 228-1 (Inlet & Outlet)
 Face to Face Std.: -
 Pressure range: 0.2-0.8 bar(DN10-DN50)
 0.5-2.5 bar(DN10-DN50)
 2-12 bar(DN10-DN50)
 12-20 bar(DN10-DN50)
 Temperature Range: -60°C to 225°C

VARIATIONS: Other dimensions and materials on request.

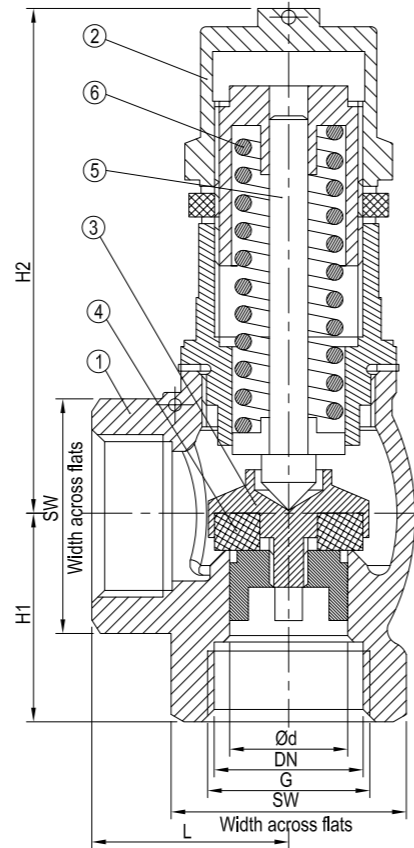
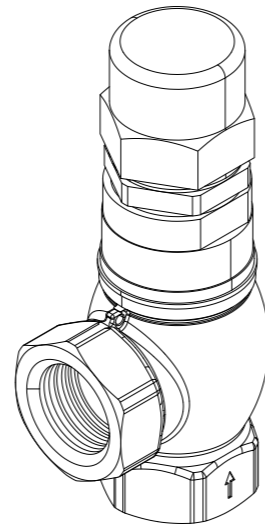

No	Part	Material	Code
1	Body	Bronze	CC499K
2	Bonnet	Brass	CW614N
3	Disc	Brass	CW614N
4	Seal	PTFE	-
5	Stem	Brass	CW614N
6	Spring	Stainless Steel	1.4310

DN	G(inch)	L	H1	H2	ød	SW	Kg
10	3/8	27	26	66	10	24	0.3
15	1/2	29	30	74	13	28	0.4
20	3/4	34	35	83	19	34	0.7
25	1	42	43	100	25	41	1.2
32	1 1/4	46	46	117	30	52	1.9
40	1 1/2	51	52	136	38	58	2.5
50	2	60	61	146	50	70	3.8



SAFETY VALVE

FLANGED ENDS

475102
PN16

DESCRIPTION: Angled body metal seated safety relief valve. Pressure preset and sealed, fitted with manual relief handle. Raised face flanged.

APPLICATION: Prevention of over pressure in steam, gases and liquids. Typically fitted on e.g. steam boilers.

VARIATIONS: Flanges drilled PN25-PN63 alt. Class 150-Class 600(Inlet), PN25-PN40 alt. Class 150-Class 300(Outlet). Other dimensions, executions and materials on request.

STANDARD & DESIGN:

Design Code: -
 Inspection Std.: -
 End Std.: DIN EN / ASME B16.5
 Face to Face Std.: -
 Flanges Drilled: PN16(DN15-DN100)
 Max. set outlet pressure: 40bar(DN15-DN50),
 36bar(DN65), 25bar(DN80),
 18bar(DN100)
 Temperature Range: -10°C to 280°C(DN15-DN25);
 -10°C to 350°C(DN32-DN100)

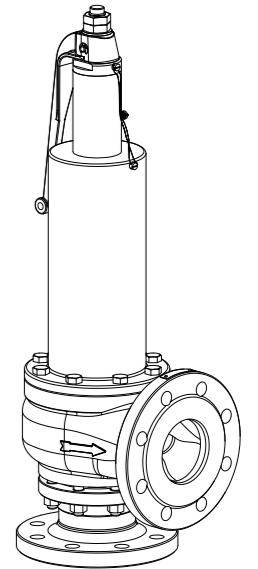

No	Part	Material	Code	
1	Body	DN15-DN25	Steel	1.0460
		DN32-DN40	Cast Steel	1.0619
		DN50-DN65	Cast Steel	1.0619
		DN80-DN100	Cast Steel	1.0619
2	Spring Bonnet	DN15-DN25	Nodular Cast Iron	0.7043
		DN32-DN40	Cast Steel	1.0619
		DN50-DN65	Cast Steel	1.0619
		DN80-DN100	Steel	1.0254
3	Disc	DN15-DN25	Stainless Steel	1.4571
		DN32-DN40	Stainless Steel	1.4571
		DN50-DN65	Stainless Steel	1.4571
		DN80-DN100	Stainless Steel	1.4571
4	Seat	DN15-DN25	Stainless Steel	1.4104
		DN32-DN40	Stainless Steel	1.4571
		DN50-DN65	Stainless Steel	1.4571
		DN80-DN100	Stainless Steel	1.4571
5	Stem	DN15-DN25	Stainless Steel	1.4104
		DN32-DN40	Stainless Steel	1.4104
		DN50-DN65	Stainless Steel	1.4104
		DN80-DN100	Stainless Steel	1.4104
6	Packing Ring	DN15-DN25	TESNIT	-
		DN32-DN40	TESNIT	-
		DN50-DN65	TESNIT	-
		DN80-DN100	PTFE	-
7	Disc Ring	DN15-DN25	-	-
		DN32-DN40	Stainless Steel	1.4301
		DN50-DN65	Stainless Steel	1.4301
		DN80-DN100	Stainless Steel	1.4571
8	Spring	DN15-DN25	Stainless Steel	1.4310
		DN32-DN40	Stainless Steel	1.4310
		DN50-DN65	Stainless Steel	1.4310
		DN80-DN100	Stainless Steel	1.4310
9	Lifting Lever	DN15-DN25	Aluminium	3.2581
		DN32-DN40	Aluminium	3.2581
		DN50-DN65	Aluminium	3.2581
		DN80-DN100	Aluminium	3.2581

DN	n x ød	Hcd	øD	L	H	Kg
15	4x14	65	95	90	282	4.3
20	4x14	75	105	95	287	4.5
25	4x14	85	115	100	292	5.2
32	4x18	100	140	105	395	10.2
40	4x18	110	150	115	405	10.7
50	4x18	125	165	125	450	17.0
65	4x18	145	185	145	470	20.3
80	8x18	160	200	155	700	38.2
100	8x18	180	220	175	730	40.5

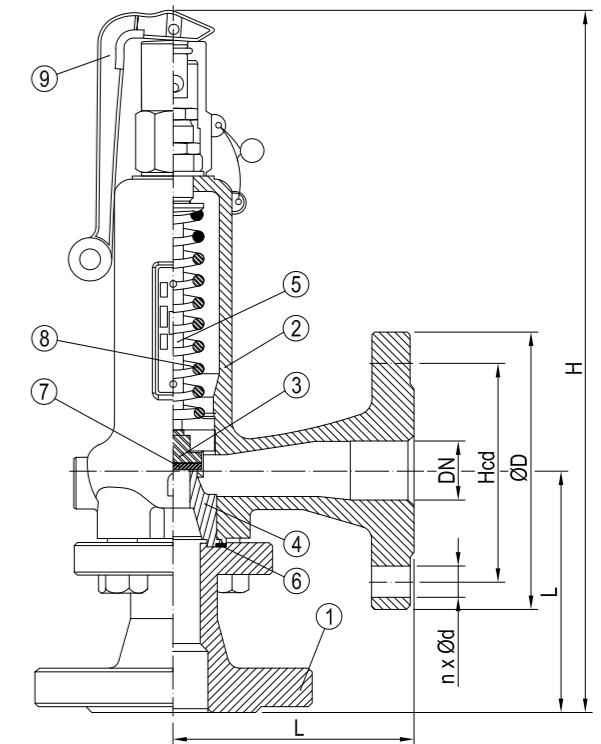



SAFETY VALVE

FULL LIFT, FLANGED ENDS

475302
PN16

DESCRIPTION: For steam, gases and hot water in pressure vessels and steam boilers. Angled nodular cast iron body metal seated safety relief valve - Full lift version. Pressure preset and sealed, fitted with manual relief handle. Raised face flanged.

APPLICATION: Prevention of over pressure in steam, gases and liquids. Typically fitted on e.g. steam boilers.

STANDARD & DESIGN:

Design Code:	-
Inspection Std.:	-
End Std.:	DIN 2533 PN16
Face to Face Std.:	-
Flanges Drilled:	PN16(DN20-DN100)
Max. set pressure:	20 bar(DN20-DN100)
Temperature range:	Up to 350°C

VARIATIONS: Other dimensions and materials on request. Available as gastight model.

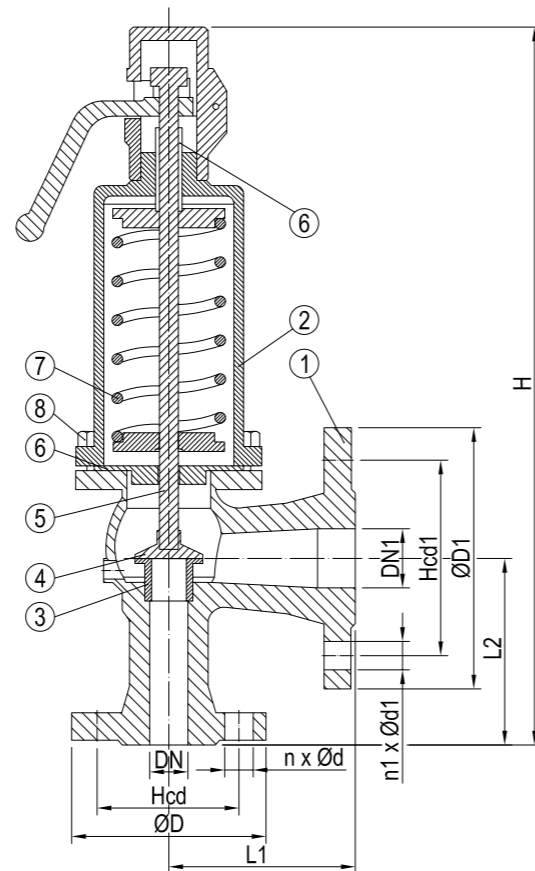
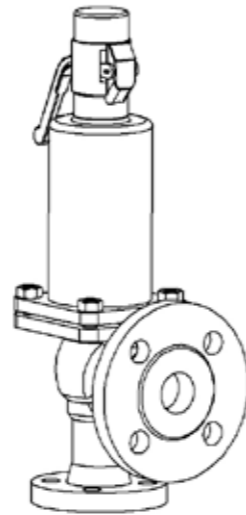

No	Part	Material	Code
1	Body	Nodular Cast Iron	EN-GJS-400-18-LT
2	Bonnet	Nodular Cast Iron	EN-GJS-400-18-LT
3	Seat	Stainless Steel	1.4021/1.4301
4	Disc	Stainless Steel	1.4305
5	Spindle	Stainless Steel	1.4021
6	Guide Bush	Stainless Steel	1.4301
7	Spring	Stainless Steel	1.4310
8	Bonnet Bolt	Stainless Steel	CK 35

DN	n x Ød	Hcd	ØD	DN1	n1 x Ød1	Hcd1	ØD1	L1	L2	H	Kg
20	4x14	75	105	32	4x18	100	140	100	100	385	10
25	4x14	85	115	40	4x18	110	150	100	105	395	12
32	4x18	100	140	50	4x18	125	165	110	115	410	15
40	4x18	110	150	65	4x18	145	185	115	140	580	24
50	4x18	125	165	80	8x18	160	200	120	150	600	26
65	4x18	145	185	100	8x18	180	220	140	170	710	46
80	8x18	160	200	125	8x18	210	250	160	195	735	50
100	8x18	180	220	150	8x22	240	285	180	220	860	72



SAFETY VALVE

THREADED ENDS

475693
PN25

DESCRIPTION: Angled AISI 316 equivalent body PTFE seated proportional safety relief valve. Pressure preset and sealed. Male BSPP inlet and female BSPP outlet.

APPLICATION: Prevention of over pressure in steam, gases and liquids. Typically fitted on e.g. steam boilers.

STANDARD & DESIGN:

Design Code:	ISO 4126-1:2004
Inspection Std.:	-
End Std.:	ISO 228/1
Face to Face Std.:	-
Pressure rating:	PN25(DN8-DN100)
Temperature Range:	-60°C to 250°C

VARIATIONS: Available with lever. Available with flanged inlet connection. Other dimensions and materials on request.

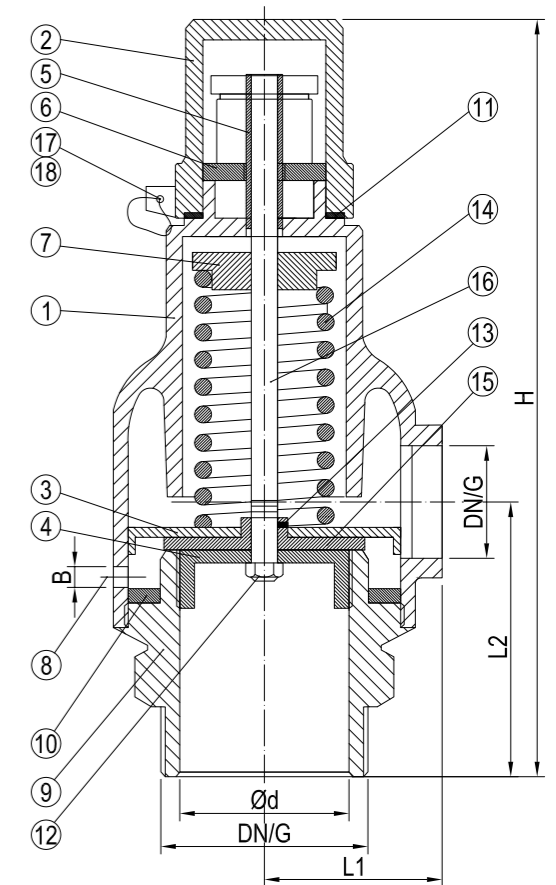
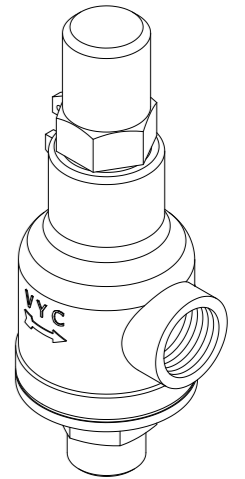

No	Part	Material	Code
1	Body	Stainless Steel	EN-1.4408
2	Cap (<=DN32)	Stainless Steel	EN-1.4305
	(>=DN40)	Stainless Steel	EN-1.4408
3	Coupling	Stainless Steel	EN-1.4401
4	Lead	Stainless Steel	EN-1.4401
5	Hollow Screw	Stainless Steel	EN-1.4305
6	Hollow Screw Nut	Stainless Steel	EN-1.4305
7	Spring Press	Stainless Steel	EN-1.4301
8	Plug (>=DN65)	Stainless Steel	EN-1.4401
9	Screwed Seat	Stainless Steel	EN-1.4408
10	Body Coupling	PTFE	-
11	Hood Coupling	PTFE	-
12	Nut	Stainless Steel	EN-1.4401
13	Clip	Stainless Steel	EN-1.4310
14	Spring	Stainless Steel	EN-1.4310
15	Sealing Disc	PTFE	-
16	Stem	Stainless Steel	EN-1.4301
17	Sealing Wire	Sealing Wire	-
18	Seal	Plastic	-

DN	G(Inch)	B(Inch)	L1	L2	H	Ød	Kg
8	1/4	-	30	43	129	10.2	0.5
10	3/8	-	30	43	129	10.2	0.5
15	1/2	-	32	52	140	16.2	0.6
20	3/4	-	35	61	158	20.8	0.8
25	1	-	38	72	181	25.2	1.2
32	1 1/4	-	44	80	212	32.2	1.8
40	1 1/2	-	55	91	247	38.2	3.0
50	2	-	70	110	315	45.2	5.3
65	2 1/2	1/8	75	125	349	60.2	6.0
80	3	1/8	90	136	415	75.2	8.7
100	4	1/8	105	163	483	95.2	24.0



RELIEF VALVE

THREADED ENDS

479102

DESCRIPTION: Angled nodular cast iron body metal seated safety relief valve. Pressure preset and sealed, fitted with manual relief handle. Male BSPP inlet and female BSPP outlet.

APPLICATION: Prevention of over pressure in steam, gases and liquids. Typically fitted on e.g. steam boilers. Also often used in starting air system.

STANDARD & DESIGN:

Design Code:	-
Inspection Std.:	-
End Std.:	DIN ISO 228
Face to Face Std.:	-
Max. set pressure:	200 bar(DN15-DN25) 130 bar(DN32) 45 bar(DN40-DN50)
Temperature Range:	-10°C to 280°C

VARIATIONS: Other dimensions and materials on request.

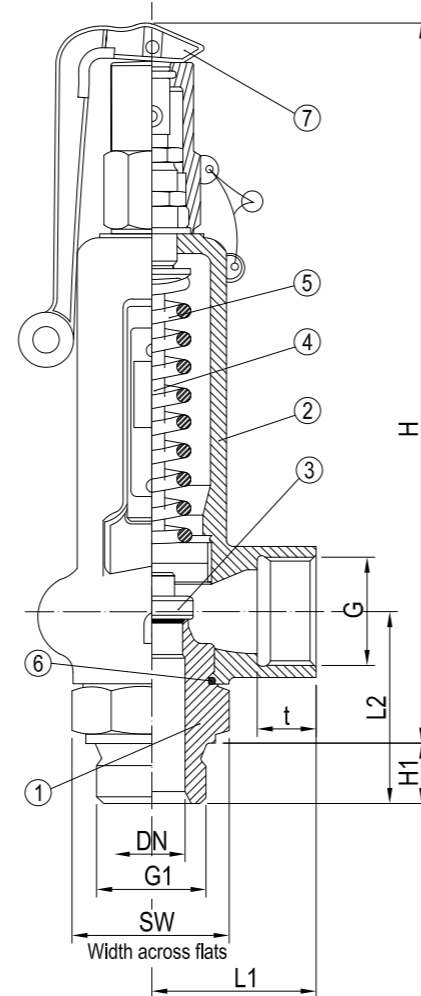
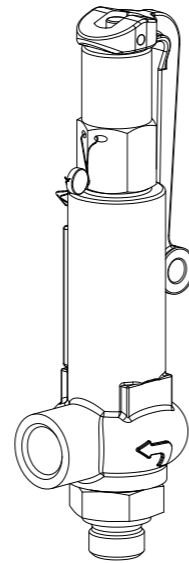

No	Part	Material	Code
1	Body	Stainless Steel	1.4104
2	Spring Bonnet	Nodular Cast Iron	0.7043
3	Disc	Stainless Steel	1.4571
4	Stem	Stainless Steel	1.4104
5	Spring	Stainless Steel	1.4310
6	O-Ring	NBR	-
7	Lifting Lever	Aluminium	3.2581

DN	G1(inch)	G(inch)	L1	L2	H	H1	t	SW	Kg
15	1/2	1/2	50	40	230	14	17	41	1.6
20	3/4	3/4	50	40	230	14	17	41	1.6
25	1	1	50	40	230	18	17	41	1.6
32	1 1/4	1	50	40	230	18	17	50	1.8
40	1 1/2	1	50	40	230	19	17	55	1.8
50	2	1	50	40	230	20	17	60	1.8



RELIEF VALVE

THREADED ENDS

479192

DESCRIPTION: Angled stainless steel body metal seated safety relief valve. Pressure preset and sealed, fitted with manual relief handle. Male BSPP inlet and female BSPP outlet.

APPLICATION: Prevention of over pressure in steam, gases and liquids. Typically fitted on e.g. steam boilers. Also often used in starting air system.

STANDARD & DESIGN:

Design Code:	-
Inspection Std.:	-
End Std.:	DIN ISO 228
Face to Face Std.:	-
Max. set pressure:	500 bar(DN15-DN25) 130 bar(DN32) 45 bar(DN40-DN50)
Temperature Range:	-60°C to 280°C

VARIATIONS: Other dimensions and materials on request.

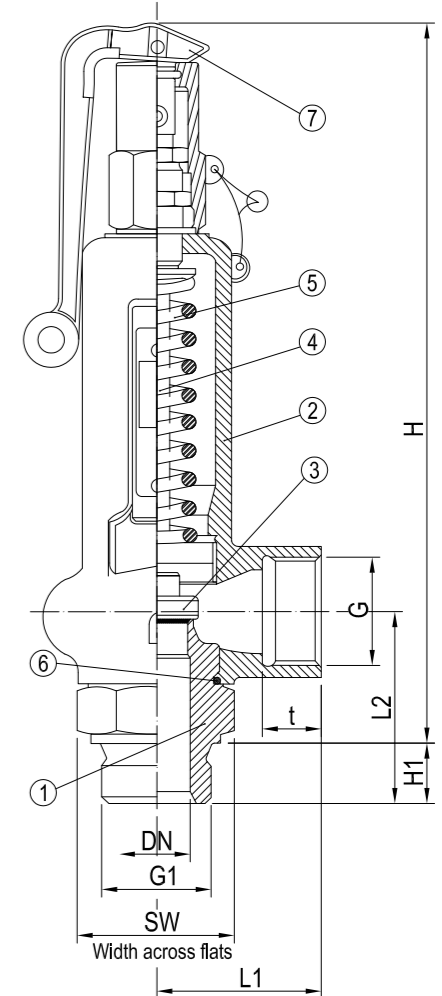
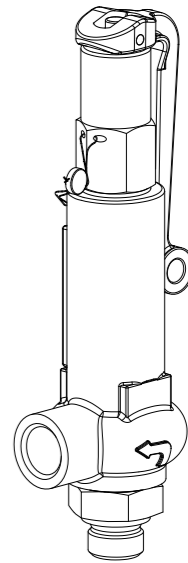

No	Part	Material	Code
1	Body	Stainless Steel	1.4571
2	Spring Bonnet	Stainless Steel	1.4581
3	Disc	Stainless Steel	1.4571
4	Stem	Stainless Steel	1.4571
5	Spring	Stainless Steel	1.4310
6	O-Ring	FPM	-
7	Lifting Lever	Aluminium	3.2581

DN	G1(inch)	G(inch)	L1	L2	H	H1	t	SW	Kg
15	1/2	1/2	50	40	230	14	17	41	1.6
20	3/4	3/4	50	40	230	14	17	41	1.6
25	1	1	50	40	230	18	17	41	1.6
32	1 1/4	1	50	40	230	18	17	50	1.8
40	1 1/2	1	50	40	230	19	17	55	1.8
50	2	1	50	40	230	20	17	60	1.8



QUICK CLOSING & SELF CLOSING VALVES

Self closing valves with spring or weight operation secure that the valves always returns to closed position. Available in straight or angle pattern. Quick closing valves operated by mechanical, pneumatic or hydraulic impulse. Available in straight or angle pattern. Float valves delivered with floating bouy which open or closes the valve depending on the level in a tank. Available in straight or angle pattern and in threaded or flanged connection.



FLOAT VALVE

THREADED ENDS

312891
PN10

DESCRIPTION: Full AISI 316 float valve with BSPP thread inlet.

APPLICATION: Cooling towers, Feedwaters tanks, Pasteurizers. Used for keeping a certain minimum fluid level in tanks etc.

STANDARD & DESIGN:

Design Code: -
 Inspection Std.: -
 End Std.: BSP
 Face to Face Std.: -
 Pressure rating: PN10(DN15-DN80)
 Temperature range: Up to 150°C

VARIATIONS: With flange.

Other dimensions and materials on request.

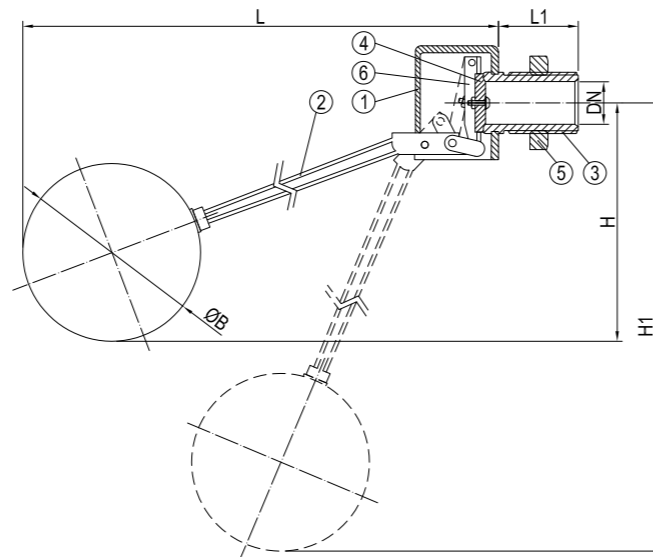
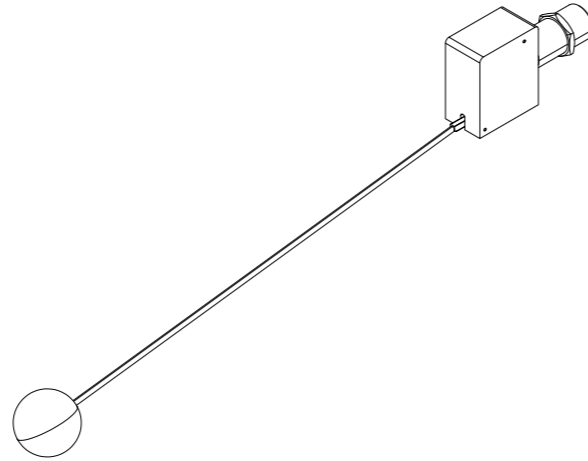

No	Part	Material	Code
1	Body	Stainless Steel	AISI-316
2	Stem	Stainless Steel	AISI-316
3	Coupling	Stainless Steel	AISI-316
4	Seal	Silicone	-
5	Nut	Stainless Steel	AISI-316
6	Lever	Stainless Steel	AISI-316

DN	Inch	L	L1	H	H1	ØB	Kg
15	1/2	410	35	127/180	375	110	0.5
20	3/4	490	42	155/197	436	160	0.9
25	1	585	45	174/220	521	160	0.9
32	1 1/4	585	52	164/222	520	160	1.3
40	1 1/2	710	60	253/318	651	200	3.6
50	2	798	70	255/324	736	200	3.9
65	2 1/2	1058	80	277/390	737	200	4.8
80	3	1447	170	310/493	1248	300	18.6



FLUSHING VALVE

THREADED ENDS

314022
PN16

DESCRIPTION: Straight type Rg5 body, spring loaded, self closing flushing valve. BSPP female thread.

APPLICATION: Used where liquids should be instantaneously available. For drainage of slurries, solid or semi solid particles etc.

STANDARD & DESIGN:

Design Code: -
 Inspection Std.: EN 12516-3t
 End Std.: UNI ISO 228-1:2003
 Face to Face Std.: -
 Pressure rating: PN16(DN15-DN50)
 Temperature range: -10°C to +180°C

VARIATIONS: Other dimensions and materials on request.

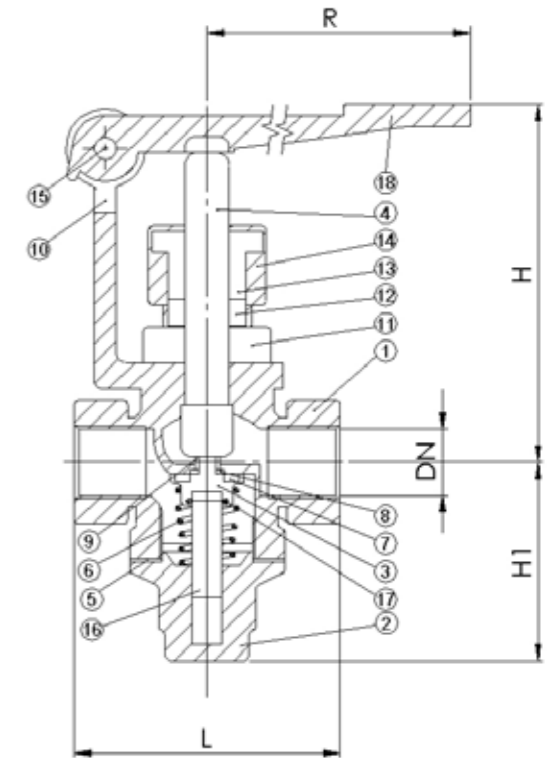
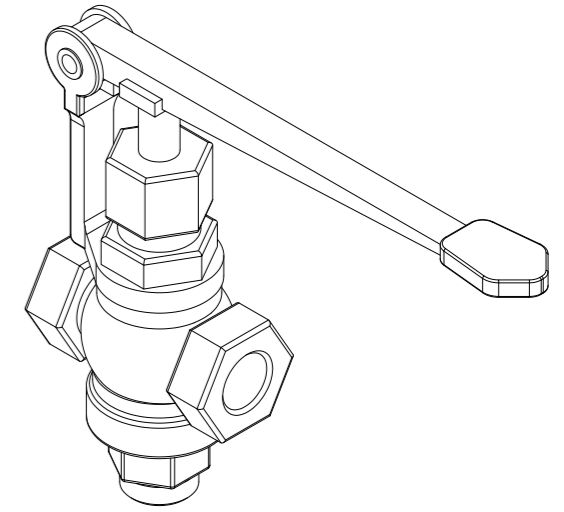

No	Part	Material	Code
1	Body	Bronze	CC491 K
2	Bonnet	Brass	CW614-N
3	Disc	Brass	CW614-N
4	Stem	Brass	CW614-N
5	Gasket	Asbestos Free	SIL C4400
6	Self Closing Spring	Stainless Steel	-
7	Gasket	PTFE	-
8	Washer	Brass	CW614-N
9	Nut	Brass	CW614-N
10	Support	Brass	CW614-N
11	Nut	Brass	CW614-N
12	Packing	Fiber	AF15/MA
13	Gland Packing	Brass	CW614-N
14	Gland Nut	Brass	CW614-N
15	Pin	Adciaio Inox	-
16	Check Valve Stem	Brass	CW614-N
17	Fixing Ring	Adciaio Inox	-
18	Lever	Brass	CW614-N

DN	Inch	L	H	H1	R	Kg
15	1/2	60	111	45	130	0.8
20	3/4	70	142	48	130	0.9
25	1	80	84	55	130	1.6
32	1 1/4	96	-	59	160	1.6
40	1 1/2	104	-	67	160	1.9
50	2	130	-	79	160	2.9



SOUNDING COCK

THREADED ENDS

357020
PN2.5

DESCRIPTION: Rg5 manual sounding cock with cap and lever with counterweight. Female BSP threaded connection to sounding pipe.

APPLICATION: Easy sounding access to ships double bottom tanks requiring manual sounding option etc.

STANDARD & DESIGN:

Design Code: -
 Inspection Std.: -
 End Std.: BSP
 Face to Face Std.: -
 Pressure rating: PN2.5(DN32-DN50)

VARIATIONS: With foot pedal.
 Other dimensions and materials on request.

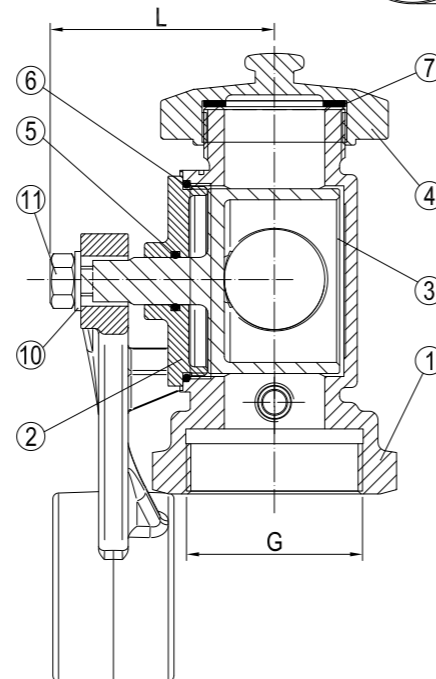
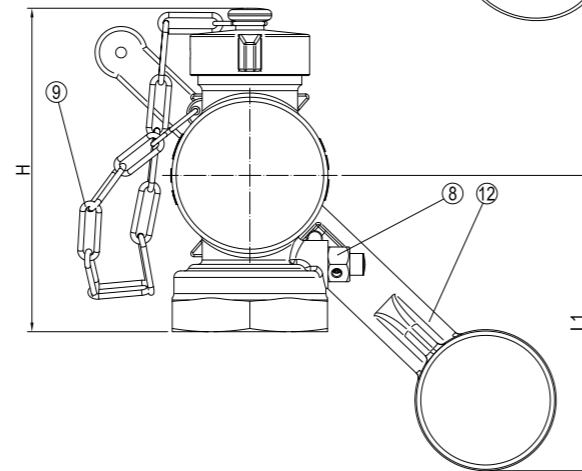
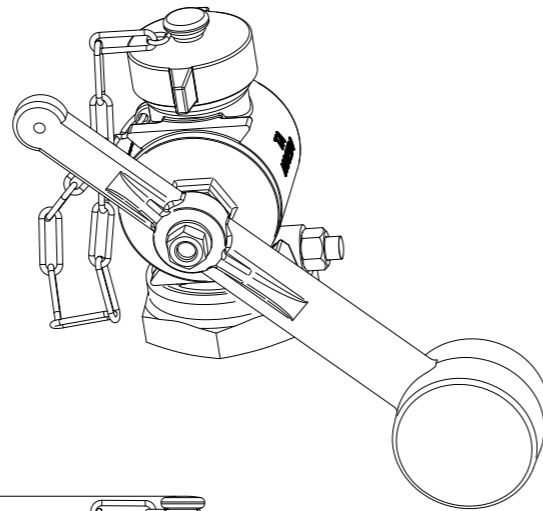

No	Part	Material	Code
1	Body	Bronze	CC491 K
2	Bonnet	Bronze	CC491 K
3	Plug	Bronze	CC491 K
4	Cap	Bronze	CC491 K
5	O-Ring	NBR	-
6	O-Ring	NBR	-
7	Cap Gasket	NBR	-
8	Vacuum Valve	Brass	CW602 N
9	Chain	Steel	-
10	Washer	Stainless Steel	EN 1.4404
11	Nut	Stainless Steel	EN 1.4404
12	Lever	Cast Iron	EN JL1040

DN	G(Inch)	L	L1	H	Kg
32	1 1/4	75	145	151	3.5
40	1 1/2	75	145	151	3.5
50	2	75	145	151	3.5



SELF CLOSING VALVE

357321
PN10

DESCRIPTION: Rg5 self closing valve for connection to tank bulkhead and sight glass. Flat face flange towards tank, BSPP female fitting of sight glass.

APPLICATION: For manual level control of e.g. ships viny tanks etc.

STANDARD & DESIGN:

Design Code: -
 Inspection Std.: -
 End Std.: BSP
 Face to Face Std.: -
 Flanges Drilled: PN10(DN20-DN25)
 Pressure rating: PN10(DN20-DN25)

VARIATIONS: With drainpipe
 Other dimensions and materials on request.

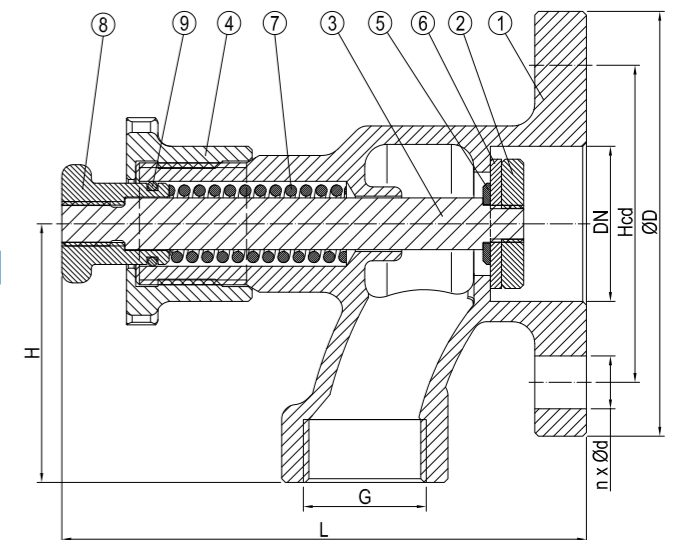
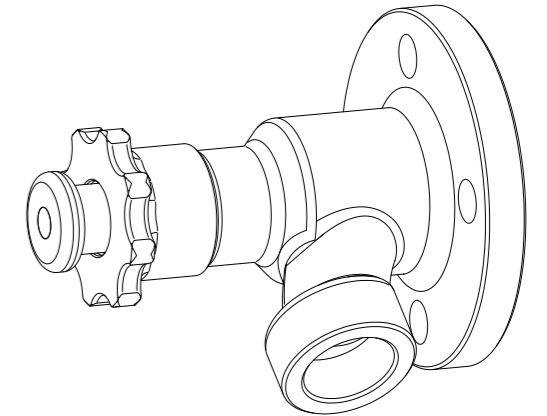

No	Part	Material	Code
1	Body	Bronze	CC491 K
2	Disc	Brass	CW602 N
3	Stem	Brass	CW602 N
4	Locking Nut	Bronze	CC491 K
5	Washer	Brass	CW602 N
6	Disc Packing	NBR	-
7	Spring	Stainless Steel	EN 1.4001
8	Push Button	Brass	CW602 N
9	O-Ring	NBR	-

DN	n x ød	Hcd	øD	G	L	H	Kg
20	4x14	75	105	1"	145	70	2.3
25	4x14	85	115	1"	145	75	2.7



SELF CLOSING VALVE

357692
PN16

DESCRIPTION: AISI 316L self closing valve for connection to tank bulkhead and sight glass. BSPP male towards tank, BSPP female towards sight glass.

APPLICATION: For manual level control of e.g. ships viny tanks etc.

STANDARD & DESIGN:

Design Code: -
 Inspection Std.: -
 End Std.: BSP
 Face to Face Std.: -
 Pressure rating: PN16(DN15-DN25)

VARIATIONS: Other dimensions and materials on request.

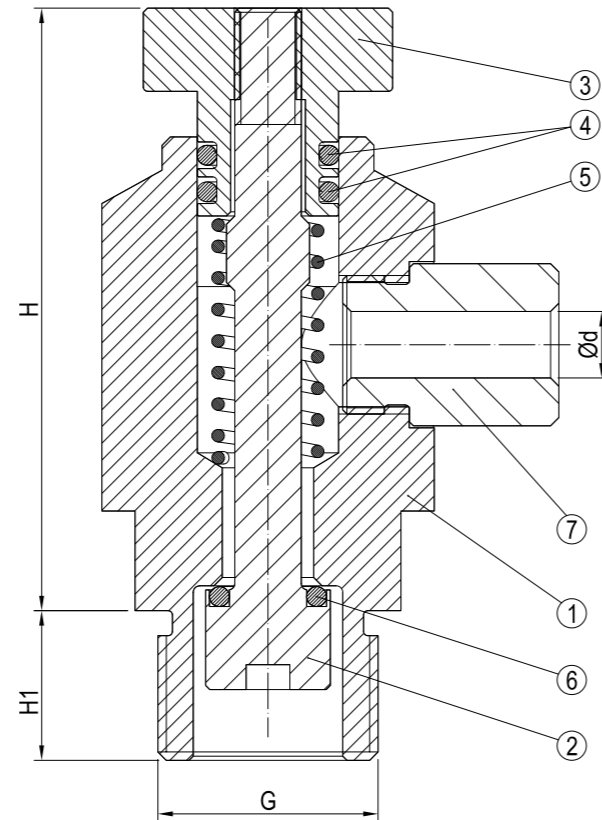
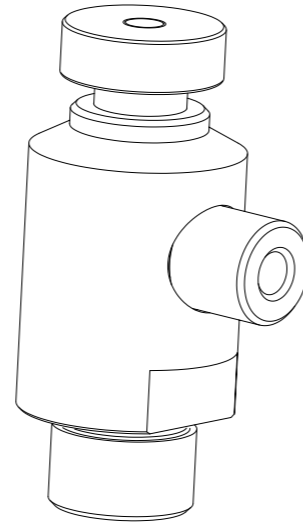

No	Part	Material	Code
1	Body	Stainless Steel	EN 1.4404
2	Stem	Stainless Steel	EN 1.4404
3	Push Button	Stainless Steel	EN 1.4404
4	O-Ring	Viton	-
5	Spring	Stainless Steel	EN 1.4001
6	O-Ring	Viton	-
7	Drain Pipe	Stainless Steel	EN 1.4404

DN	G(Inch)	H	H1	Ød	Kg
15	1/2"	60	12	8	0.3
20	3/4"	70	18	10	0.6
25	1"	87	24	12	0.8



SELF CLOSING VALVE

STRAIGHT TYPE, FLANGED ENDS

358002
PN16

DESCRIPTION: Straight type nodular cast iron, metal seated, self closing globe valve. Bolted bonnet and lever with counter weight. Raised face flanged.

APPLICATION:

Quick Start/stop of: Water and low pressure steam, oils etc.

STANDARD & DESIGN:

Design Code: Body: DIN 86251, bonnet: with counter weight.
 Inspection Std.: -
 End Std.: EN 1092/B (DIN 2501)
 Face to Face Std.: EN 558 Series 1 (DIN 3202 F1)
 Flanges drilled: PN16 (DN15-DN100)
 Pressure rating: PN16 (DN15-DN100)
 Temperature range: -10°C to +120°C

VARIATIONS: Anti clockwise closing.
 Bronze trim

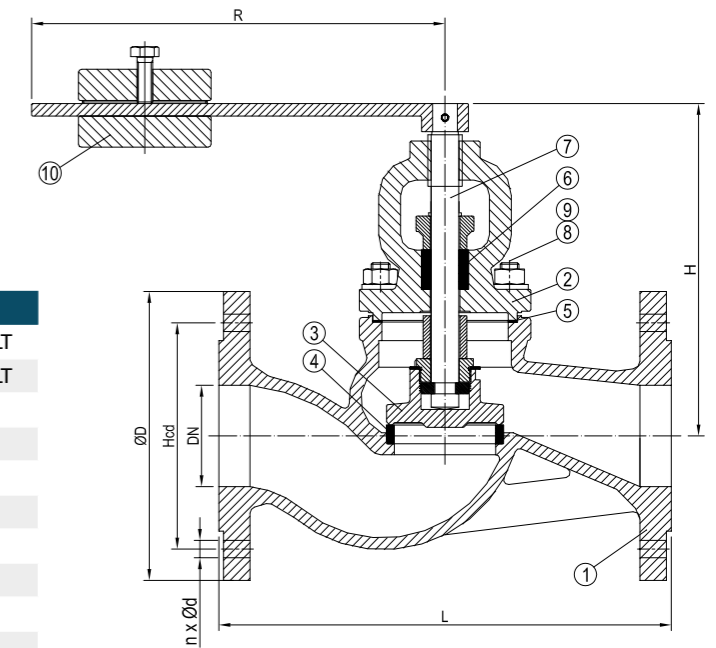
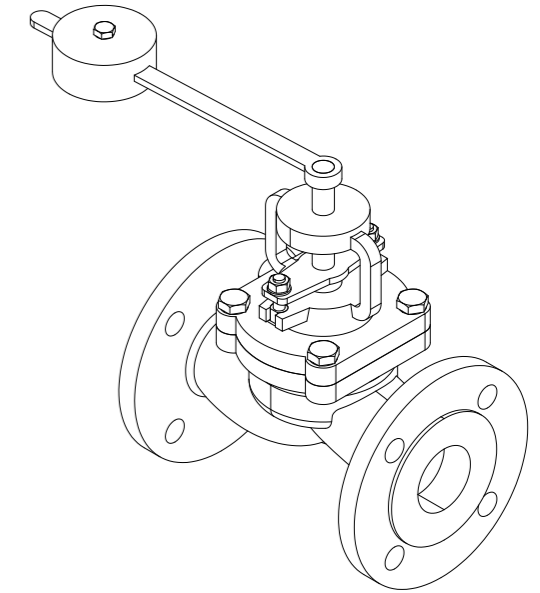

No	Part	Material	Code
1	Body	Nodular Cast Iron	EN-GJS400-18-LT
2	Bonnet	Nodular Cast Iron	EN-GJS400-18-LT
3	Disc	Stainless Steel	AISI420
4	Body Seat	Stainless Steel	AISI304
5	Bonnet Gasket	Graphite	-
6	Gland Packing	Graphite	-
7	Stem	Stainless Steel	AISI420
8	Stud Bolt	Steel	-
9	Nut	Steel	-
10	Lever&Counter Weight	Steel	St37

DN	n x Ød	Hcd	ØD	L	H	R	Kg
15	4x14	65	95	130	160	245	3
20	4x14	75	105	150	160	245	6
25	4x14	85	115	160	170	245	7
32	4x18	100	140	180	170	245	8
40	4x18	110	150	200	210	295	13
50	4x18	125	165	230	220	295	15
65	4x18	145	185	290	225	295	21
80	8x18	160	200	310	270	295	28
100	8x18	180	220	350	280	295	40



SELF CLOSING VALVE

STRAIGHT TYPE, FLANGED ENDS

358052
PN16

DESCRIPTION: Straight type grey cast iron, metal seated, self closing globe valve. Bolted bonnet and lever with counter weight. Raised face flanged.

APPLICATION:

For hot and cold and water and oil.
Quick Start/stop of: Water and oils etc.

STANDARD & DESIGN:

Design Code: Body: DIN 86251, bonnet: with counter weight.
Inspection Std.: -
End Std.: EN 1092/B (DIN 2501)
Face to Face Std.: EN 558 Series 1 (DIN 3202 F1)
Flanges drilled: PN16 (DN15-DN100)
Pressure rating: PN16 (DN15-DN100)
Temperature range: -10°C to +180°C

VARIATIONS: Anti clockwise closing.
Bronze trim

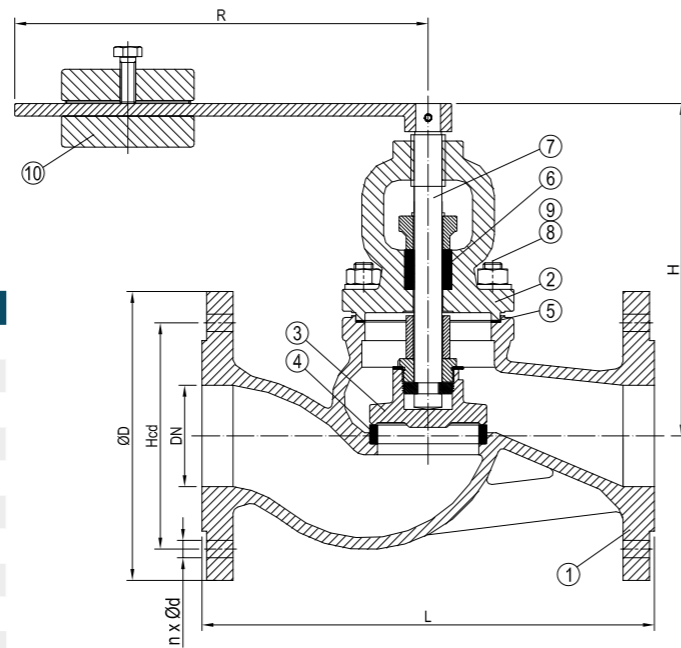
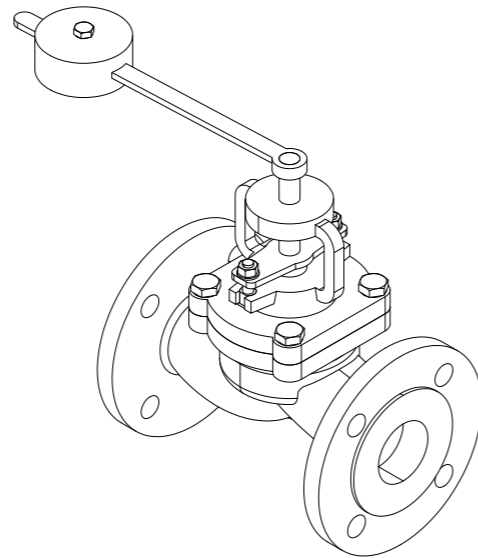

No	Part	Material	Code
1	Body	Cast Iron	EN-GJL250
2	Bonnet	Cast Iron	EN-GJL250
3	Disc	Stainless Steel	AISI 420
4	Body Seat	Stainless Steel	AISI 304
5	Bonnet Gasket	Graphite	-
6	Gland Packing	Graphite	-
7	Stem	Stainless Steel	AISI420
8	Stud Bolt	Steel	-
9	Nut	Steel	-
10	Lever&Counter Weight	Steel	St37

DN	n x ød	Hcd	øD	L	H	R	Kg
15	4x14	65	95	130	160	245	3
20	4x14	75	105	150	160	245	6
25	4x14	85	115	160	170	245	7
32	4x18	100	140	180	170	245	8
40	4x18	110	150	200	210	295	13
50	4x18	125	165	230	220	295	15
65	4x18	145	185	290	225	295	21
80	8x18	160	200	310	270	295	28
100	8x18	180	220	350	280	295	40



QUICK CLOSING VALVE

STRAIGHT TYPE, FLANGED ENDS

567002/01
PN16/PN10

DESCRIPTION: Straight type nodular cast iron, metal seated, quick closing globe valve. Release cylinder for pneumatic, hydraulic or mechanical remote control. Raised face flanged.

APPLICATION: Remote emergency shut off valve for fuels, oils and other combustible liquids. Engine room installation etc.

STANDARD & DESIGN:

Design Code: -
Inspection Std.: -
End Std.: EN 1092/B (DIN 2501)
Face to Face Std.: EN 558 Series 1 (DIN 3202 F1)
Flanges drilled: PN16 (DN15-DN150)
PN10 (DN200)
Pressure rating: PN16 (DN15-DN150)
PN10 (DN200)
Temperature range: -10°C to +150°C

VARIATIONS: Other dimensions and materials on request.
Impuls unit for remote control.

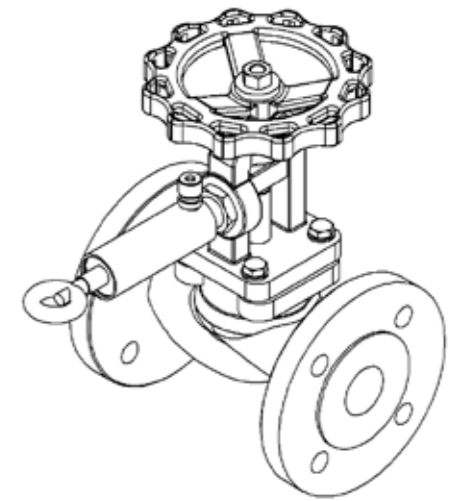

Pressure & Temperature ranges:

Bore	Working Pressure(Bar)	
	150°C	
DN15-DN150	16	
DN200	10	

No	Part	Material	Code
1	Body	Nodular Cast Iron	EN-GJS400-18-LT
2	Bonnet	Nodular Cast Iron	EN-GJS400-18-LT
3	Disc	Stainless Steel	X20Cr13(1.4021)
4	Seat	Stainless Steel	AISI 304(1.4301)
5	Stem	Stainless Steel	X20Cr13(1.4021)
6	Spring	Spring Steel	1.4310
7	Bonnet Gasket	Graphite	-
8	Retainer Block	Brass	CuZn39Pb3
9	Stud Bolt	Steel	-
10	Nut	Steel	-
11	Cylinder	Brass	CuZn39Pb3
12	Handwheel	Cast Iron	EN-GJL250

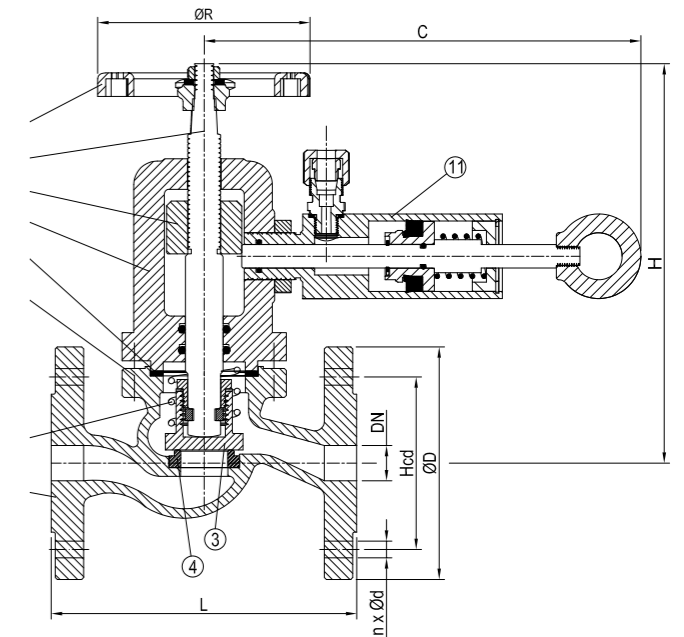

DN	n x ød	Hcd	øD	L	H	øR	C	Kg
15	4x14	65	95	130	175	120	190	4.0
20	4x14	75	105	150	175	120	190	4.5
25	4x14	85	115	160	190	140	190	5.0
32	4x18	100	140	180	190	140	190	7.0
40	4x18	110	150	200	205	160	195	11.0
50	4x18	125	165	230	215	160	195	13.0
65	4x18	145	185	290	245	180	195	19.0
80	8x18	160	200	310	270	200	195	25.0
100	8x18	180	220	350	305	225	195	35.0
125	8x18	210	250	400	330	250	195	55.0
150	8x22	240	285	480	380	300	195	75.0
200	8x22	295	340	600	450	400	195	135.0



QUICK CLOSING VALVE

STRAIGHT TYPE, FLANGED ENDS

567022/21
PN16/PN10

DESCRIPTION: Straight type Rg5, metal seated, quick closing globe valve. Release cylinder for pneumatic, hydraulic or mechanical remote control. Raised face flanged.

APPLICATION: Remote emergency shut off valve for fuels, oils and other combustible liquids. Engine room installation etc.

STANDARD & DESIGN:

Design Code: Body: DIN 86260, bonnet: with release cylinder
Inspection Std.: -
End Std.: EN 1092-3/B (DIN 2501)
Face to Face Std.: EN 558 series 1 (DIN 3202 F1)
Flanges drilled: PN16 (DN15-DN150)
PN10 (DN200)
Pressure rating: PN16 (DN15-DN150)
PN10 (DN200)
Temperature range: -10°C to +150°C

VARIATIONS: Other dimensions and materials on request.
Impuls unit for remote control.

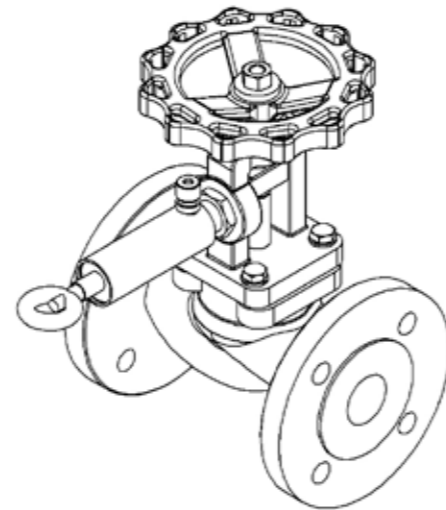

Pressure & Temperature ranges:

Bore	Working Pressure(Bar)	
	150°C	
DN15-DN150	16	
DN200	10	

No	Part	Material	Code
1	Body	Bronze	CuSn5Zn5Pb5-C
2	Bonnet	Bronze	CuSn5Zn5Pb5-C
3	Disc	Stainless Steel	AISI 304(1.4301)
4	Seat	Stainless Steel	AISI 304(1.4301)
5	Stem	Stainless Steel	AISI 304(1.4301)
6	Spring	Stainless Steel	1.4310
7	Bonnet Gasket	Graphite	-
8	Retainer Block	Brass	CuZn39Pb3
9	Stud Bolt	Stainless Steel	A2 (AISI 304)
10	Nut	Stainless Steel	A2 (AISI 304)
11	Cylinder	Brass	CuZn39Pb3
12	Handwheel	Cast Iron	EN-GJL250

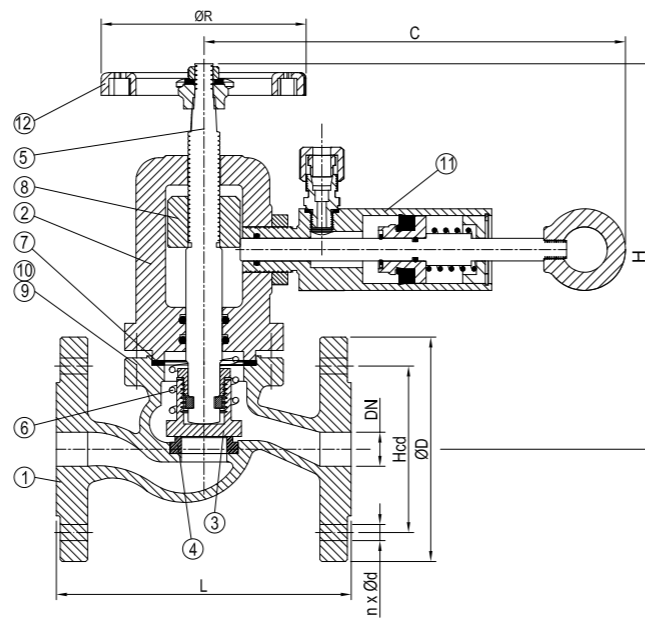

DN	n x ød	Hcd	øD	L	H	øR	C	Kg
15	4x14	65	95	130	175	120	190	4.0
20	4x14	75	105	150	175	120	190	4.5
25	4x14	85	115	160	190	140	190	6.0
32	4x18	100	140	180	190	140	190	8.0
40	4x18	110	150	200	205	160	195	12.0
50	4x18	125	165	230	215	160	195	14.0
65	4x18	145	185	290	245	180	195	20.0
80	8x18	160	200	310	270	200	195	26.0
100	8x18	180	220	350	305	225	195	36.0
125	8x18	210	250	400	330	250	195	58.0
150	8x22	240	285	480	380	300	195	75.0
200	8x22	295	340	600	450	400	195	145.0



QUICK CLOSING VALVE

STRAIGHT TYPE, FLANGED ENDS

567062/61
PN16/PN10

DESCRIPTION: Straight type cast steel, metal seated, quick closing globe valve. Release cylinder for pneumatic, hydraulic or mechanical remote control. Raised face flanged.

APPLICATION: Remote emergency shut off valve for fuels, oils and other combustible liquids. Engine room installation etc.

STANDARD & DESIGN:

Design Code: -
Inspection Std.: -
End Std.: EN 1092/B (DIN 2501)
Face to Face Std.: EN 558 series 1 (DIN 3202 F1)
Flanges drilled: PN16 (DN15-DN150)
PN10 (DN200)
Pressure rating: PN16 (DN15-DN150)
PN10 (DN200)
Temperature range: -10°C to +150°C

VARIATIONS: Other dimensions and materials on request.
Impuls unit for remote control.

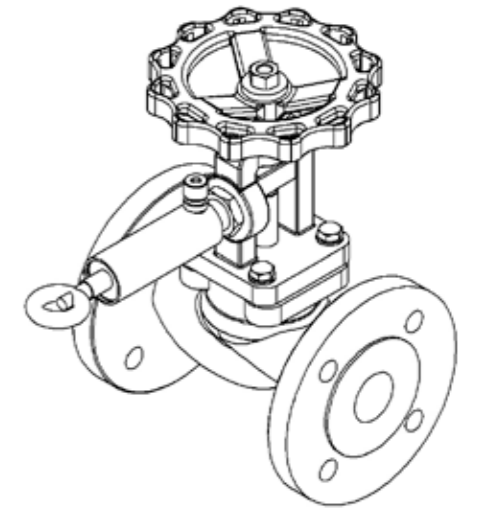

Pressure & Temperature ranges:

Bore	Working Pressure(Bar)	
	150°C	
DN15-DN150	16	
DN200	10	

No	Part	Material	Code
1	Body	Cast Steel	GP240GH
2	Bonnet	Cast Steel	GP240GH
3	Disc	Stainless Steel	X20Cr13(1.4021)
4	Seat	Stainless Steel	AISI304(1.4301)
5	Stem	Stainless Steel	X20Cr13(1.4021)
6	Spring	Spring Steel	1.4310
7	Bonnet Gasket	Graphite	-
8	Retainer Block	Brass	CuZn39Pb3
9	Stud Bolt	Steel	-
10	Nut	Steel	-
11	Cylinder	Brass	CuZn39Pb3
12	Handwheel	Cast Iron	EN-GJL250

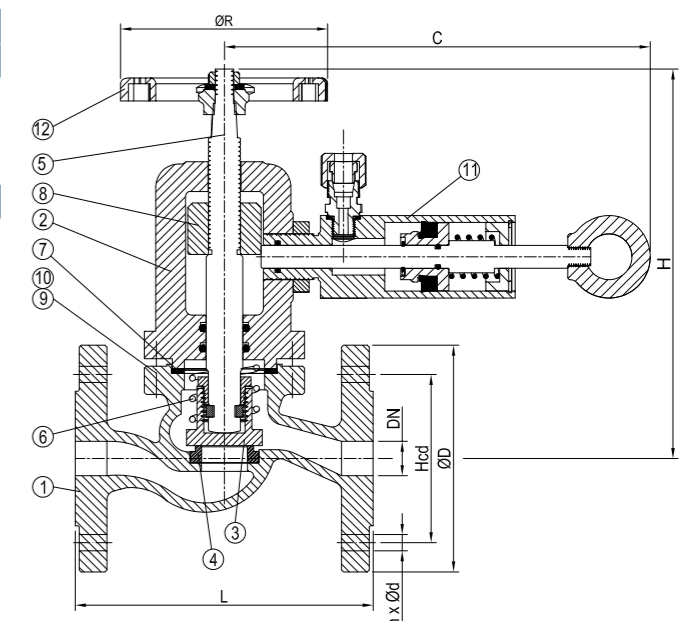

DN	n x ød	Hcd	øD	L	H	øR	C	Kg
15	4x14	65	95	130	175	120	190	4.0
20	4x14	75	105	150	175	120	190	4.5
25	4x14	85	115	160	190	140	190	5.0
32	4x18	100	140	180	190	140	190	7.0
40	4x18	110	150	200	205	160	195	11.0
50	4x18	125	165	230	215	160	195	13.0
65	4x18	145	185	290	245	180	195	19.0
80	8x18	160	200	310	270	200	195	25.0
100	8x18	180	220	350	305	225	195	35.0
125	8x18	210	250	400	330	250	195	55.0
150	8x22	240	285	480	380	300	195	75.0
200	8x22	295	340	600	450	400	195	135.0



QUICK CLOSING VALVE

ANGLE TYPE, FLANGED ENDS

567102/01
PN16/PN10

DESCRIPTION: Angled type nodular cast iron, metal seated, quick closing globe valve. Release cylinder for pneumatic, hydraulic or mechanical remote control. Raised face flanged.

APPLICATION: Remote emergency shut off valve for fuels, oils and other combustible liquids. Engine room installation etc.

STANDARD & DESIGN:

Design Code: -
 Inspection Std.: -
 End Std.: EN 1092/B (DIN 2501)
 Face to Face Std.: EN 558 Series 8 (DIN 3202 F32)
 Flanges drilled: PN16 (DN15-DN150)
 PN10 (DN200)
 Pressure rating: PN16 (DN15-DN150)
 PN10 (DN200)
 Temperature range: -10°C to +150°C

VARIATIONS: Other dimensions and materials on request. Impuls unit for remote control.

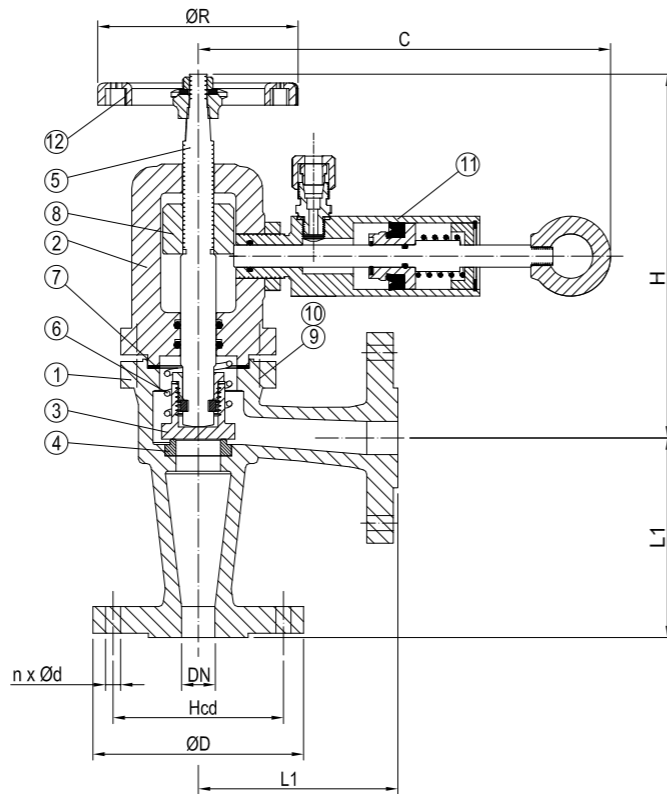
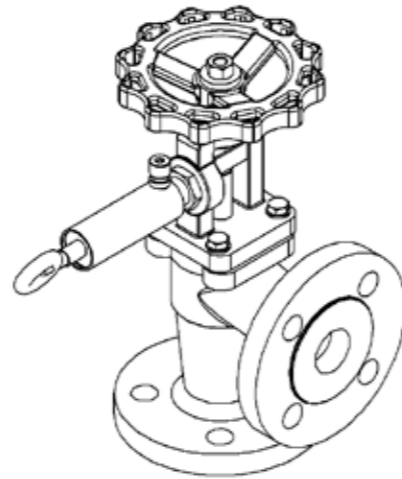

Pressure & Temperature ranges:

Bore	Working Pressure(Bar)	
	150°C	
DN15-DN150	16	
DN200	10	

No	Part	Material	Code
1	Body	Nodular Cast Iron	EN-GJS400-18-LT
2	Bonnet	Nodular Cast Iron	EN-GJS400-18-LT
3	Disc	Stainless Steel	X20Cr13(1.4021)
4	Seat	Stainless Steel	AISI 304(1.4301)
5	Stem	Stainless Steel	X20Cr13(1.4021)
6	Spring	Spring Steel	1.4310
7	Bonnet Gasket	Graphite	-
8	Retainer Block	Brass	CuZn39Pb3
9	Stud Bolt	Steel	-
10	Nut	Steel	-
11	Cylinder	Brass	CuZn39Pb3
12	Handwheel	Cast Iron	EN-GJL250

DN	n x ød	Hcd	øD	L1	H	øR	C	Kg
15	4x14	65	95	90	170	120	190	3.8
20	4x14	75	105	95	170	120	190	4.0
25	4x14	85	115	100	180	140	190	5.0
32	4x18	100	140	105	180	140	190	7.0
40	4x18	110	150	115	200	160	195	10.0
50	4x18	125	165	125	200	160	195	12.0
65	4x18	145	185	145	225	180	195	17.0
80	8x18	160	200	155	245	200	195	23.0
100	8x18	180	220	175	275	225	195	33.0
125	8x18	210	250	200	275	250	195	50.0
150	8x22	240	285	225	315	300	195	70.0
200	8x22	295	340	275	360	400	195	110.0



QUICK CLOSING VALVE

ANGLE TYPE, FLANGED ENDS

567122/21
PN16/PN10

DESCRIPTION: Angled type Rg5, metal seated, quick closing globe valve. Release cylinder for pneumatic, hydraulic or mechanical remote control. Raised face flanged.

APPLICATION: Remote emergency shut off valve for fuels, oils and other combustible liquids. Engine room installation etc.

STANDARD & DESIGN:

Design Code: Body: DIN 86260, bonnet: with release cylinder
 Inspection Std.: -
 End Std.: EN 1092-3/B (DIN 2501)
 Face to Face Std.: EN 558 series 8 (DIN 3202 F32)
 Flanges drilled: PN16 (DN15-DN150)
 PN10 (DN200)
 Pressure rating: PN16 (DN15-DN150)
 PN10 (DN200)
 Temperature range: -10°C to +150°C

VARIATIONS: Other dimensions and materials on request. Impuls unit for remote control.

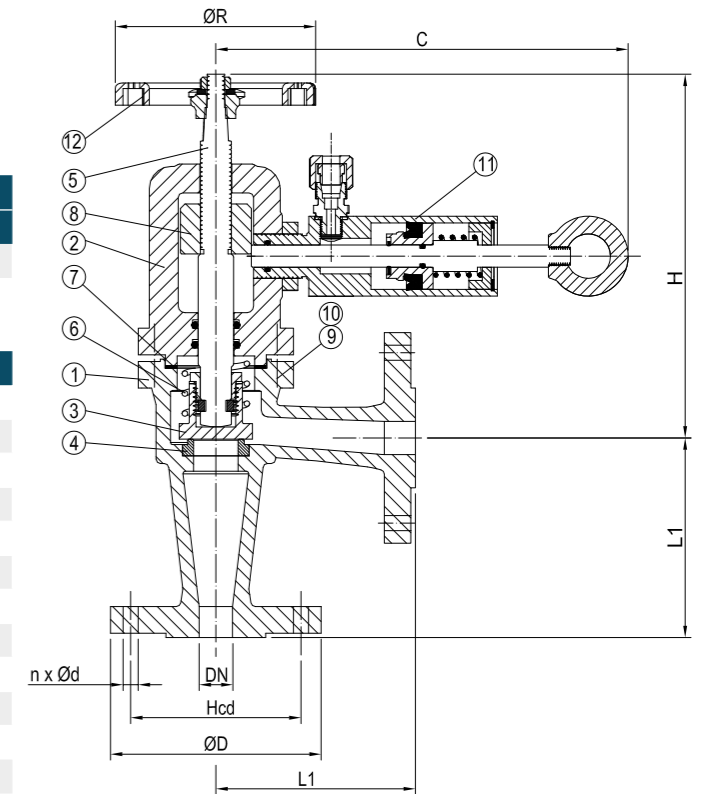
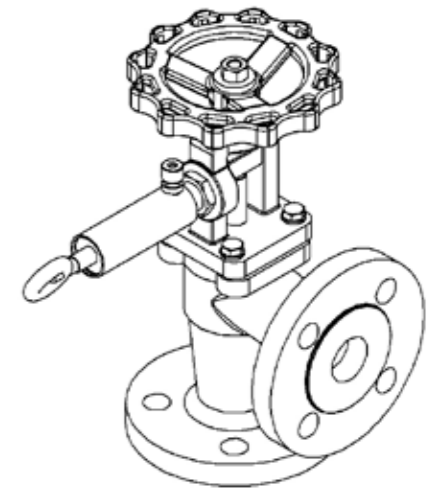

Pressure & Temperature ranges:

Bore	Working Pressure(Bar)	
	150°C	
DN15-DN150	16	
DN200	10	

No	Part	Material	Code
1	Body	Bronze	CuSn5ZnPb5-C
2	Bonnet	Bronze	CuSn5ZnPb5-C
3	Disc	Stainless Steel	AISI 304(1.4301)
4	Seat	Stainless Steel	AISI 304(1.4301)
5	Stem	Stainless Steel	AISI 304(1.4301)
6	Spring	Stainless Steel	1.4310
7	Bonnet Gasket	Graphite	-
8	Retainer Block	Brass	CuZn39Pb3
9	Stud Bolt	Stainless Steel	A2 (AISI 304)
10	Nut	Stainless Steel	A2 (AISI 304)
11	Cylinder	Brass	CuZn39Pb3
12	Handwheel	Cast Iron	EN-GJL250

DN	n x ød	Hcd	øD	L1	H	øR	C	Kg
15	4x14	65	95	90	170	120	190	4.0
20	4x14	75	105	95	170	120	190	4.5
25	4x14	85	115	100	180	140	190	6.0
32	4x18	100	140	105	180	140	190	9.0
40	4x18	110	150	115	200	160	195	12.0
50	4x18	125	165	125	200	160	195	14.0
65	4x18	145	185	145	225	180	195	19.0
80	8x18	160	200	155	245	200	195	25.0
100	8x18	180	220	175	275	225	195	32.0
125	8x18	210	250	200	275	250	195	55.0
150	8x22	240	285	225	315	300	195	70.0
200	8x22	295	340	275	360	400	195	130.0



QUICK CLOSING VALVE

567162/61
PN16/PN10

ANGLE TYPE, FLANGED ENDS

DESCRIPTION: Angled type cast steel, metal seated, quick closing globe valve. Release cylinder for pneumatic, hydraulic or mechanical remote control. Raised face flanged.

APPLICATION: Remote emergency shut off valve for fuels, oils and other combustible liquids. Engine room installation etc.

STANDARD & DESIGN:

Design Code: -
 Inspection Std.: -
 End Std.: EN 1092/B (DIN 2501)
 Face to Face Std.: EN 558 Series 8 (DIN 3202 F32)
 Flanges drilled: PN16 (DN15-DN150)
 PN10 (DN200)
 Pressure rating: PN16 (DN15-DN150)
 PN10 (DN200)
 Temperature range: -10°C to +150°C

VARIATIONS: Other dimensions and materials on request.
 Impuls unit for remote control.

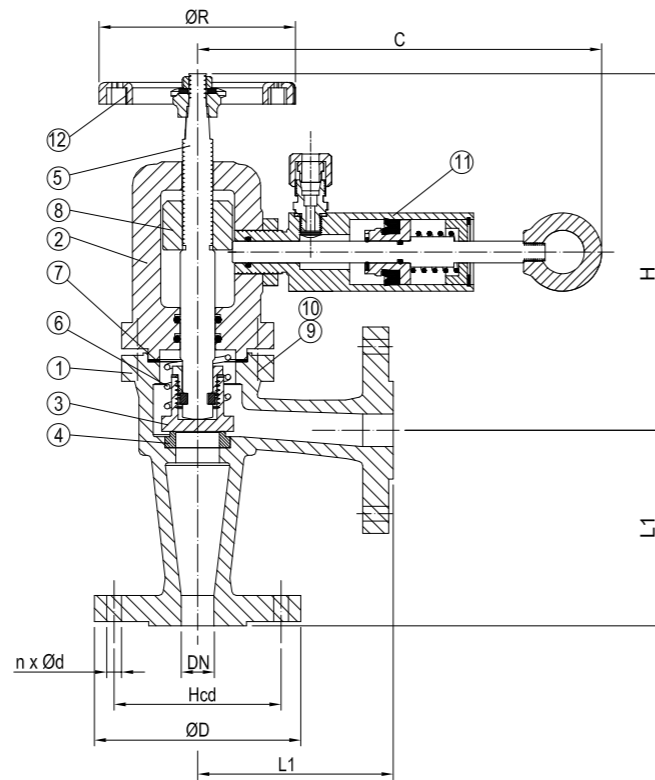
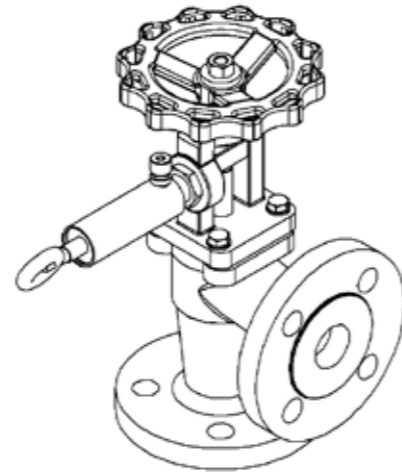

Pressure & Temperature ranges:

Bore	Working Pressure(Bar)	
	150°C	
DN15-DN150	16	
DN200	10	

No	Part	Material	Code
1	Body	Cast Steel	GP240GH(GSC25)
2	Bonnet	Cast Steel	GP240GH(GSC25)
3	Disc	Stainless Steel	X20Cr13(1.4021)
4	Seat	Stainless Steel	AISI304(1.4301)
5	Stem	Stainless Steel	X20Cr13(1.4021)
6	Spring	Spring Steel	1.4310
7	Bonnet Gasket	Graphite	-
8	Retainer Block	Brass	CuZn39Pb3
9	Stud Bolt	Steel	-
10	Nut	Steel	-
11	Cylinder	Brass	CuZn39Pb3
12	Hand wheel	Cast Iron	EN-GJL250

DN	n x ød	Hcd	øD	L1	H	øR	C	Kg
15	4x14	65	95	90	170	120	190	3.8
20	4x14	75	105	95	170	120	190	4.0
25	4x14	85	115	100	180	140	190	5.0
32	4x18	100	140	105	180	140	190	7.0
40	4x18	110	150	115	200	160	195	10.0
50	4x18	125	165	125	200	160	195	12.0
65	4x18	145	185	145	225	180	195	17.0
80	8x18	160	200	155	245	200	195	23.0
100	8x18	180	220	175	275	225	195	33.0
125	8x18	210	250	200	275	250	195	50.0
150	8x22	240	285	225	315	300	195	70.0
200	8x22	295	340	275	360	400	195	110.0



STEAM TRAPS & PRESSURE REDUCING VALVES

Valves and Steam Traps suitable for steam systems. In this valve range we supply specific pressure reducing valves and Steam traps. We also supply other applicable safety valves, stop valves, regulating valves, check valves and strainers. Please see the chapter of each respective category.



STEAM TRAP

THREADED/FLANGED ENDS

841063/841163
PN40

DESCRIPTION: Thermostatic steam trap, regulated by a membrane regulator. Automatically vent non-condensables. No live steam loss. Insensitive to water hammer and back pressure. Large integral Y-strainer. Easy installation, in-line inspection and maintenance.

APPLICATION: For light and medium condensate capacities. Unit heaters, small heat exchangers, heating coils etc.

STANDARD & DESIGN:

Design Code: -
 Inspection Std.: -
 End Std.: BSP, DIN ISO 228 (841063)
 DIN 2501 (841163)

Face to Face Std.: -
 Flanges Drilled: PN40(DN15-DN25)
 Pressure rating: PN40(DN15-DN25)
 Max. operating temperature: 428°F (220°C)
 Max. differential pressure: 320psi (22 bar)

VARIATIONS: Of special membrane Regulators "H" = 5°C (9°F) subcooling
 "L" = 30°C (54°F) subcooling

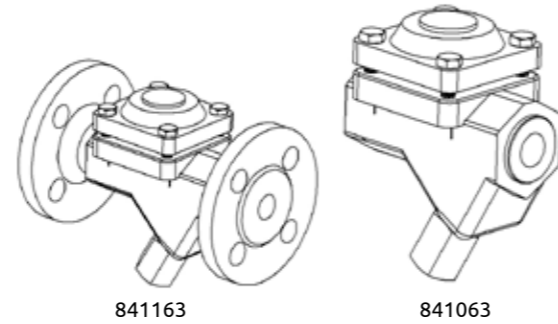
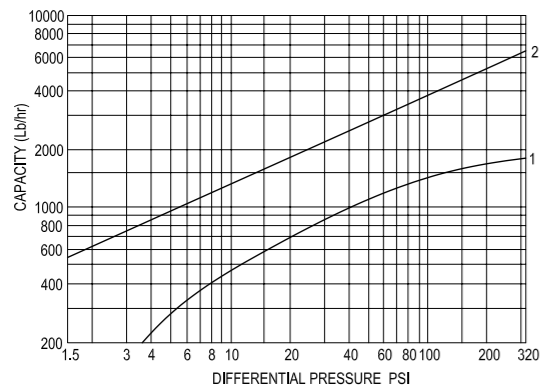

841163

841063

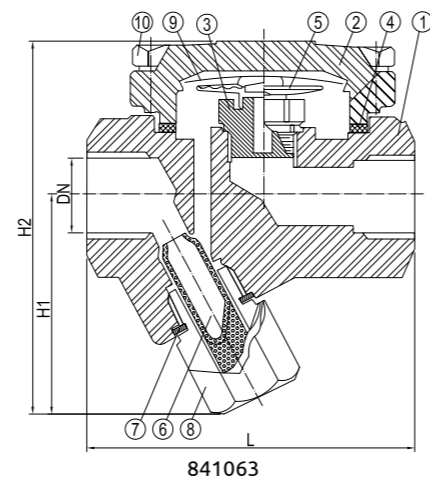

841063

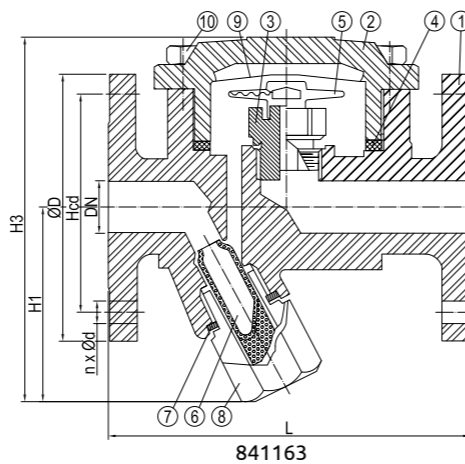

841163

No	Part	Material	Code
1	Body	Carbon Steel	A105
2	Cover	Carbon Steel	A105
3	Nozzle Seat	Stainless Steel	-
4	Cover Gasket	Grafoil	-
5	Membrane Regulator	Stainless Steel & Hastelloy	-
6	Strainer	Stainless Steel	-
7	Nozzle & Strainer Cap Washer	Stainless Steel	-
8	Strainer Cap Screw	C-Steel	-
9	Retainer	Stainless Steel	-
10	Bolts	Steel	ASTM 193-B7

841063							
DN	Inch	L	H1	H2			
15	1/2	95	70	120			
20	3/4	95	70	120			
25	1	95	70	120			

841163							
DN	n x ød	Hcd	øD	L	H1	H3	
15	4x14	65	95	150	70	125	
20	4x14	75	105	150	70	125	
25	4x14	85	115	160	70	125	



PRESSURE REDUCING VALVE

FLANGED ENDS

920301

DESCRIPTION: Straight type nodular cast iron body pilot operated steam pressure reducing valve. Primary pressure 1-3 barg. Flat face flanged.

APPLICATION: Process steam systems
 For reduction and accurate control of steam pressure.

STANDARD & DESIGN:

Design Code: -
 Inspection Std.: -
 End Std.: DIN 2501
 Face to Face Std.: -
 Flanges drilled: PN16(DN20-DN50)
 Max. operating pressure: 3 barg
 Max. operating temperature: 220°C
 Primary pressure range: 1-3 barg
 Adjustable pressure range: 0.1-0.5 barg
 Minimum adjustable flow rate: 5% of rated flow rate

VARIATIONS: Other material or End Std. on request.

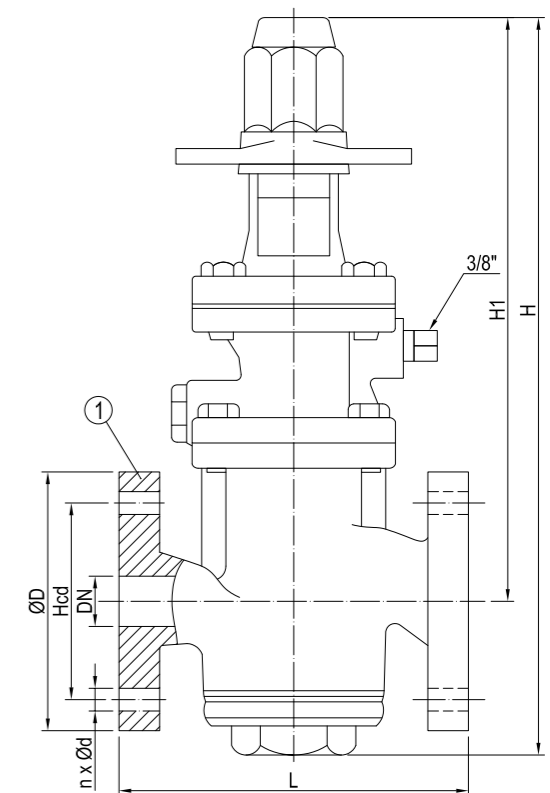
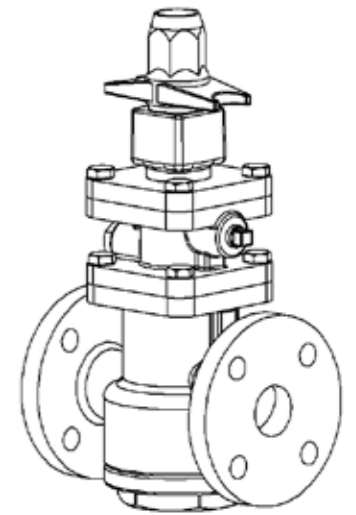

No	Part	Material	Code
1	Body	Ductile Cast Iron	GGG-40.3
2	Major Internal Parts	Stainless Steel	-

DN	n x ød	Hcd	øD	L	H	H1	Kg
20	4x14	75	105	150	357	285	11
25	4x14	85	115	160	357	282	13
32	4x18	100	140	180	385	302	19
40	4x18	110	150	200	385	302	20
50	4x18	125	165	230	412	315	27



PRESSURE REDUCING VALVE

921602

FLANGED ENDS

DESCRIPTION: Straight type nodular cast iron body pilot operated steam pressure reducing valve. Primary pressure 2-16 barg. Flat face flanged.

APPLICATION: Process steam systems
For reduction and accurate control of steam pressure.

STANDARD & DESIGN:

Design Code: -
 Inspection Std.: -
 End Std.: DIN 2501
 Face to Face Std.: -
 Flanges drilled: PN16(DN15-DN150)
 Max. operating pressure: 16 barg
 Max. operating temperature: 220°C
 Primary pressure range: 2-16 barg
 Adjustable pressure range: Within 10-84% of primary pressure but with a minimum pressure of 0.3 barg.
 Differential pressure between 0.7-8.5 bar
 Minimum adjustable flow rate: 5% of rated flow rate (DN15-DN50) 10% of rated flow rate (DN65-DN150)

VARIATIONS: Other material or End Std. on request.

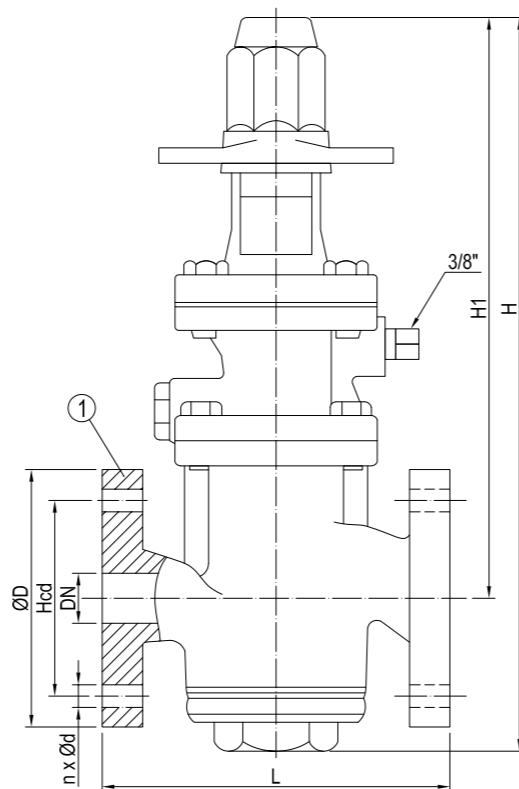
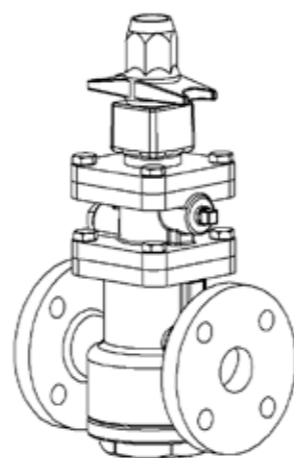

No	Part	Material	Code
1	Body	Ductile Cast Iron	GGG-40.3
2	Major Internal Parts	Stainless Steel	-

DN	n x ød	Hcd	øD	L	H	H1	Kg
15	4x14	65	95	130	357	285	10
20	4x14	75	105	150	357	285	11
25	4x14	85	115	160	357	282	13
32	4x18	100	140	180	385	302	19
40	4x18	110	150	200	385	302	20
50	4x18	125	165	230	412	315	27
65	4x18	145	185	290	554	411	57
80	8x18	160	200	310	554	411	58
100	8x18	180	220	350	633	448	87
150	8x22	240	285	480	810	530	204



GLOBE VALVES & FLAP VALVES TYPE WT-MESON

The hand operated and pneumatically operated valves in this range is former Wärtsila/TEBUL construction that now is manufactured by MESON.
We supply spare parts and new complete valves for newbuildings and to replace existing valves.

Figure 1

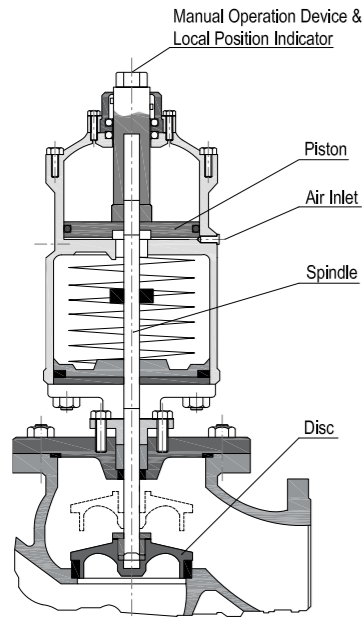

PNEUMATICALLY-OPERATED STRAIGHT AND ANGLE VALVES (TYPE PV)

Figure 1 depicts the construction of a straight valve with the disc fixed to the spindle.

The construction of the actuator, disc and seat are identical in the single valve. The valves are two position valves (open/closed).

The disc is shaped to ensure gentle opening and closing of the valve, and thus gentle acceleration and deceleration of the fluid flow.

The valve can be fitted in any position.

Fluid can flow from the lower or upper side of the disc, if the actuator is able to:

- Open the valve, using 6-7 bar pressure, against the highest pressure that can occur on the upper side of the valve disc.

- Keep the valve closed, using the spring force, against the highest pressure that can occur on the lower side of the valve disc.

Figure 2

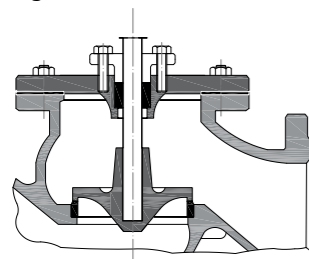
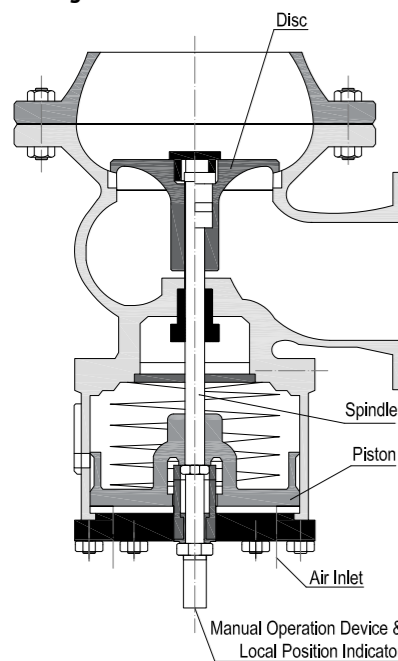

Figure 3



PNEUMATICALLY-OPERATED ANGLE VALVES FOR BRANCH PIPING, INCLUDING AN ADAPTER FOR THE MAIN PIPE (TYPE R).

Figure 3 shows the construction of the valve and actuator.

The valve is a two-position valve (open/closed), which can be fitted in any position. Fluid can flow from the lower or upper side of the disc, if the actuator is able to:

- Open the valve, using 6-7 bar pressure, against the highest pressure that can occur on the upper side of the valve disc.

- Keep the valve closed, using the spring force, against the highest pressure that can occur on the lower side of the valve disc.

Figure 2 shows the construction of the disc, including the check valve function. (Construction of all other elements as in Figure 1).

A valve with a check valve function must be fitted with the actuator upright. Free flow is possible only from the lower side of the disc.

If back flow tends to take place after the valve is opened, the disc, which moves longitudinally on the spindle, will close in the flow path.

Actuator size	Air consumption per stroke(L)
1	2.5
3	8.5
5	27.5
6	23

The air consumption of the actuators at 6 bar pressure is given in the adjoining table in litres free air/stroke.

Actuators are equipped with a device for opening the valves manually.

The dimensions of the valve actuator assemblies, as well as the pressure available are listed in Table 1.

The valve is available with a check valve function. In this case, the valve must be fitted with the actuator facing downward. Free flow is only possible from the branch pipe to the main pipe.

The actuator is equipped with a device for opening the valve manually.

The consumption of the actuators at 6 bar air pressure is expressed in litres free air/stroke, or 3.5 l for a size 3 actuator and 10 l for a size 5 actuator.

The dimensions of the valve/actuator/adapter assemblies are listed in Table 2.

Other types of adapters are also available.

Table 1 / Type PV

DN	Actuator size	øD	L	L1	Fixed disk type				Check valve function		
					H	H1	Pressure bar		H	H1	Pressure bar
							P ₁ ¹⁾	P ₂ ²⁾			
25	1	115	160	100	434	416	6.5	16	423	405	16.0
40	1	150	200	115	446	423	3.5	8.5	434	411	10.0
50	1	165	230	125	485	438	3.5	4.5	467	420	6.8
65	1	185	290	145	477	439	2.5	2.3	457	419	3.7
80	1	200	310	155	505	458	1.9	1.3	486	439	2.2
100	1	220	350	175	525	467	1.2	0.8	513	455	1.2
65	3	185	290	145	594	556	5.5	8.5	569	531	12
80	3	200	310	155	622	575	5.0	5.5	598	551	7.5
100	3	220	350	175	652	594	4.0	3.0	625	567	4.5
125	3	250	400	200	670	605	3.0	1.5	640	575	2.5
150	3	285	480	225	695	620	2.0	1.0	675	600	1.5
80	5	200	310	155	697	650	6.0	12.0	663	616	16.0
100	5	220	350	175	727	669	5.5	7.5	690	632	10.0
125	5	250	400	200	745	680	4.5	4.5	705	640	6.5
150	5	285	480	225	775	700	3.5	3.0	740	665	4.0
200	5	340	600	275	-	-	-	-	805	710	2.0
250	5	395	730	325	-	-	-	-	864	755	1.0
150	6	285	480	225	894	819	1.6	4.8	859	784	5.5
200	6	340	600	275	969	874	2.0 ³⁾	2.4	924	829	2.9
250	6	395	730	325	1013	904	1.1 ³⁾	1.8	983	874	2.0 ³⁾
300	6	445	850	375	-	-	-	-	1074	924	1.3 ³⁾

1) P₁ is the maximum pressure on the upper side of the disc, against which the actuators can open the valve at 6 bar air pressure. The pressure on the lower side of disc is assumed to be zero.

2) P₂ is the maximum pressure on the lower side of the disc, against which the springs in the actuator are capable of keeping the valve closed.

The pressure on the upper side of the disc is assumed to be zero.

3) At 7 bar air pressure

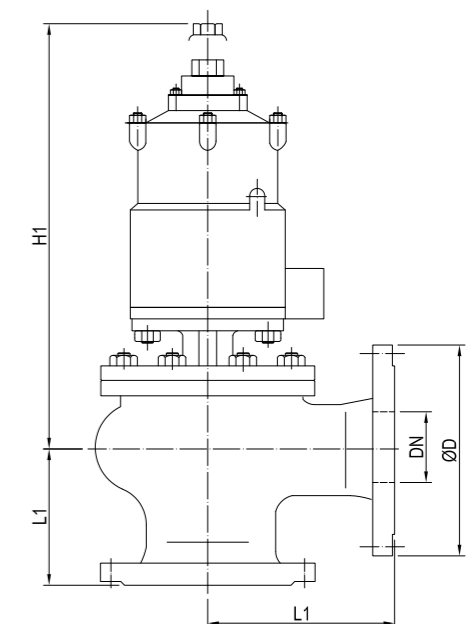
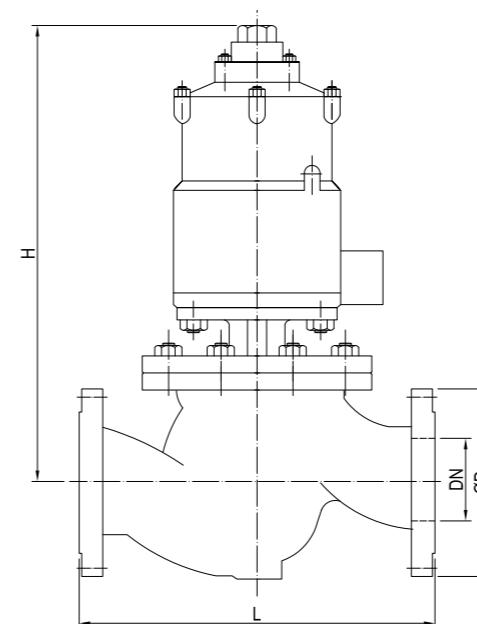



PNEUMATIC GLOBE VALVE

WT-MESON



PNEUMATIC GLOBE VALVE

WT-MESON

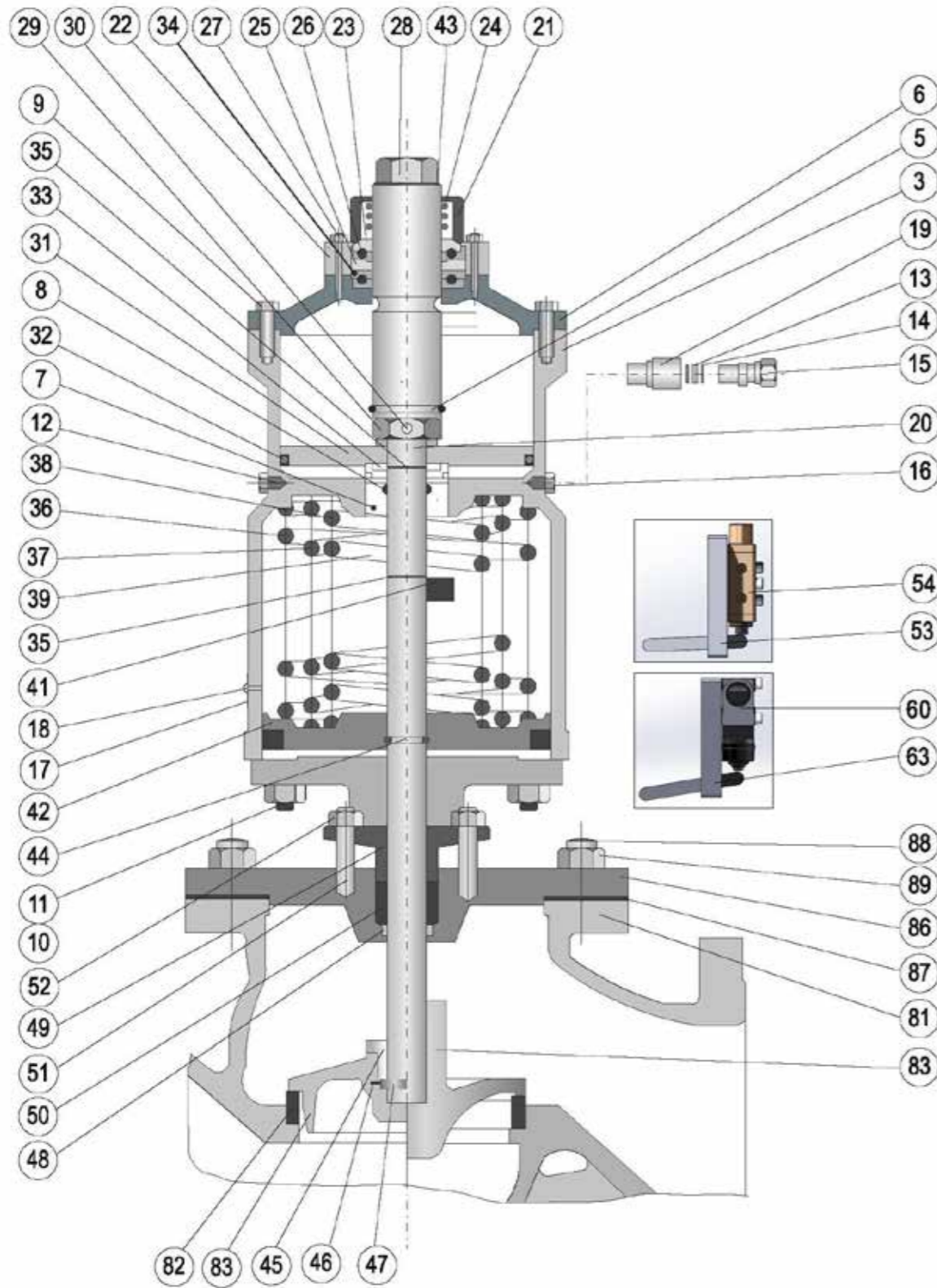

Ref No:	Part	Quant./Valve		Material
		Fixed cone	Non return cone	
3	Cylinder	1	1	Cast Iron
5	O-Shaped Snap Ring	1	1	Spring Bronze
6	Cylinder Cover	1	1	Cast Iron
7	Bushing	1	1	Brass
8	O-Ring	2	2	Synthetic Rubber
9	Bolt	4	4	Steel
10	Stud Bolt	4	4	Steel
11	Nut	4	4	Steel
12	Plug	1	1	Brass
13	Throttle Piece *	1	1	Brass
14	Filter *	2	2	Brass
15	Pipe Fitting *	1	1	Steel
16	Air Vent	1	1	-
17	Label	1	1	Al. Oxidized
18	Rivet	2	2	Brass
19	Pipe Fitting *	1	1	Brass
20	Spindle	1	1	Stainless Steel
21	Sliding Bushing	1	1	Steel
22	Stop Bushing	1	1	Steel
23	Stop Ring	1	1	Steel
24	Spring	1	1	Spring Steel
25	Ball Ring	1	1	Steel
26	Steel Ball	11/15/17	11/15/17	Steel
27	Slotted Screw	4	4	Steel
28	Operating Bushing	1	1	Steel
29	Nut	1	1	Steel
30	Locking Screw	1	1	Steel
31	Piston	1	1	Steel
32	O-Ring	1	1	Synthetic Rubber
33	Washer	1	1	Steel
34	Ball Bearing	1	1	Steel
35	Snap Ring	1	1/2	Steel
36	Comp. Spring	1	1	Spring Steel
37	Comp. Spring	1	1	Spring Steel
38	Comp. Spring	1	1	Spring Steel
39	Comp. Spring	1	1	Spring Steel
41	Stop Ring	-	1	Steel
42	Spring Disc	1	1	Steel
43	Snap Ring	1	1	Steel
44	O-Shaped Snap Ring	1	1/2	Spring Bronze
45	Lid Fixing Screw	1	-	Brass
46	Locking Washer	1	-	Brass
47	Split Ring	1	-	Stainless Steel
48	Bottom Ring	1	1	Brass

* Parts with Ref No: 13, 14 15 and 19 only delivered together as one kit.

Drawing No. - 1.810.0320(Act. 1-5)
1.810.0321(Act. 6)

Drawing No. - 1.810.0320(Act. 1-5)
1.810.0321(Act. 6)



PNEUMATIC GLOBE VALVE

WT-MESON

Ref No:	Part	Quant./Valve		Material
		Fixed cone	Non return cone	
49	Box Gland	1	1	Bronze
50	Packing	4	4	Grafoil Ribb. Pack
51	Stud Bolt	2	2	Stainless Steel
52	Nut	2	2	Brass
81	Valve Body	1	1	Cast Iron/ Steel/ Bronze
82	Seat	1	1	Bronze
83	Cone	1	1	Bronze
86	Body Cover	1	1	Cast Iron/ Steel/ Bronze
87	Gasket	4/8	4/8/10	Steel
89	Nut	4/8	4/8/10	Steel
53	Lever Mechanism	1 (Optional)		Aluminum
54	Pneumatic Position Indicator	1 (optional)		-
60	Lever Mechanism	1 (optional)		Aluminum
63	Electric Position Indicator	1 (optional)		-

Drawing No. - 1.810.0320(Act. 1-5)
1.810.0321(Act. 6)



FLAP VALVE

PNEUMATIC/HAND-OPERATED

WT-MESON

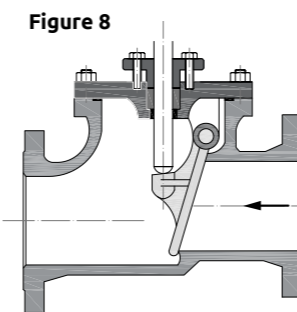
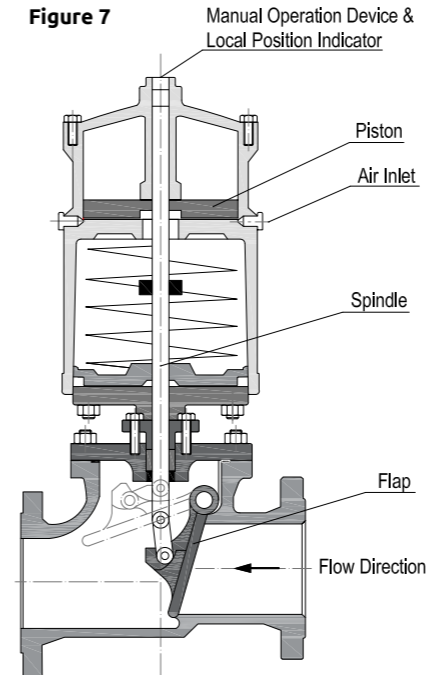

Table 5 / Type PVL

DN	Actuator size	øD	øD1	L ¹⁾	A	H ²⁾	H1 ³⁾
65	3	185	188	270	0	650	660
80	3	200	188	275	12	650	665
100	3	220	188	310	12	660	675
125	3	250	188	360	20	670	685
125	5	250	244	360	20	735	750
150	5	285	244	435	21	820	825

1)The dimension is non-standard

2) Fixed flap type 3) Check valve function

Table 6 / Type HVL

DN	øD	L ¹⁾	A	H	øR
65	185	270	0	406	140
80	200	275	12	433	180
100	220	310	12	386	180
125	250	360	20	462	200
150	285	435	21	753	200

1)The dimension is non-standard

In this valve type, the closing part is swing-type flap.

The valve is intended for piping system where the fluid may contain non-fluid material, as in sewage piping.

The valve is available in both pneumatic and hand-operated modes.

PNEUMATICALLY-OPERATED VALVES (TYPE PVL)

Figure 7 shows the construction of the valve and actuator. In this valve, the flap is fixed to the spindle. It can be fixed in any position.

The valve is a two position valve (open/closed).

Flow direction should preferably be as pictured in the figure.

Figure 8 depicts the construction of the valve with a check valve function. (Construction of all other elements as in Figure 7).

The valve with check valve function must be fitted with the actuator upright. Free flow is possible only from the lower

side of the disk. If back flow tends to take place after the valve is opened, the disk, which moves longitudinally on the spindle, will close in flow path.

The air consumption of the actuators at 6 bar air pressure is expressed in litres free air/stroke, or 8.5 l for a size 3 actuator and 17.5 l for a size 5 actuator.

The dimensions of the valve/actuator assemblies and the pressures available are given in Table 5.

HAND-OPERATED VALVES (TYPE HVL)

The construction of the flap and all related parts is the same as in the pneumatically-operated valve, see Figures 7 and 8.

Valves with and without check valve function are available.

A valve with check valve function must be fitted with the spindle upright.

Valve dimensions are given in Table 6.

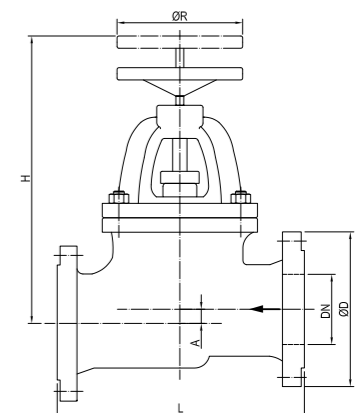
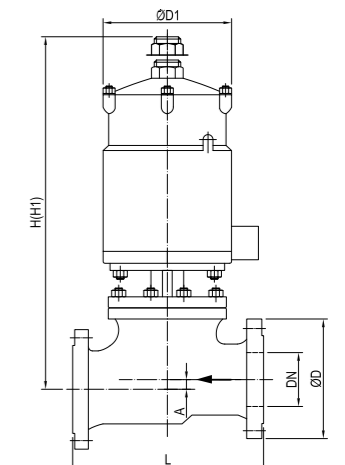



FLAP VALVE

PNEUMATIC/HAND-OPERATED

WT-MESON



ORDER INFORMATION

WT-MESON

VARIANTS:

The Flap valve can also be operated with a Pneumatic actuator, Type PVL.
Without closing device, Type VL.

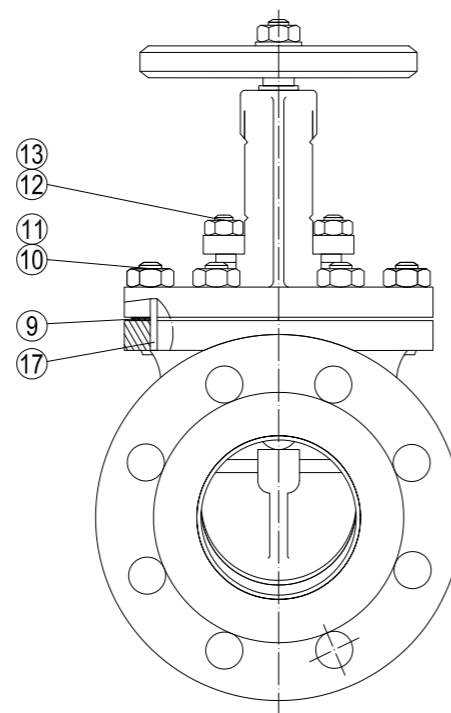
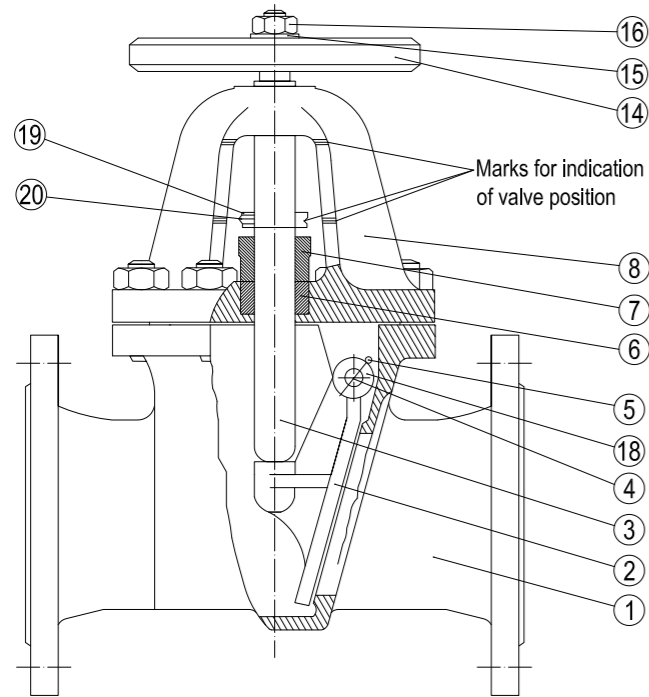

Ref.No	Part	Qty/Valve	Material
1	Valve body	1	Bronze Rg10
2	Disc	1	Bronze Rg10
3	Spindle	1	Bronze Rg10
4	Axle	1	Stainless steel
5	Split pin	2	Stainless steel
6	Packing	4	Grafoil ring
7	Box gland	1	Bronze Rg10
8	Body cover	1	Bronze Rg10
9	Gasket	1	Klinger seal
10	Nut	8	Steel
11	Stud bolt	8	Steel
12	Nut	2	Steel
13	Stud Bolt	2	Stainless steel
14	Handwheel	1	Cast iron
15	Washer	1	Steel
16	Nut	1	Steel
17	Pin	2	Steel
18	Washer	2	Stainless steel
19	Stop ring	1	Steel
20	Locking screw	1	Steel

Drawing No. - 1.810.0606
Type HVL-T

TYPE MARKING OF VALVES WITH ACTUATORS

(Stamped to the type plate of the valve)

TYPE EXAMPLE: HDV 80- H 1 T A

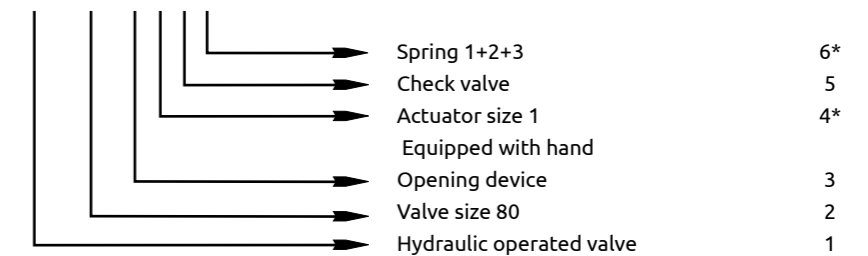

- HDV= Hydraulic operated valve
HDVL= Hydraulic operated flap valve
PV= Pneumatic valve
HV= Hand valve
PVL= Pneumatic flap valve
HVL= Hand operated flap valve
- Valve sizes DN25, DN40, DN65, DN80, DN100, DN125, DN150, DN200, DN250 and DN300
- H= Equipped with hand opening device
- Actuator sizes 1, 3, 5 and 6
- T= Check valve type
K= Angle
S= special
R= Hanging
Letter combinations are possible
- Spring code:
Each actuator size has its own spring set including 3-5 different springs.
The codes of springs are: 1, 2, 3, 4 or 5
The codes of springs combinations are:

EXAMPLE:

PV50-H1AS

PV = Pneumatic valve
50 = Valve size
H = Equipped with hand opening device
1 = Actuator size
A = Spring code
S = Special

A= Spring	1+2+3	AL=	1+2+3+4
B=	1+2	BL=	1+2+3
C=	1+2	CL=	1+3+4
D=	2+3	DL=	2+3+4
E=	1	EL=	1+4
F=	2	FL=	2+4
H=	3	HL=	3+4
L=	4	AV=	1+2+3+5
V=	5	AVL=	1+2+3+4+5

The size of spring set is determined by the valve size, where the actuator is assembled, as well as by the requested spring force in each case.
These codes represent the capacity of the actuator.



VARIOUS OTHER EQUIPMENT

In this section we cover several additional valve types and related equipment. For example expansion joints, ejectors, vent check valves, level gauges and much more. Even if the valve or equipment that you are looking for is not in our catalogue it doesn't mean that we can't deliver it. Please feel free to contact us with any inquiry.



EXPANSION JOINT

FLANGED ENDS

130062/61
PN16/PN10

DESCRIPTION: Expansion joint with vulcanized bellow connection to zinc plated raised face steel flange. Allows for flexibility in radial and axial direction.

APPLICATION: Compensation for thermal expansion/contraction and misalignment etc. Bellow material will set and limit media and thermal range.

STANDARD & DESIGN:

Design Code: -
 Inspection Std.: -
 End Std.: -
 Face to Face Std.: -
 Flanges Drilled: PN16(DN32-DN150)
 PN10(DN200-DN300)
 Pressure rating: PN16(DN32-DN150)
 PN10(DN200-DN300)

VARIATIONS: Bellow material: EPDM, NBR, Hypalon, SBR

Teflon lining
 Vacuum rings
 Flame guard
 Stainless steel flanges
 Sizes DN200-DN300 available PN16 on request

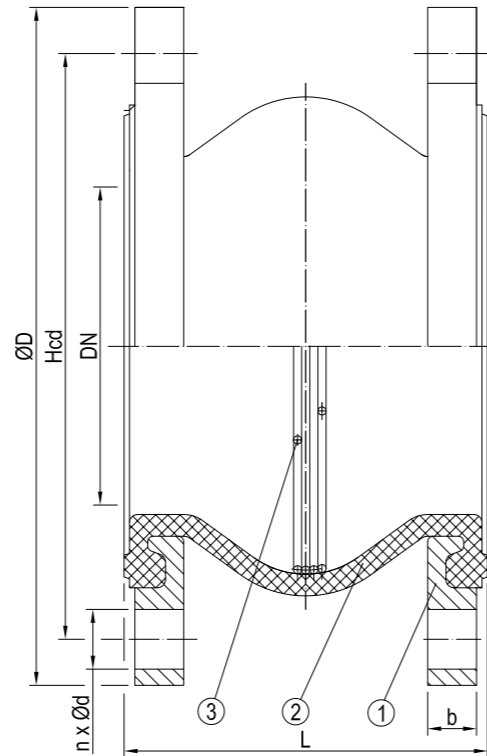
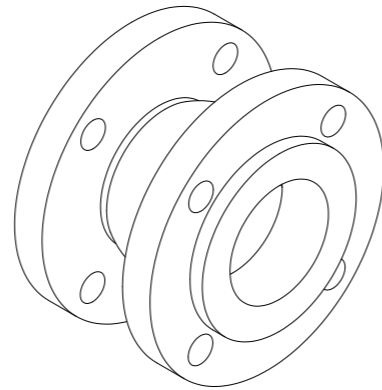

No	Part	Material	Code
1	Flange	Zinc Plated Steel	-
2	Sphere	NBR/EPDM/Viton	-
3	Vacuum Ring	Stainless Steel	SS316

DN	n x ød	Hcd	øD	L	b	Kg
32	4x18	100	140	130	16	3.2
40	4x18	110	150	130	16	3.8
50	4x18	125	165	130	16	4.5
65	4x18	145	185	130	16	5.5
80	8x18	160	200	130	18	6.7
100	8x18	180	220	130	18	7.3
125	8x18	210	250	130	20	9.8
150	8x22	240	285	130	22	13.3
200	8x22	295	340	130	22	18.1
250	12x22	350	395	130	24	25.6
300	12x22	400	445	130	26	31.3



EJECTOR

THREADED ENDS

319122

DESCRIPTION: Industrial ejector, female and male threaded. Rg5 body ejector with BSP thread connections.

APPLICATION: For suction and discharge of particles, liquids, slurries etc. not suitable for pumping.

STANDARD & DESIGN:

Design Code: -
 Inspection Std.: -
 End Std.: BSP
 Face to Face Std.: -
 Pressure range: 2 bar - 12.5 bar(DN15-DN25)

VARIATIONS: Flanged execution available up to DN200.

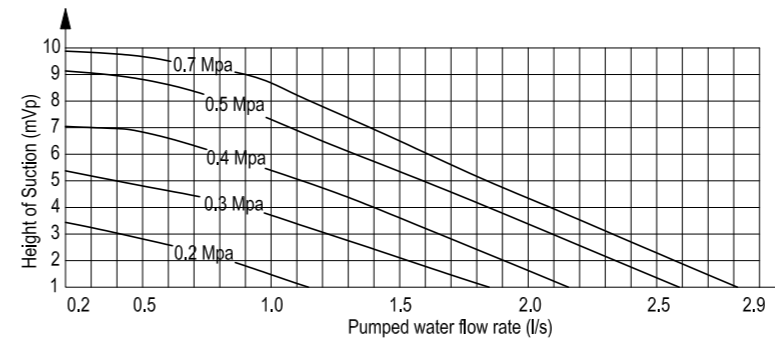
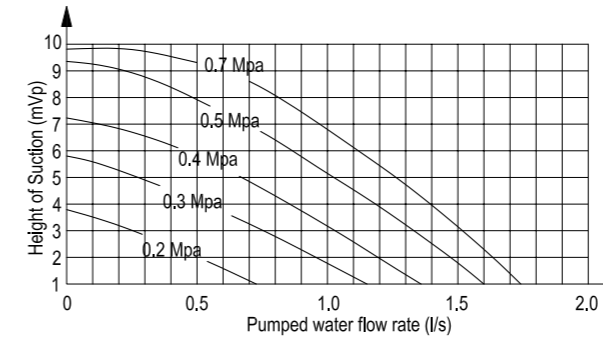
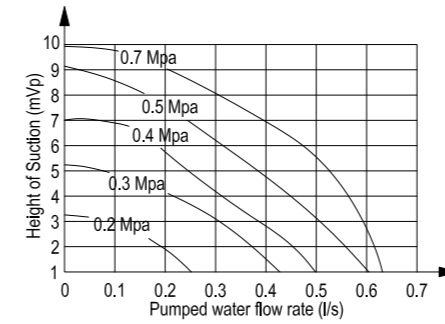
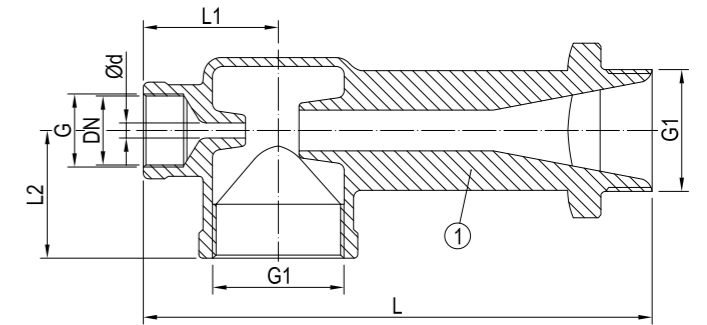
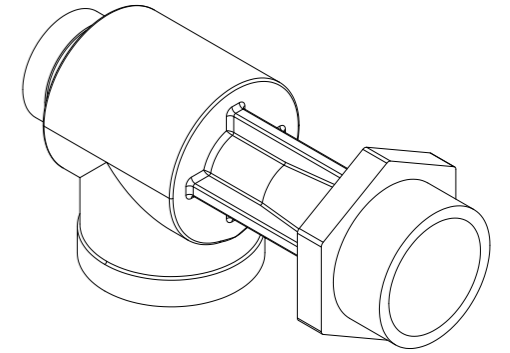

DN15

Vol. Operation Water	
Mpa	l/s
0.2	0.177
0.3	0.205
0.4	0.227
0.5	0.249
0.7	0.287

DN20

Vol. Operation Water	
Mpa	l/s
0.2	0.398
0.3	0.461
0.4	0.511
0.5	0.560
0.7	0.646

DN25

Vol. Operation Water	
Mpa	l/s
0.2	0.632
0.3	0.722
0.4	0.799
0.5	0.876
0.7	1.010

No	Part	Material	Code
1	Body	Bronze	CC491K

DN	G(Inch)	G1(Inch)	L	L1	L2	ød	Kg
15	1/2	1	144	40	34	4	0.7
20	3/4	1 1/2	190	50	48	6	1.4
25	1	2	203	58	59	7.5	2.5



AIR VENT CHECK VALVE

FLANGED ENDS

474961
PN10

DESCRIPTION: Hot dip galvanized body vent check valve.
Flat face flanged vertical connection.

APPLICATION: Prevention of sea water backflow in tank
ventilation pipe.

STANDARD & DESIGN:

Design Code: -
Inspection Std.: -
End Std.: -
Face to Face Std.: -
Flanges Drilled: PN10(DN40-DN400)
Pressure rating: PN10(DN40-DN400)

VARIATIONS: Epoxy coated or AISI 316L executions available
AISI 316 flame screen

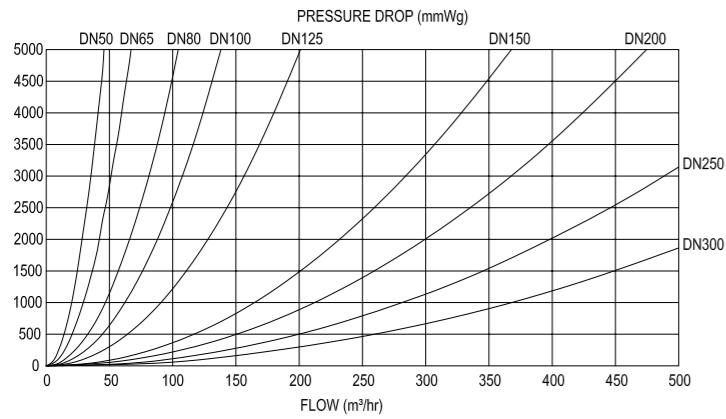

No	Part	Material	Code
1	Body	Hot dip galvanized steel	-
2	Cover	Hot dip galvanized steel	-
3	Screen	Stainless Steel	AISI 316L
4	Screen Clip	Stainless Steel	AISI 316L
5	Flange	Hot dip galvanized steel	-

DN	n x ød	Hcd	øD	L	H	H1	B	Kg
40	4x18	110	150	223	263	222	213	13
50	4x18	125	165	223	263	222	213	14
65	4x18	145	185	223	263	222	213	15
80	8x18	160	200	257	310	255	270	20
100	8x18	180	220	257	310	255	270	21
125	8x18	210	250	304	335	280	302	28
150	8x22	240	285	366	448	356	385	41
175	8x22	270	315	411	477	392	430	53
200	8x22	295	340	461	517	425	470	63
250	12x22	350	395	536	660	530	590	97
300	12x22	400	445	681	731	585	685	121
350	16x22	460	505	766	887	700	885	175
400	16x26	515	565	766	887	700	885	205

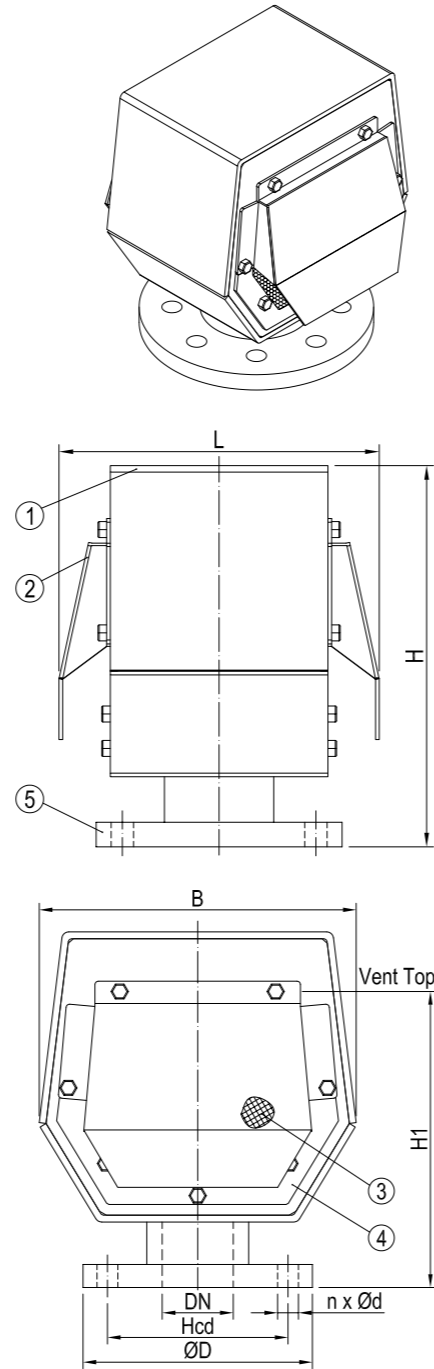

BLIND FLANGE VALVE

FLANGED ENDS

475062
PN16

DESCRIPTION: Cast steel body blind flange valve with AISI 316
equivalent disc and PTFE seal. Flat faced flanged.

APPLICATION: Temporary failsafe connection or separation of
pipeline/pipe system.

STANDARD & DESIGN:

Design Code: -
Inspection Std.: EN 12266-1
End Std.: -
Face to Face Std.: -
Flanges Drilled: PN16(DN40-DN300)
Pressure rating: PN16(DN40-DN300)
Temperature Range: -50°C to 200°C

VARIATIONS: Pressure rating and flange drilling
PN10/25/40 available for all sizes.

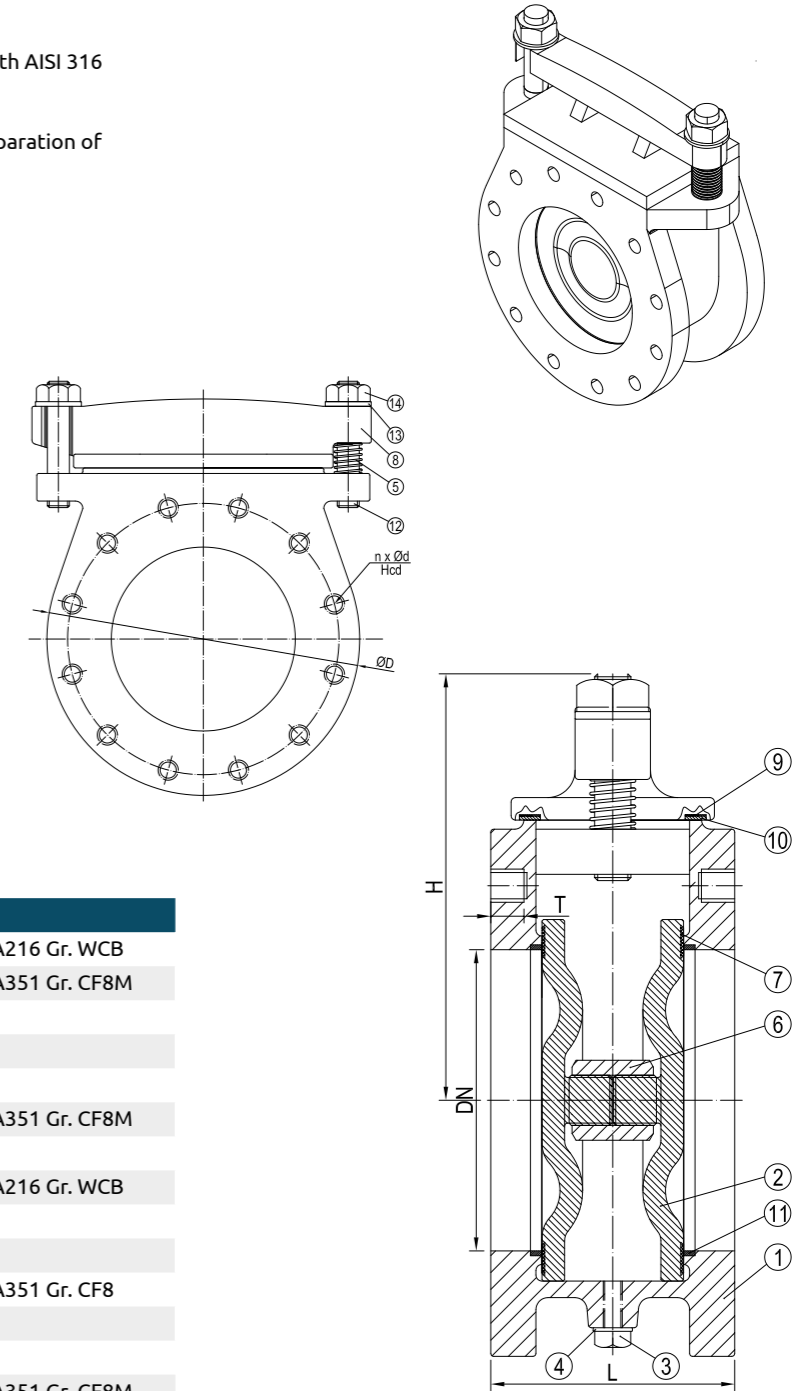

No	Part	Material	Code
1	Body	Cast Steel	ASTM A216 Gr. WCB
2	Disc	Stainless Steel	ASTM A351 Gr. CF8M
3	Drain Plug	Stainless Steel	SS316
4	Drain Plug Seal	PTFE	-
5	Spring	Stainless Steel	-
6	Tightening Nut	Stainless Steel	ASTM A351 Gr. CF8M
7	Disc Seal	PTFE	-
8	Top Cover	Cast Steel	ASTM A216 Gr. WCB
9	Top Seal	KEMFLOM	-
10	Top Seal	PTFE	-
11	Metal Ring	Stainless Steel	ASTM A351 Gr. CF8
12	Body Bolt	Stainless Steel	SS 316
13	Bolt Washer	Stainless Steel	SS 316
14	Bolt Nut	Stainless Steel	ASTM A351 Gr. CF8M

DN	n x ød	Hcd	øD	L	H	T	Kg
40	4xM16	110	150	154	180.5	17	-
50	4xM16	125	165	154	180.5	17	20.1
65	4xM16	145	185	154	191	18	24.4
80	8xM16	160	200	154	200	17	-
100	8xM16	180	220	162	233	19	36.3
125	8xM16	210	250	162	240	19	38.0
150	8xM20	240	285	162	258.5	19	44.7
200	12xM20	295	340	162	293	19	67.0
250	12xM24	355	405	200	320	25	104.0
300	12xM24	410	460	200	334	25	-



BLIND FLANGE VALVE

475092
PN16

FLANGED ENDS

DESCRIPTION: AISI 316 equivalent body blind flange valve with AISI 316 equivalent disc and PTFE seal. Flat faced flanged.

APPLICATION: Temporary failsafe connection or separation of pipeline/pipe system.

STANDARD & DESIGN:

- Design Code: -
- Inspection Std.: EN 12266-1
- End Std.: -
- Face to Face Std.: -
- Flanges Drilled: PN16(DN40-DN300)
- Pressure rating: PN16(DN40-DN300)
- Temperature Range: -50°C to 200°C

VARIATIONS: Pressure rating and flange drilling PN10/25/40 available for all sizes.

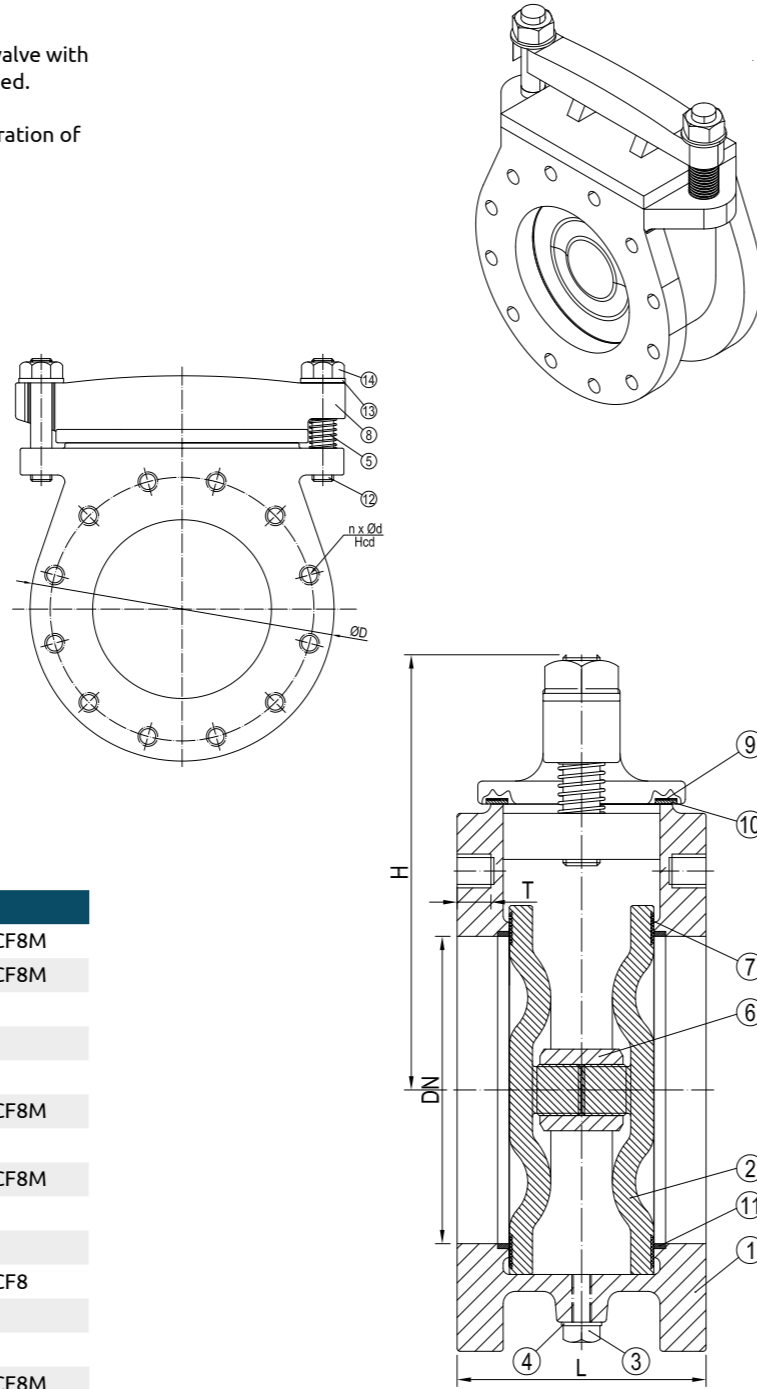

No	Part	Material	Code
1	Body	Stainless Steel	ASTM A351 Gr. CF8M
2	Disc	Stainless Steel	ASTM A351 Gr. CF8M
3	Drain Plug	Stainless Steel	SS316
4	Drain Plug Seal	PTFE	-
5	Spring	Stainless Steel	-
6	Tightening Nut	Stainless Steel	ASTM A351 Gr. CF8M
7	Disc Seal	PTFE	-
8	Top Cover	Stainless Steel	ASTM A351 Gr. CF8M
9	Top Seal	KEMFLOM	-
10	Top Seal	PTFE	-
11	Metal Ring	Stainless Steel	ASTM A351 Gr. CF8
12	Body Bolt	Stainless Steel	SS 316
13	Bolt Washer	Stainless Steel	SS 316
14	Bolt Nut	Stainless Steel	ASTM A351 Gr. CF8M

DN	n x ød	Hcd	øD	L	H	T	Kg
40	4xM16	110	150	154	180.5	17	-
50	4xM16	125	165	154	180.5	17	20.1
65	4xM16	145	185	154	191	18	24.4
80	8xM16	160	200	154	200	17	-
100	8xM16	180	220	162	233	19	36.3
125	8xM16	210	250	162	240	19	38.0
150	8xM20	240	285	162	258.5	19	44.7
200	12xM20	295	340	162	293	19	67.0
250	12xM24	355	405	200	320	25	104.0
300	12xM24	410	460	200	334	25	-



SIGHT GLASS

481091
PN10

THREADED ENDS

DESCRIPTION: Straight type AISI 316 equivalent body sight glass with internal flap. Female BSP threaded ends.

APPLICATION: For visual confirmation of pipe flow. Suitable for steam, water and acidic liquids.

STANDARD & DESIGN:

- Design Code: -
- Inspection Std.: -
- End Std.: BSP
- Face to Face Std.: -
- Pressure rating: PN10(DN15-DN50)

VARIATIONS: Other dimensions and materials on request.

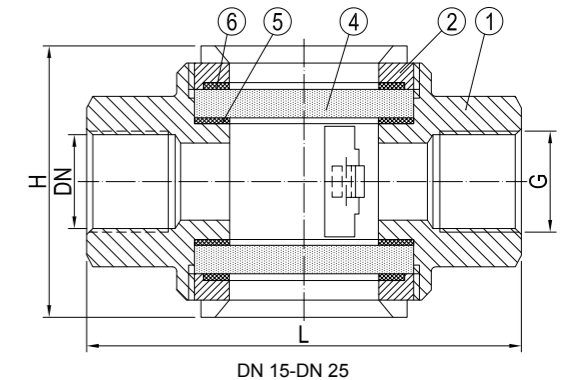
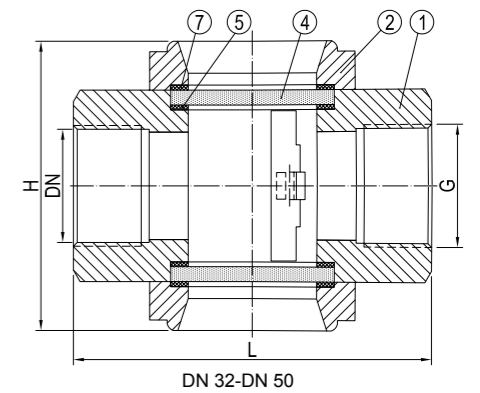
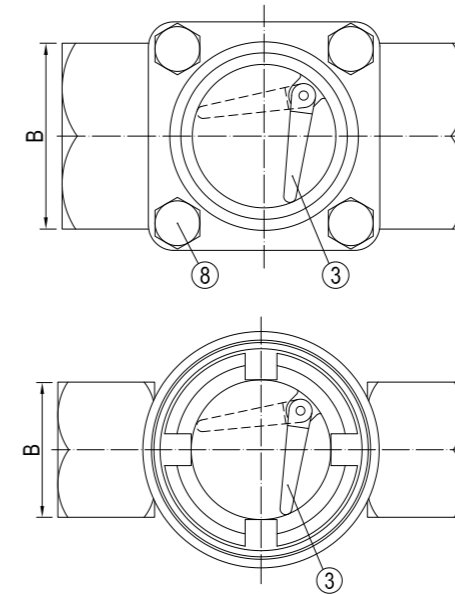
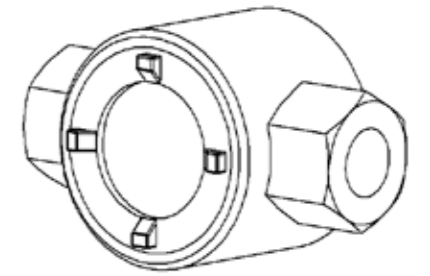

No	Part	Material	Code
1	Body	Stainless Steel	SS 316
2	Cap	Stainless Steel	SS 316
3	Disc	Stainless Steel	SS 316
4	Glass	-	-
5	Packing	PTFE	-
6	Packing	PTFE	-
7	Packing	Stainless Steel	SS 316
8	Bolt	PTFE	-

DN	G(Inch)	L	H	B	Kg
15	1/2	108	68	30	-
20	3/4	113	68	36	-
25	1	113	68	43	-
32	1 1/4	125	100	56	-
40	1 1/2	125	102	59	-
50	2	170	120	74	-



SIGHT GLASS

FLANGED ENDS

481162
PN16

DESCRIPTION: Straight type cast steel body sight glass with internal flap. Raised face flanged.

APPLICATION: For visual confirmation of pipe flow. Suitable for steam, water and liquids in general.

STANDARD & DESIGN:

Design Code: ASME B16.34
 Inspection Std.: API 598
 End Std.: PN16 DIN2633
 Face to Face Std.: DIN 3202-F1
 Flanges Drilled: PN16(DN15-DN150)
 Pressure rating: PN16(DN15-DN150)

VARIATIONS: Other dimensions and materials on request.

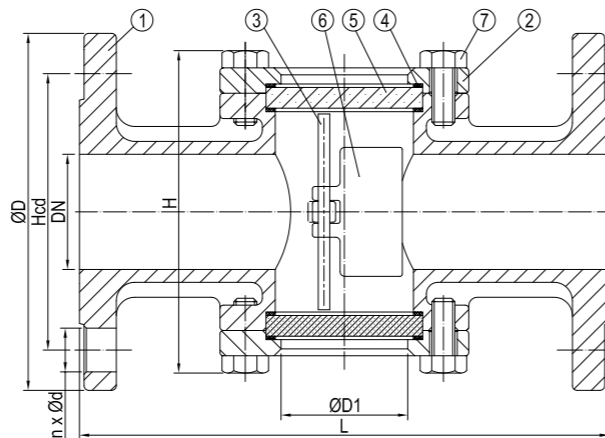
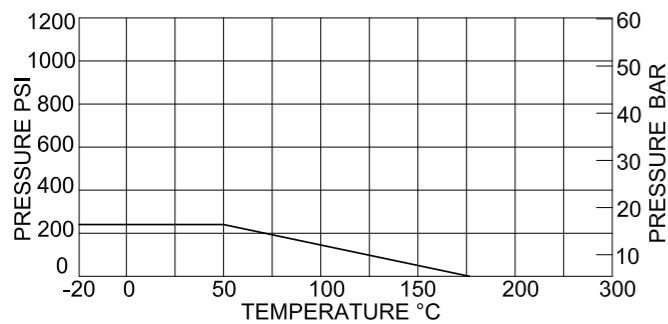
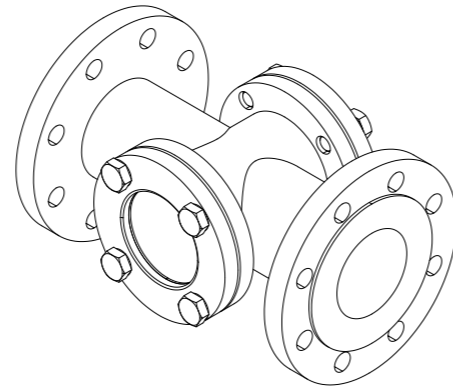

No	Part	Material	Code
1	Body	Cast Steel	1.0619
2	Cap	Cast Steel	1.0619
3	Stem	Stainless Steel	SUS 304
4	Gasket	PTFE	-
5	Glass Parcel	Glass	-
6	Indicator	Stainless Steel	1.4308
7	Bolt	Carbon Steel	-

DN	n x ød	Hcd	øD	øD1	L	H	Kg
15	4x14	65	95	35	130	115	3.1
20	4x14	75	105	35	150	115	3.7
25	4x14	85	115	35	160	115	4.0
32	4x18	100	140	55	180	143	6.6
40	4x18	110	150	55	200	143	7.7
50	4x18	125	165	55	230	143	9.0
65	4x18	145	185	85	290	185	14.2
80	8x18	160	200	85	310	196	17.1
100	8x18	180	220	110	350	228	23.1
150	8x22	240	285	160	480	310	47.4



SIGHT GLASS

FLANGED ENDS

481192
PN16

DESCRIPTION: Straight type AISI 316 equivalent body sight glass with internal flap. Raised face flanged.

APPLICATION: For visual confirmation of pipe flow. Suitable for steam, water and acidic liquids.

STANDARD & DESIGN:

Design Code: ASME B16.34
 Inspection Std.: API 598
 End Std.: PN16 DIN2633
 Face to Face Std.: DIN 3202-F1
 Flanges Drilled: PN16(DN15-DN150)
 Pressure rating: PN16(DN15-DN150)

VARIATIONS: Other dimensions and materials on request.

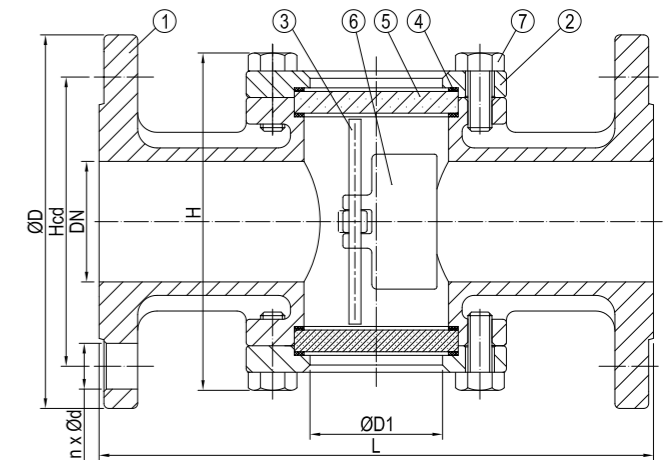
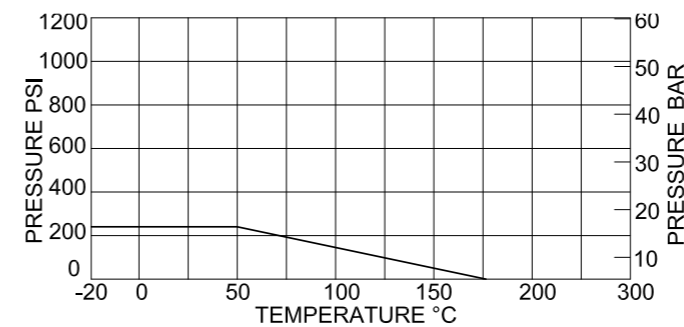
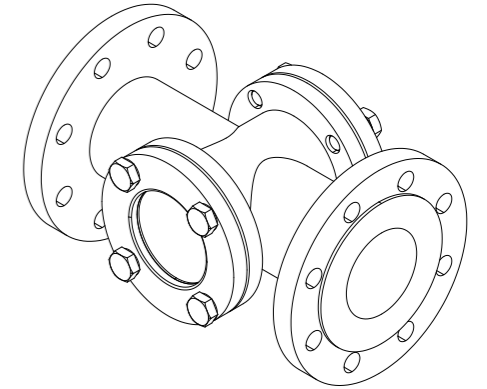

No	Part	Material	Code
1	Body	Stainless Steel	1.4408
2	Cap	Stainless Steel	1.4408
3	Stem	Stainless Steel	SUS 316
4	Gasket	PTFE	-
5	Glass Parcel	Glass	-
6	Indicator	Stainless Steel	1.4408
7	Bolt	Stainless Steel	SUS 304

DN	n x ød	Hcd	øD	øD1	L	H	Kg
15	4x14	65	95	35	130	115	3.1
20	4x14	75	105	35	150	115	3.7
25	4x14	85	115	35	160	115	4.0
32	4x18	100	140	55	180	143	6.6
40	4x18	110	150	55	200	143	7.7
50	4x18	125	165	55	230	143	9.0
65	4x18	145	185	85	290	185	14.6
80	8x18	160	200	85	310	196	17.1
100	8x18	180	220	110	350	228	23.1
150	8x22	240	285	160	480	310	47.4



SIGHT GLASS

FLANGED ENDS

481222
PN16

DESCRIPTION: Straight type Rg5 body sight glass with internal flap.
Flat face flanged.

APPLICATION: For visual confirmation of pipe flow.
Suitable for steam, sea water etc.

STANDARD & DESIGN:

Design Code: -
Inspection Std.: -
End Std.: -
Face to Face Std.: -
Flanges Drilled: PN16(DN15-DN100)
Pressure rating: PN16(DN15-DN100)

VARIATIONS: Other dimensions and materials on request.

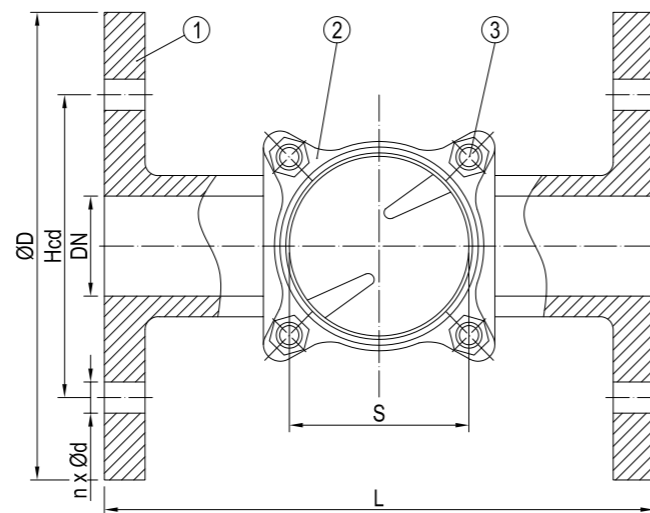
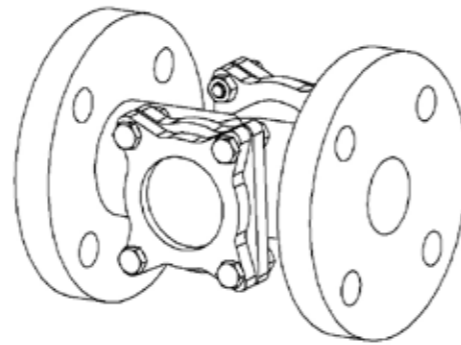

No	Part	Material	Code
1	Body	Bronze	-
2	Cap	Bronze	-
3	Bolt	Brass	-

DN	n x ød	Hcd	øD	L	S	Kg
15	4x14	65	95	110	44	2.5
20	4x14	75	105	120	44	2.8
25	4x14	85	115	135	44	3.0
32	4x18	100	140	150	50	4.8
40	4x18	110	150	180	50	5.7
50	4x18	125	165	200	63	9.0
65	4x18	145	185	240	82	12.3
80	8x18	160	200	260	94	16.0
100	8x18	180	220	300	110	12.3



VISUAL LEVEL CONTROLLER

THREADED ENDS

484421
PN10

DESCRIPTION: Rg5 body visual liquid level controller. GAZ male thread.

APPLICATION: For manual control of: Water, oil etc. levels in tanks and portable containers.

STANDARD & DESIGN:

Design Code: -
Inspection Std.: NF EN 12266-1/2 (bench test)
End Std.: Ø15 Conical GAZ Threads / Ø20 GAZ Threads
Face to Face Std.: -
Pressure rating: PN10(DN15-DN20)
Temperature range: Up to 80°C

VARIATIONS: With handwheel, push button or simple angle connector.
With intermediate connector for tubes longer than 1 meter.

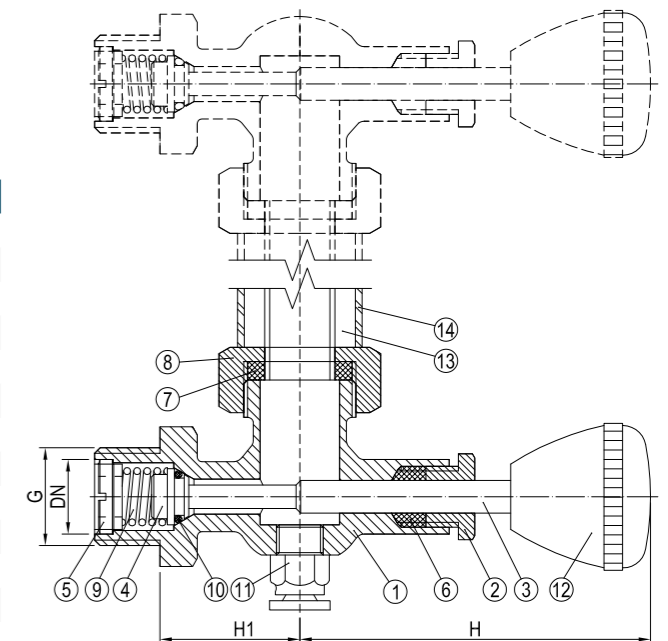
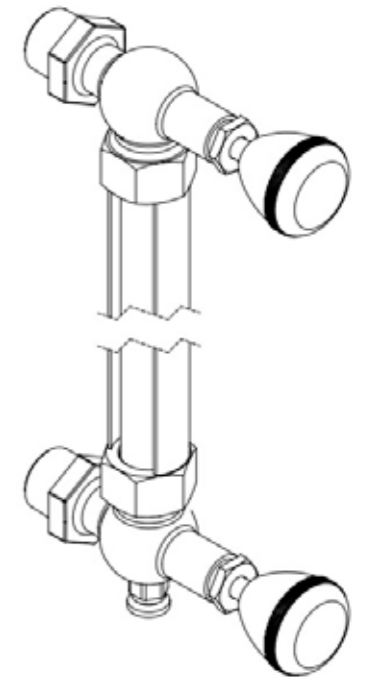
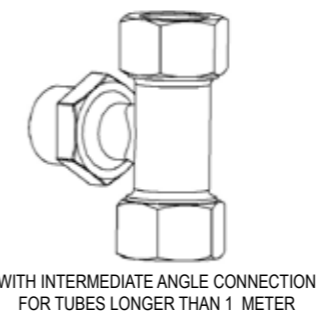
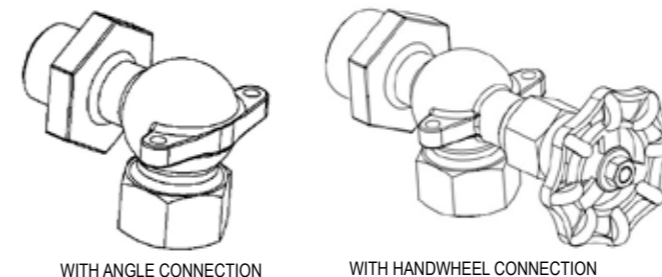

No	Part	Material	Code
1	Body	Bronze	CC491K
2	Packng Gland	Brass	-
3	Stem	Brass	-
4	Disc Holder	Brass	-
5	Stem Nut	Brass	-
6	Packing	Graphite+Fiber	-
7	Packing	FPM	-
8	Packing Nut	Brass	-
9	Spring	Stainless Steel	-
10	Gasket	FPM	-
11	Bleed Cock	Brass	-
12	Handle	Bakelite	-
13	Tube	Pyrex	-
14	Protection Cover	Brass	-

DN	G(inch)	H	H1	Kg
15	1/2	75	30	0.3
20	3/4	80	30	0.3



ANSI

VALVES ACCORDING TO AMERICAN
NATIONAL STANDARDS INSTITUTE (ANSI).

The valves in this section mainly follow the normative dimensions and pressure classes from the mentioned standardization organization. If not found here you may find the type of valve suitable for your need in other sections as well and we may also have the possibility to adopt a valve to fit your needs. Don't hesitate to contact us with any inquiry.



STOP VALVES

For shut off and regulating purposes.
Can be delivered with non-return disc or regulating disc.
Available with threaded, flanged or weld end connections.
Metal to metal sealing or soft sealing.
Available with different types of actuators.



GLOBE VALVE

STRAIGHT, FLANGED ENDS

467067
ANSI 150

DESCRIPTION: Straight type, forged steel body stop valve, Stellite trim with rising stem and bolted bonnet. Raised face flanged.

APPLICATION: Start/stop and throttling of: Air, water, oils, steam, oils and aggressive/abrasive media etc.

STANDARD & DESIGN:

Design Code: API 602 (DN15-DN40)
BS 1873 (DN50-DN150)
Inspection Std.: API 598
End Std.: ASME B16.5
Face to Face Std.: ASME B16.10
Flanges drilled: ANSI 150(DN15-DN150)
Pressure rating: ANSI 150(DN15-DN150)

VARIATIONS: Other dimensions and materials on request.

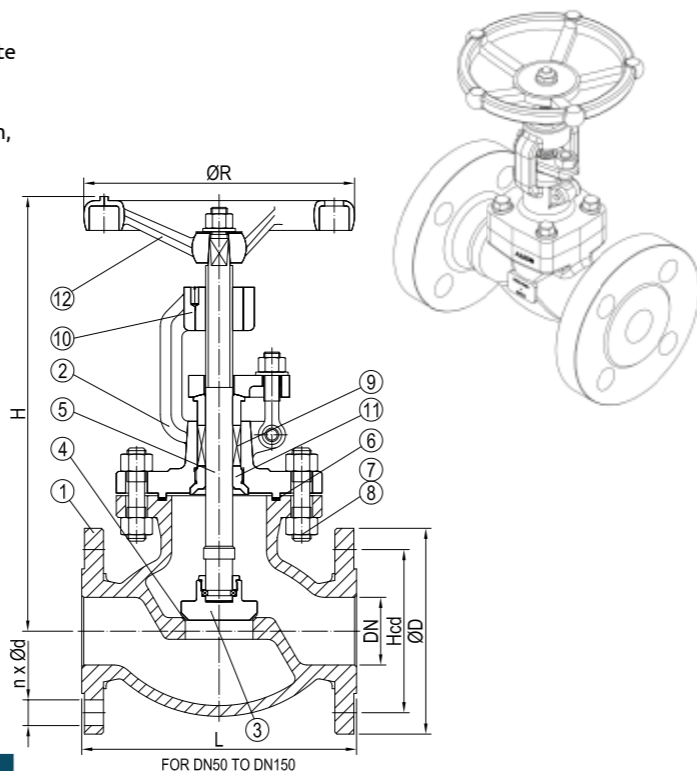

No	Part	Material	Code
1	Body (DN15-DN40)	Forged Steel	ASTM A105
		Cast Steel	ASTM A216-WCB
2	Bonnet (DN15-DN40)	Forged Steel	ASTM A105
		Cast Steel	ASTM A216-WCB
3	Disc (DN15-DN40)	Stainless Steel	ASTM A276-420
		Forged Steel	ASTM A105
4	Seat	Deposited Stellite	-
5	Stem (DN15-DN40)	Stainless Steel	ASTM A276-410
		Stainless Steel	ASTM A182-F6a
6	Bonnet Gasket	Graphite	-
7	Stud Bolt	Steel	ASTM A193 Gr.B7
8	Nut	Steel	ASTM A194 Gr.2H
9	Packing	Graphite	-
10	Stem Nut (DN15-DN40)	Carbon Steel	1045
		Al-Bronze alloy	-
11	Back Seat Bushing	Stainless Steel	ASTM A276-420
12	Handwheel (DN15-DN40)	Malleable Iron	ASTM A197
		Cast Iron	-

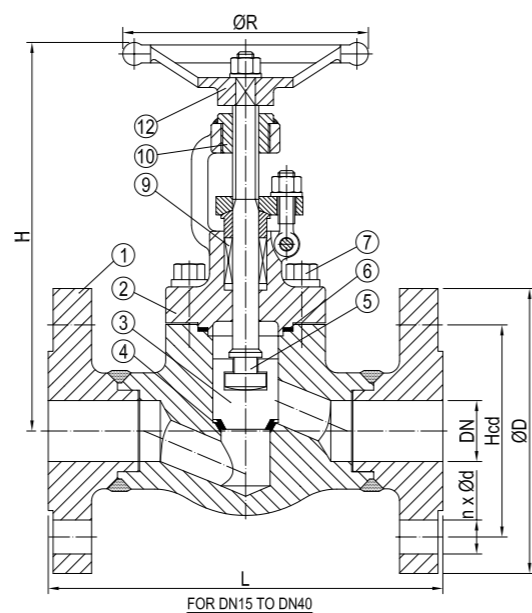

DN	n x ød	Hcd	øD	L	H	øR	Kg
15	4x16	60	90	108	155	100	3.5
20	4x16	69	100	117	155	100	3.8
25	4x16	80	110	127	176	125	5.7
32	4x16	89	115	140	200	160	8.5
40	4x16	98	125	165	220	160	10.7
50	4x19	121	150	203	370	200	18.0
65	4x19	140	180	216	420	240	30.0
80	4x19	152	190	241	460	240	41.0
100	8x19	190	230	292	480	280	64.0
150	8x22	241	280	406	600	350	113.0



GLOBE VALVE

STRAIGHT, FLANGED ENDS

467068
ANSI 300

DESCRIPTION: Straight type, forged steel body stop valve, Stellite trim with rising stem and bolted bonnet. Raised face flanged.

APPLICATION: Start/stop and throttling of: Air, water, oils, steam, oils and aggressive/abrasive media etc.

STANDARD & DESIGN:

Design Code: API 602 (DN20-DN40)
BS 1873 (DN50-DN150)
Inspection Std.: API 598
End Std.: ASME B16.5
Face to Face Std.: ASME B16.10
Flanges drilled: ANSI 300(DN20-DN150)
Pressure rating: ANSI 300(DN20-DN150)

VARIATIONS: Other materials and dimensions on request.

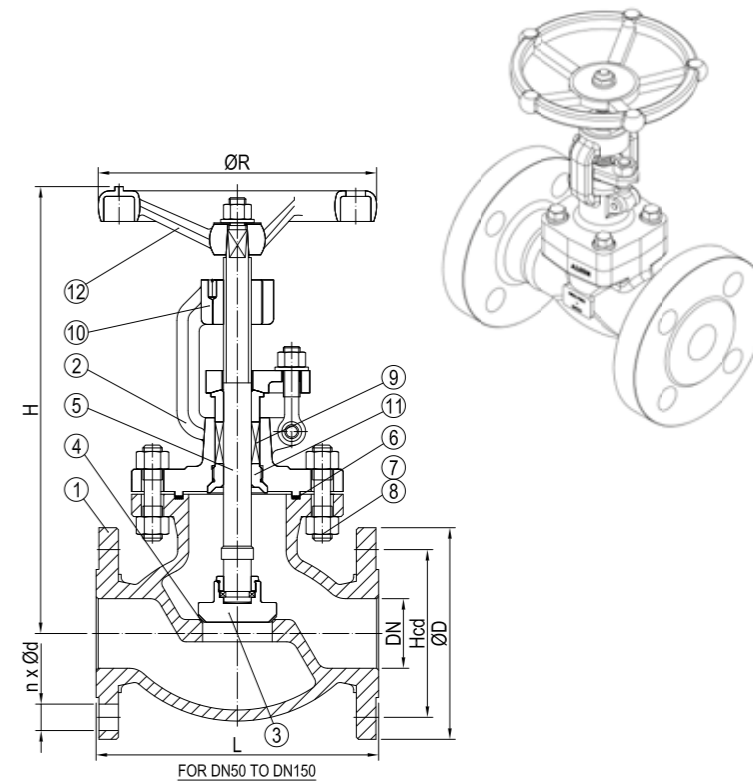

No	Part	Material	Code
1	Body (DN20-DN40)	Forged Steel	ASTM A105
		Cast Steel	ASTM A216-WCB
2	Bonnet (DN20-DN40)	Forged Steel	ASTM A105
		Cast Steel	ASTM A216-WCB
3	Disc (DN20-DN40)	Stainless Steel	ASTM A276-420
		Forged Steel	ASTM A105
4	Seat	Deposited Stellite	-
5	Stem (DN20-DN40)	Stainless Steel	ASTM A276-410
		Stainless Steel	ASTM A182-F6a
6	Bonnet Gasket	Graphite	-
7	Stud Bolt	Steel	ASTM A193 Gr.B7
8	Nut	Steel	ASTM A194 Gr.2H
9	Packing	Graphite	-
10	Stem Nut (DN20-DN40)	Carbon Steel	1045
		Al-Bronze alloy	-
11	Back Seat Bushing	Stainless Steel	ASTM A276-420
12	Handwheel (DN20-DN40)	Malleable Iron	ASTM A197
		Cast Iron	-

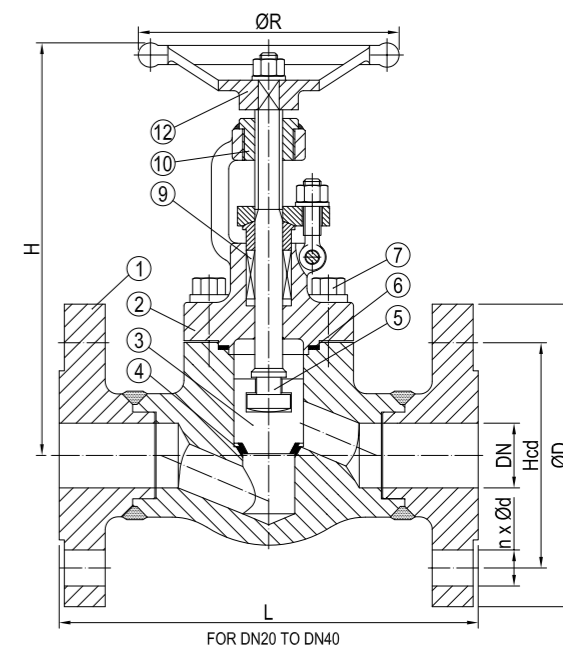

DN	n x ød	Hcd	øD	L	H	øR	Kg
20	4x19	83	115	178	155	100	5.3
25	4x19	89	125	203	176	125	7.2
32	4x19	98	135	216	200	160	10.6
40	4x22	114	155	229	220	160	15.3
50	8x19	127	165	267	370	200	25.0
65	8x22	149	190	292	420	240	32.0
80	8x22	168	210	318	460	240	35.0
100	8x22	200	255	356	480	280	56.0
150	12x22	270	320	444	600	350	120.0



GLOBE VALVE

STRAIGHT, FLANGED ENDS

467097
ANSI 150

DESCRIPTION: Straight type, cast AISI 316 equivalent body. Metal seated screw down stop valve with rising stem, bolted bonnet. Raised face flanged.

APPLICATION: Start/stop and throttling of: Water, steam, oils, acidic media etc.

STANDARD & DESIGN:

Design Code: ASME B16.34
 Inspection Std.: API 598
 End Std.: ASME B16.5
 Face to Face Std.: ASME B16.10
 Flanges drilled: ANSI 150(DN15-DN250)
 Pressure rating: ANSI 150(DN15-DN250)

VARIATIONS: Other materials and dimensions on request.

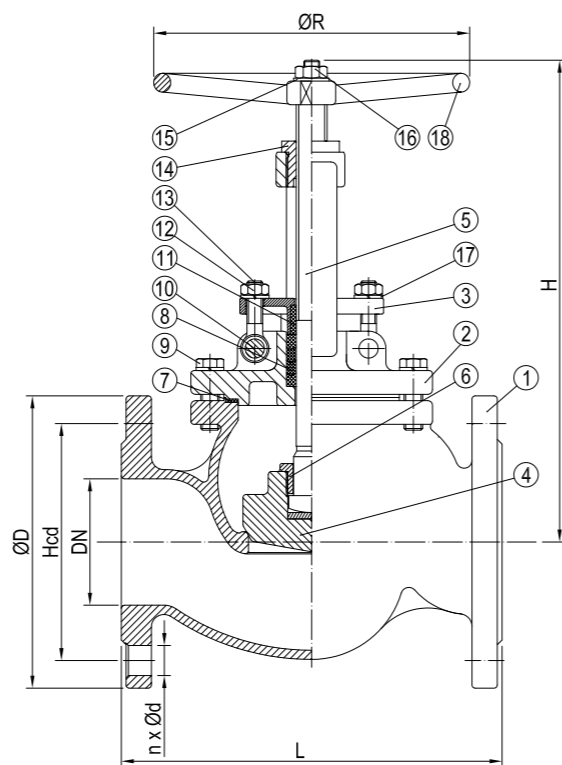
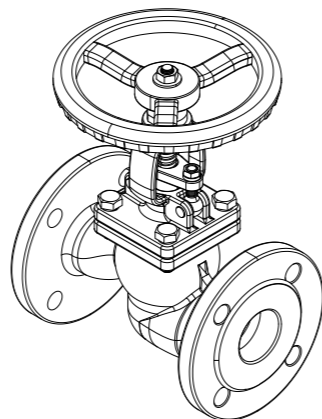
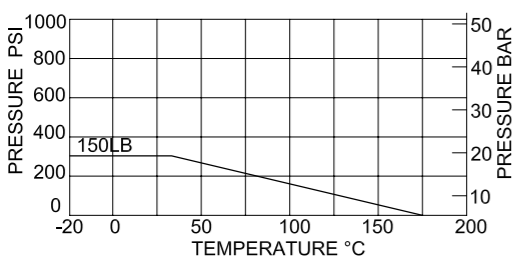

No	Part	Material	Code
1	Body	Stainless Steel	CF8M
2	Bonnet	Stainless Steel	CF8M
3	Gland	Stainless Steel	CF8
4	Disc	Stainless Steel	CF8M
5	Stem	Stainless Steel	SUS 316
6	Disc Cover	Stainless Steel	CF8M
7	Gasket (<200) (≥200)	PTFE Graphite	-
8	Gland Packing	PTFE	-
9	Bolt	Stainless Steel	SUS 304
10	Hinge Pin	Stainless Steel	SUS 304
11	Stem Bushing	PTFE	-
12	Nut	Stainless Steel	SUS 304
13	Eye Bolt	Stainless Steel	SUS 304
14	Yoke Sleeve	Bronze	-
15	Name Plate	Stainless Steel	SUS 304
16	Nut	Stainless Steel	SUS 304
17	Spring Washers	Stainless Steel	SUS 304
18	Hand Wheel	Cast Iron	FCD 400

DN	n x ød	Hcd	øD	L	H	øR	Kg
15	4x16	60	89	108	186	140	3.2
20	4x16	69	98	117	186	140	3.8
25	4x16	80	108	127	212	140	4.4
32	4x16	89	117	140	243	160	6.3
40	4x16	98	127	165	246	160	7.4
50	4x19	121	152	203	252	200	10.6
65	4x19	140	178	216	308	200	15.2
80	4x19	152	190	241	327	250	20.8
100	8x19	190	229	292	384	250	31.0
125	8x22	216	254	356	484	300	47.3
150	8x22	241	279	406	547	350	62.2
200	8x22	298	343	495	669	350	98.9
250	12x25	362	406	622	824	500	188.0



GLOBE VALVE

STRAIGHT, FLANGED ENDS

467098
ANSI 300

DESCRIPTION: Straight type, cast AISI 316 equivalent body. Metal seated screw down stop valve with rising stem, bolted bonnet. Raised face flanged.

APPLICATION: Start/stop and throttling of: Water, steam, oils, acidic media etc.

STANDARD & DESIGN:

Design Code: ASME B16.34
 Inspection Std.: API 598
 End Std.: ASME B16.5
 Face to Face Std.: ASME B16.10
 Flanges drilled: ANSI 300(DN15-DN200)
 Pressure rating: ANSI 300(DN15-DN200)

VARIATIONS: Other materials and dimensions on request.

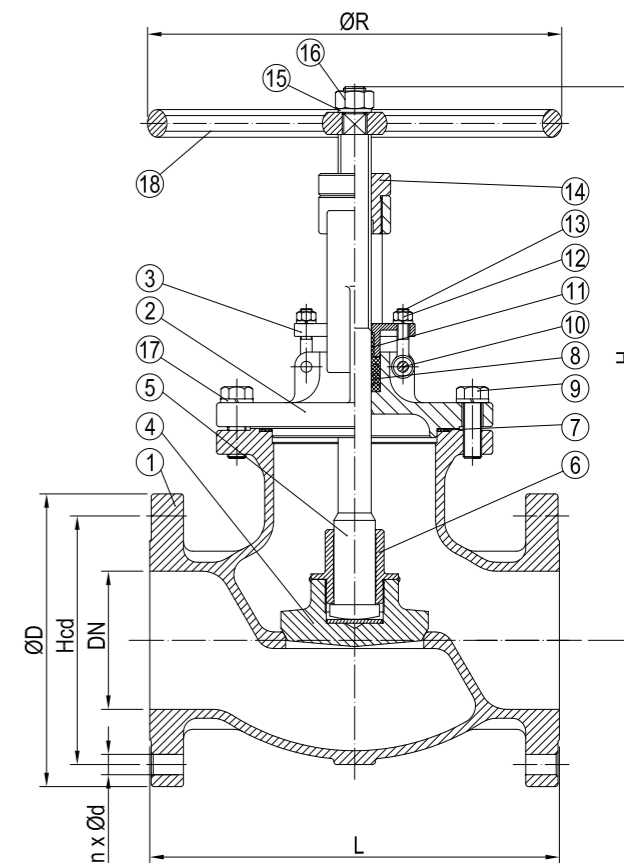
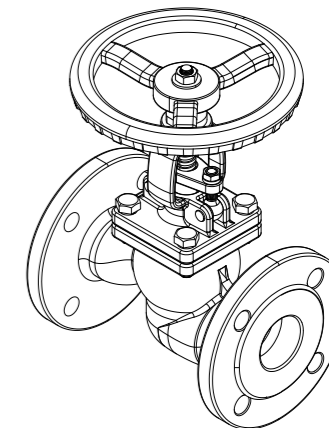
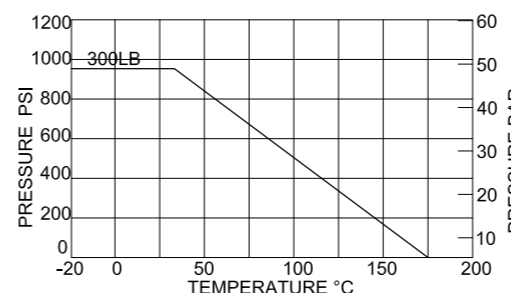

No	Part	Material	Code
1	Body	Stainless Steel	CF8M
2	Bonnet	Stainless Steel	CF8M
3	Gland	Stainless Steel	CF8
4	Disc	Stainless Steel	CF8M
5	Stem	Stainless Steel	SUS 316
6	Disc Cover	Stainless Steel	CF8M
7	Gasket	Graphite	-
8	Gland Packing	PTFE	-
9	Bolt	Stainless Steel	SUS 304
10	Hinge Pin	Stainless Steel	SUS 304
11	Stem Bushing	PTFE	-
12	Nut	Stainless Steel	SUS 304
13	Eye Bolt	Stainless Steel	SUS 304
14	Yoke Sleeve	Bronze	-
15	Name Plate	Stainless Steel	SUS 304
16	Nut	Stainless Steel	SUS 304
17	Spring Washers	Stainless Steel	SUS 304
18	Hand Wheel	Cast Iron	FCD 400

DN	n x ød	Hcd	øD	L	H	øR	Kg
15	4x16	67	95	152	230	140	4.9
20	4x19	83	117	178	230	140	6.1
25	4x19	89	124	203	230	140	6.9
40	4x22	114	156	229	328	250	15.7
50	8x19	127	165	267	378	250	21.8
65	8x22	149	190	292	411	300	28.9
80	8x22	168	210	318	426	300	37.0
100	8x22	200	254	356	520	300	56.7
150	12x22	270	318	444	667	450	109.8
200	12x25	330	381	559	829	500	-



CHECK VALVES

Used to avoid flow in both directions. Often placed in connection with pumps.
Available with threaded, flanged or weld end connections.
Also available in wafer version to be mounted between flanges.
Metal to metal sealing or soft sealing.



DUAL PLATE CHECK VALVE

315197
ANSI 150

DESCRIPTION: Wafer type, AISI 316 equivalent body, spring tensioned dual check valve with NBR soft sealing AISI 316 plates.

APPLICATION: Preventing backflow in water, oil systems etc. Suitable when rapid flow reversal can occur, to prevent hammering.

STANDARD & DESIGN:

Design Code: -
 Inspection Std.: ASME-B16.34/API-598
 End Std.: -
 Face to Face Std.: API-594
 Pressure rating: ANSI 150(DN50-DN300)

VARIATIONS: Seat in EPDM or viton
 Other materials and dimensions on request.

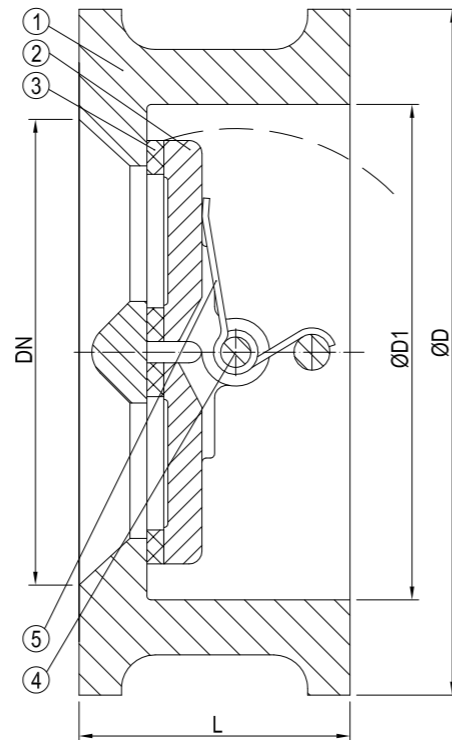
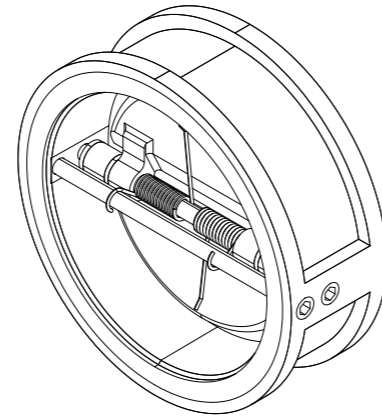

No	Part	Material	Code
1	Body	Stainless Steel	A351 CF8M
2	Disc	Stainless Steel	A351 CF8M
3	Seat	Viton	-
4	Stem	Stainless Steel	SS316
5	Spring	Stainless Steel	SUS316

DN	Inch	øD	øD1	L	Kg
50	2	105	60	60	2
65	2 1/2	124	73	67	3
80	3	137	89	73	4
100	4	175	114	73	6
125	5	197	141	86	7
150	6	222	168	98	10
200	8	279	219	127	20
250	10	340	274	146	32
300	12	410	324	181	49



SWING CHECK VALVE

FLANGED ENDS

370267
ANSI 150

DESCRIPTION: Straight type, cast steel body, full bore swing check valve, Stellite coated seat and disc. Raised face flanged.

APPLICATION: Preventing backflow in water, oil and aggressive media systems etc.

STANDARD & DESIGN:

Design Code: API 594
 Inspection Std.: API 598
 End Std.: ASME B16.5
 Face to Face Std.: ASME B16.10
 Flanges drilled: ANSI 150(DN50-DN300)
 Pressure rating: ANSI 150(DN50-DN300)

VARIATIONS: Other materials and dimensions on request.

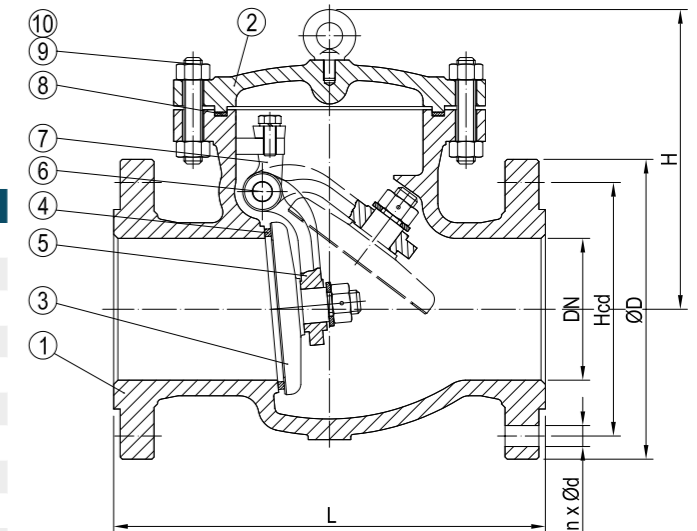
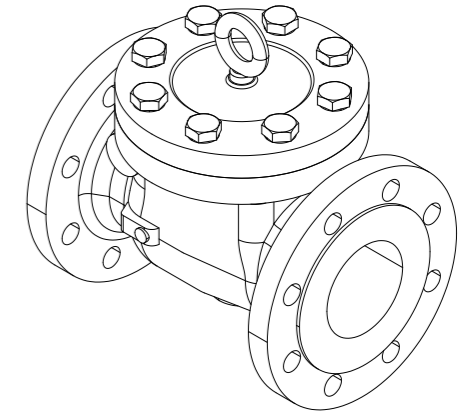

No	Part	Material	Code
1	Body	Cast Steel	ASTM A216-WCB
2	Bonnet	Cast Steel	ASTM A216-WCB
3	Disc	Cast Steel	ASTM A216-WCB
4	Seat	Forged Steel	ASTM A105
5	Hinge	Cast Steel	ASTM A216-WCB
6	Hinge Pin	Stainless Steel	ASTM A276-420
7	Support	Cast Steel	ASTM A216-WCB
8	Gasket	Graphite	-
9	Stud Bolt	Steel	ASTM A193 Gr.B7
10	Nut	Steel	ASTM A194 Gr.2H

DN	n x ød	Hcd	øD	L	H	Kg
50	4x19	121	150	203	161	17
65	4x19	140	180	216	180	23
80	4x19	152	190	241	190	33
100	8x19	190	230	292	220	44
150	8x22	241	280	356	257	78
200	8x22	298	345	495	292	137
250	12x26	362	405	622	350	207
300	12x26	431	485	699	398	279



GATE VALVES

For shut off purposes. Can be delivered with visual position indicator.
Available with threaded, flanged or weld end connections.
Metal to metal sealing or soft sealing.
Available with different types of actuators.



GATE VALVE

FLANGED ENDS

620767
ANSI 150

DESCRIPTION: Cast steel body gate valve with stellite coated steel wedge and stellite coated seat. Rising stem and bolted bonnet. Raised face flanged.

APPLICATION: Start/stop flow with minimized pressure drop for water, steam, oils and aggressive media etc.

STANDARD & DESIGN:

Design Code: API 600
 Inspection Std.: API 598
 End Std.: ASME B16.5
 Face to Face Std.: ASME B16.10
 Flanges drilled: ANSI 150(DN50-DN600)
 Pressure rating: ANSI 150(DN50-DN600)

VARIATIONS: Other dimensions and materials on request.

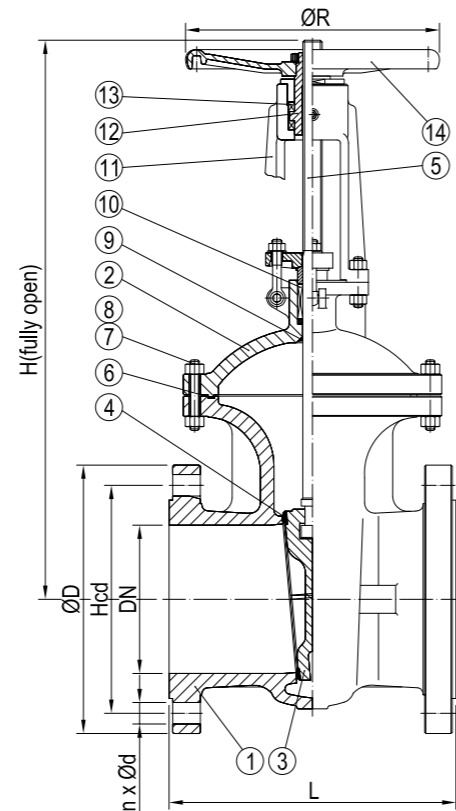
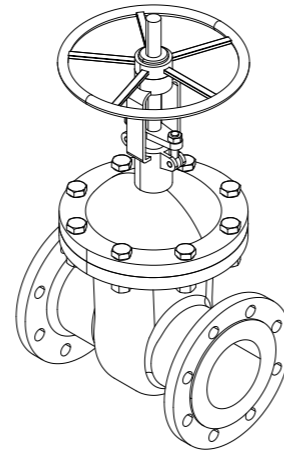

No	Part	Material	Code
1	Body	Cast Steel	ASTM A216-WCB
2	Bonnet	Cast Steel	ASTM A216-WCB
3	Wedge	Cast Steel	ASTM A216-WCB
4	Seat	Forged Steel	ASTM A105
5	Stem	Stainless Steel	ASTM A182-F6a
6	Bonnet Gasket	Graphite	-
7	Stud Bolt	Steel	ASTM A193 Gr.B7
8	Nut	Steel	ASTM A194 Gr.2H
9	Back Seat Bushing	Stainless Steel	ASTM A276-420
10	Packing	Graphite	-
11	Yoke	Cast Steel	ASTM A216-WCB
12	Stem Nut	Al-Bronze alloy	-
13	Axle tree	Steel	E51100
14	Handwheel	Cast Iron	-

DN	n x ød	Hcd	øD	L	H	øR	Kg
50	4x19	121	150	178	323	200	18
65	4x19	140	180	191	347	250	28
80	4x19	152	190	203	383	250	30
100	8x19	190	230	229	457	300	50
125	8x22	216	255	254	632	300	63
150	8x22	241	280	267	635	350	85
200	8x22	298	345	292	762	350	128
250	12x26	362	405	330	895	400	220
300	12x26	431	485	356	1080	500	310
350	12x29	476	535	381	1295	600	450
400	16x29	540	595	406	1435	600	550
450	16x32	578	635	432	1626	650	700
500	20x32	635	700	457	1829	650	910
600	20x35	749	815	508	2175	700	1130



GATE VALVE

FLANGED ENDS

620768
ANSI 300

DESCRIPTION: Cast steel body gate valve with stellite coated steel wedge and stellite coated seat. Rising stem and bolted bonnet. Raised face flanged.

APPLICATION: Start/stop flow with minimized pressure drop for water, steam, oils and aggressive/abrasive media etc.

STANDARD & DESIGN:

Design Code: API 600
 Inspection Std.: API 598
 End Std.: ASME B16.5
 Face to Face Std.: ASME B16.10
 Flanges drilled: ANSI 300(DN50-DN300)
 Pressure rating: ANSI 300(DN50-DN300)

VARIATIONS: Other dimensions and materials on request.

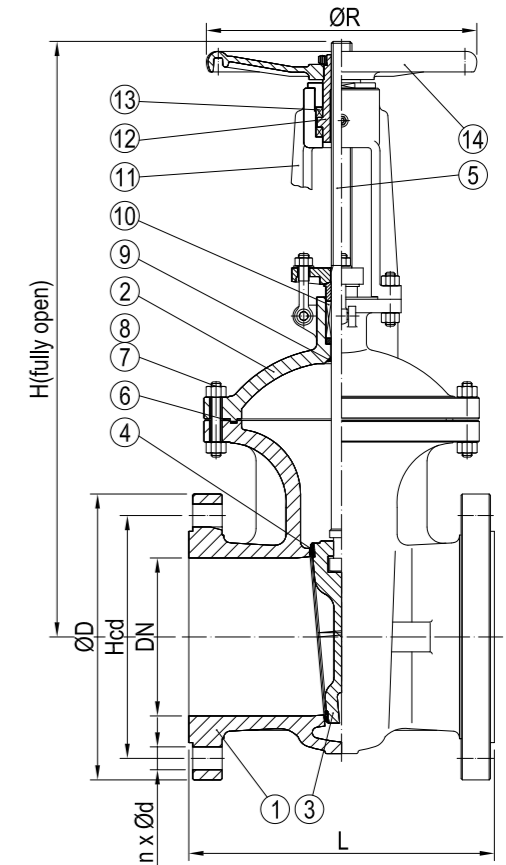
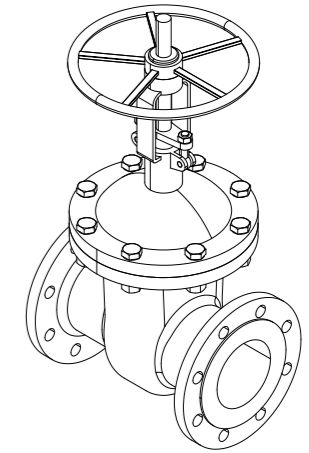

No	Part	Material	Code
1	Body	Cast Steel	ASTM A216-WCB
2	Bonnet	Cast Steel	ASTM A216-WCB
3	Wedge	Cast Steel	ASTM A216-WCB
4	Seat	Forged Steel	ASTM A105
5	Stem	Stainless Steel	ASTM A182-F6a
6	Bonnet Gasket	Graphite	-
7	Stud Bolt	Steel	ASTM A193 Gr.B7
8	Nut	Steel	ASTM A194 Gr.2H
9	Back Seat Bushing	Stainless Steel	ASTM A276-420
10	Packing	Graphite	-
11	Yoke	Cast Steel	ASTM A216-WCB
12	Stem Nut	Al-Bronze alloy	-
13	Axle tree	Steel	E51100
14	Handwheel	Cast Iron	-

DN	n x ød	Hcd	øD	L	H	øR	Kg
50	8x19	127	165	216	330	250	30
65	8x22	149	190	241	368	250	36
80	8x22	168	210	283	394	300	61
100	8x22	200	255	305	473	300	77
125	8x22	235	280	381	660	350	106
150	12x22	270	320	403	711	350	153
200	12x26	330	380	419	813	400	286
250	16x29	387	445	457	1003	500	412
300	16x32	450	520	502	1137	600	576



STRAINERS

For filtration of dirt or particles in a diversified range of fluids. Straight, angle and Y-patterns.
Available with flanged or threaded connections.
Available with screen perforation in different mesh sizes.
Tailor made galvanized filters according to customer specification also available.



STRAINER

Y-TYPE, FLANGED ENDS

483497
ANSI 150

DESCRIPTION: Y-type, AISI 316 equivalent body strainer with AISI 316 strainer basket. Raised face flanged.

APPLICATION: Filtering of water, oils, process liquids in general etc.

STANDARD & DESIGN:

Design Code: ASME B16.34
 Inspection Std.: API 598
 End Std.: ASME B16.5
 Face to Face Std.: ASME B16.10
 Flanges Drilled: ANSI 150 (DN15-DN300)
 Pressure rating: ANSI 150 (DN15-DN300)
 Mesh size: 20 mesh

VARIATIONS:

Other mesh sizes.
 Other materials on request.

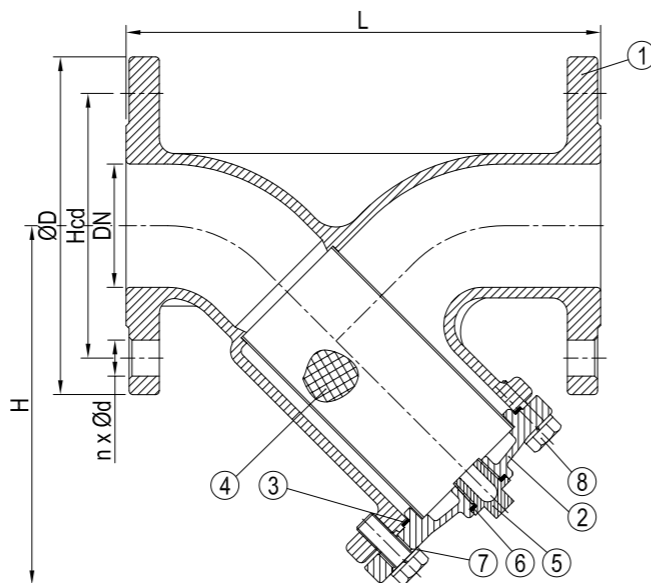
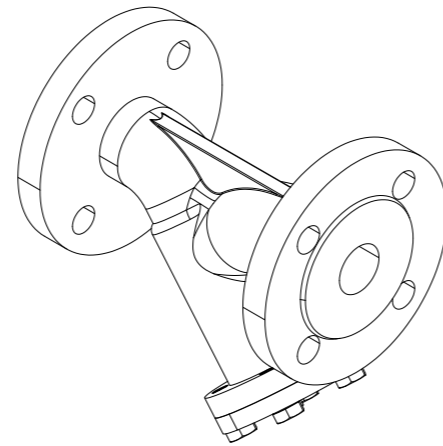

No	Part	Material	Code
1	Body	Stainless Steel	CF8M
2	Cap	Stainless Steel	CF8M
3	Gasket	PTFE	-
4	Screen	Stainless Steel	SUS 316
5	Stopper	Stainless Steel	CF8M
6	Gasket	PTFE	-
7	Spring Washers	Stainless Steel	SUS 304
8	Bonnet Bolt	Stainless Steel	SUS 304

DN	n x ød	Hcd	øD	L	H	Kg
15	4x16	60	89	108	85	2.3
20	4x16	69	98	117	87	2.8
25	4x16	80	108	127	114	3.9
32	4x16	89	117	140	114	5.3
40	4x16	98	127	165	135	6.3
50	4x19	121	152	203	155	8.3
65	4x19	140	178	216	189	11.8
80	8x19	152	190	241	200	15.6
100	8x19	190	229	292	232	21.0
125	8x22	216	254	356	274	29.0
150	8x22	241	279	406	326	41.0
200	8x22	298	343	495	397	73.4
250	12x25	362	406	622	512	128.0
300	12x25	400	485	699	562	184.0



STRAINER

Y-TYPE, FLANGED ENDS

483498
ANSI 300

DESCRIPTION: Y-type, AISI 316 equivalent body strainer with AISI 316 strainer basket. Raised face flanged.

APPLICATION: Filtering of water, oils, process liquids in general etc.

STANDARD & DESIGN:

Design Code: ASME B16.34
 Inspection Std.: API 598
 End Std.: ASME B16.5
 Face to Face Std.: ASME B16.10
 Flanges Drilled: ANSI 300 (DN15-DN300)
 Pressure rating: ANSI 300 (DN15-DN300)
 Mesh size: 20 mesh

VARIATIONS:

Other mesh sizes.
 Other materials on request.

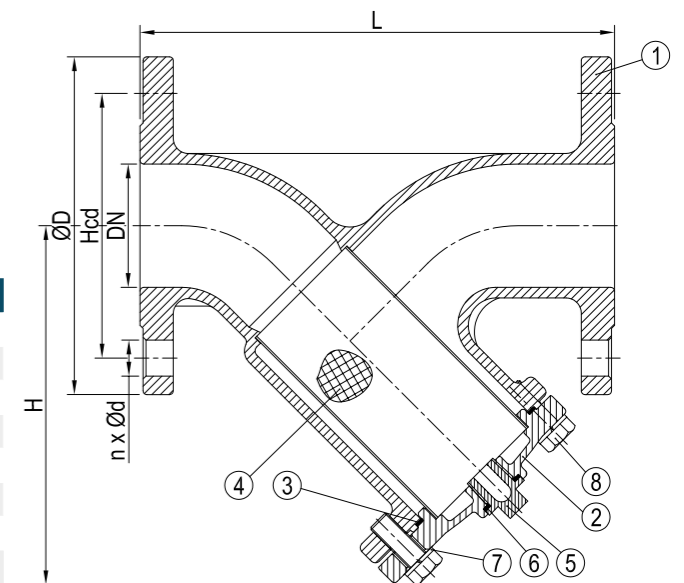
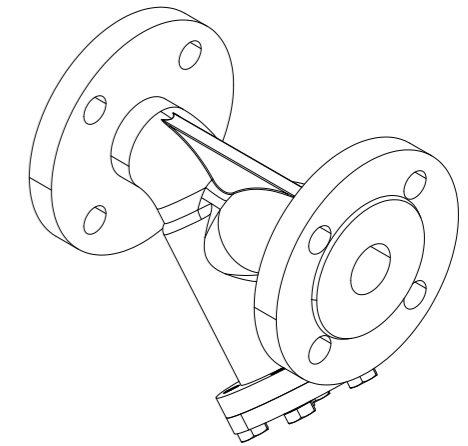

No	Part	Material	Code
1	Body	Stainless Steel	CF8M
2	Cap	Stainless Steel	CF8M
3	Gasket	PTFE	-
4	Screen	Stainless Steel	SUS 316
5	Stopper	Stainless Steel	CF8M
6	Gasket	PTFE	-
7	Spring Washers	Stainless Steel	SUS 304
8	Bonnet Bolt	Stainless Steel	SUS 304

DN	n x ød	Hcd	øD	L	H	Kg
15	4x16	67	95	140	85	2.3
20	4x19	83	117	152	87	2.8
25	4x19	80	124	165	114	3.9
32	4x19	98	133	178	114	5.3
40	4x22	121	156	190	135	6.3
50	8x19	140	165	216	155	8.3
65	8x22	152	190	241	189	11.8
80	8x22	190	210	283	200	15.6
100	8x22	241	254	305	232	21.0
150	12x22	298	318	403	326	41.0
200	12x25	295	381	502	397	73.4
250	16x29	387	444	568	512	128.0
300	16x32	450	521	648	562	184.0



BASKET STRAINER

FLANGED ENDS

483667
ANSI 150

DESCRIPTION: Straight type cast steel body strainer with AISI 304 strainer basket. With drain plug. Raised face flanged.

APPLICATION: Filtering of water, oils, process liquids etc.

STANDARD & DESIGN:

Design Code: ASME B16.34/EN12516-1
 Inspection Std.: API 598
 End Std.: ANSI B16.5 CLASS 150 RF
 Face to Face Std.: -
 Flanges Drilled: ANSI 150(DN25-DN300)
 Pressure rating: ANSI 150(DN25-DN300)
 Mesh size: 40 mesh

VARIATIONS: Other mesh sizes

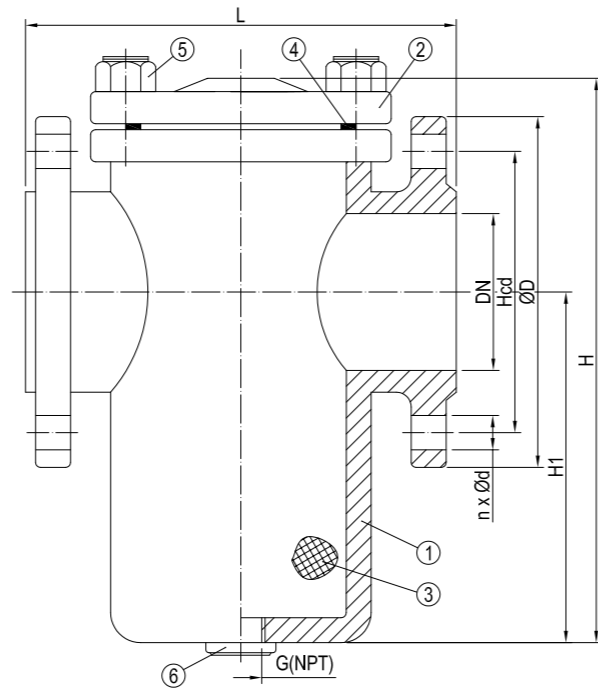
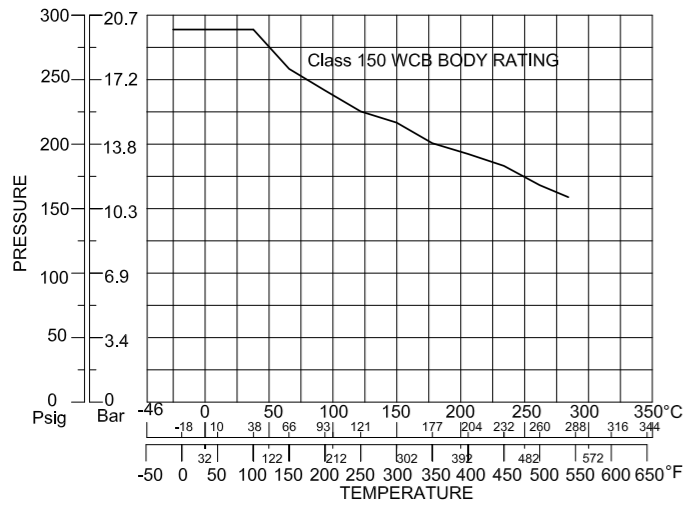
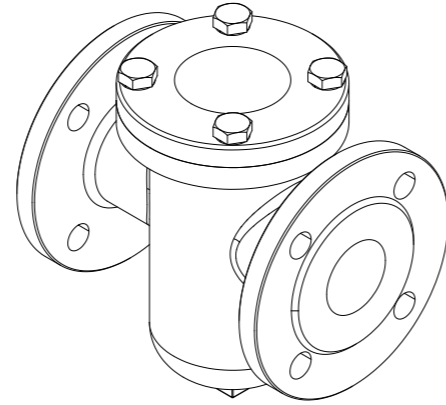

No	Part	Material	Code
1	Body	Cast Steel	ASTM A216 Gr.WCB
2	Cap	Cast Steel	ASTM A216 Gr.WCB
3	Screen	Stainless Steel	SUS 304
4	Gasket	PTFE	-
5	Bolt	Steel	ASTM A193 B7
6	Plug	Cast Steel	ASTM A216 Gr.WCB

DN	n x ød	Hcd	øD	G(Inch)	L	H	H1	Kg
25	4x18	80	108	1/2	152	174	77	6.6
40	4x18	98	127	1/2	164	216	120	9
50	4x20	121	152	1	210	216	120	13
65	4x20	140	178	1	222	260	160	15
80	4x20	152	190	1	252	306	200	21
100	8x20	190	229	1	293	390	254	31
125	8x22	216	254	1	336	430	280	49
150	8x22	241	279	1	380	410	270	50
200	8x22	298	343	1	478	560	340	77
250	12x25	362	406	2	508	685	360	143
300	12x25	431	483	2	666	760	420	199



BASKET STRAINER

FLANGED ENDS

483697
ANSI 150

DESCRIPTION: Straight type AISI 316 equivalent body strainer with AISI 304 strainer basket. With drain plug. Raised face flanged.

APPLICATION: Filtering of water, oils, process liquids etc.

STANDARD & DESIGN:

Design Code: ASME B16.34/EN12516-1
 Inspection Std.: API 598
 End Std.: ANSI B16.5 CLASS 150 RF
 Face to Face Std.: -
 Flanges Drilled: ANSI 150(DN25-DN300)
 Pressure rating: ANSI 150(DN25-DN300)
 Mesh size: 40 mesh

VARIATIONS: Other mesh sizes

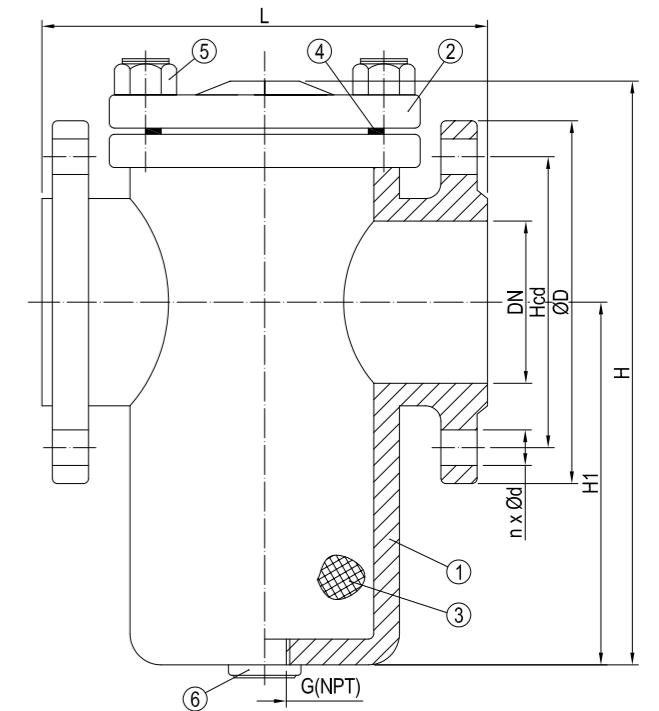
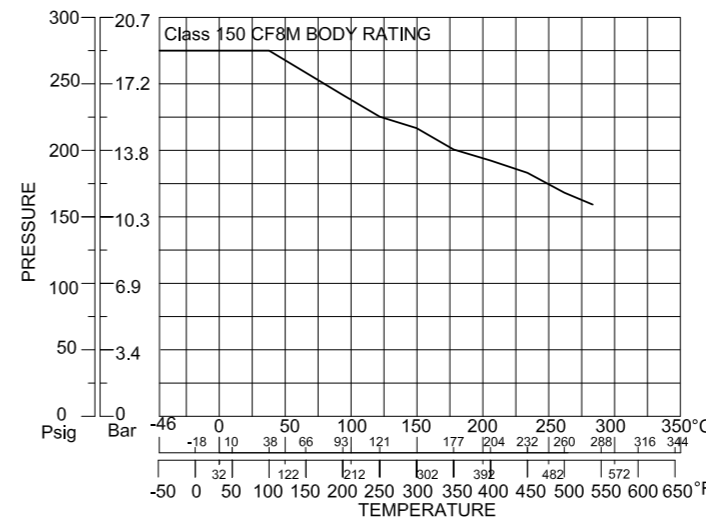
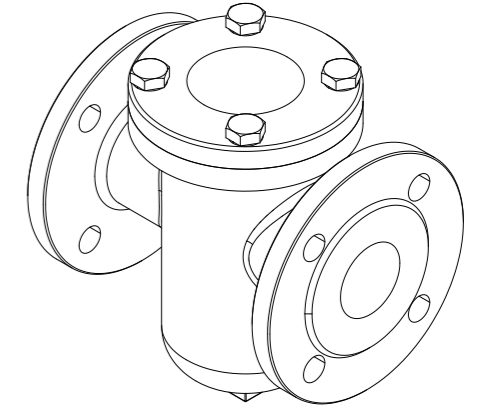

No	Part	Material	Code
1	Body	Stainless Steel	ASTM A351 Gr.CF8M
2	Cap	Stainless Steel	ASTM A351 Gr.CF8M
3	Screen	Stainless Steel	SUS 304
4	Gasket	PTFE	-
5	Bolt	Steel	ASTM A193 B8
6	Plug	Stainless Steel	ASTM A351 Gr.CF8

DN	n x ød	Hcd	øD	G(Inch)	L	H	H1	Kg
25	4x18	80	108	1/2	152	174	77	6.6
40	4x18	98	127	1/2	164	216	120	9
50	4x20	121	152	1	210	216	120	13
65	4x20	140	178	1	222	260	160	15
80	4x20	152	190	1	252	306	200	21
100	8x20	190	229	1	293	390	254	31
125	8x22	216	254	1	336	430	280	49
150	8x22	241	279	1	380	410	270	50
200	8x22	298	343	1	478	560	340	77
250	12x25	362	406	2	508	685	360	143
300	12x25	431	483	2	666	760	420	199



BALL VALVES

For shut off purposes. Can also be delivered as 3-way and 4-way valves.
Available with threaded, flanged or weld end connections.
Metal to metal sealing or soft sealing.
Available with different types of actuators.



BALL VALVE

2-PC., FULL BORE, FLANGED ENDS

445167
ANSI 150

DESCRIPTION: Two piece, full bore, cast steel body ball valve with AISI 316 ball and PTFE seat ring. Raised face flanged.

APPLICATION: Start/stop flow of: Compressed air, gases and liquids. Typically also used for drain and vent purposes.

STANDARD & DESIGN:

Design Code: ASME B16.34
 Inspection Std.: API 598
 End Std.: ASME B16.5
 Face to Face Std.: ASME B16.10
 Top Flange: ISO 5211(DN15-DN300)
 Flanges drilled: ANSI 150(DN15-DN300)
 Pressure rating: ANSI 150(DN15-DN300)

VARIATIONS: Various actuators
 Available as Fire Safe version.
 Other dimensions and materials on request.
 With direct mounting pad.

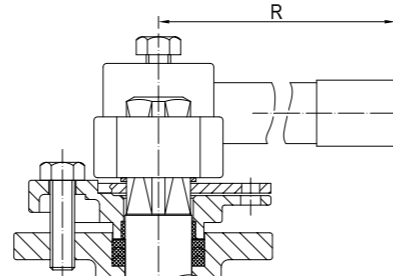
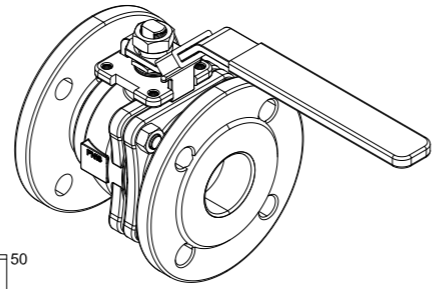
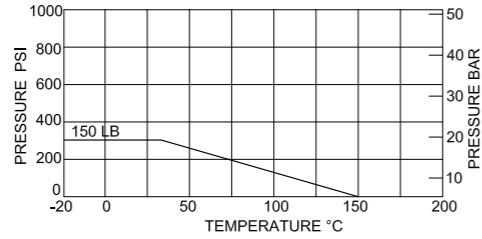

FOR DN125 TO DN300

No	Part	Material	Code
1	Body	Carbon Steel	WCB
2	Cap	Carbon Steel	WCB
3	Gland	Stainless Steel	SUS 304
4	Ball	Stainless Steel	CF8
5	Seat	PTFE	-
6	Stem	Stainless Steel	SUS 304
7	Bonnet Gasket	PTFE	-
8	Thrust Washer	PTFE	TFM4215
9	Packing	PTFE	-
10	Spring Washer	Stainless Steel	SUS 304
11	Stem Nut	Stainless Steel	SUS 304
12	Locking Device	Stainless Steel	SUS 304
13	Bolt	Carbon Steel	-
14	Nut	Carbon Steel	-
15	Handle Cover	Plastic	-
16	Handle	Stainless Steel	SUS304

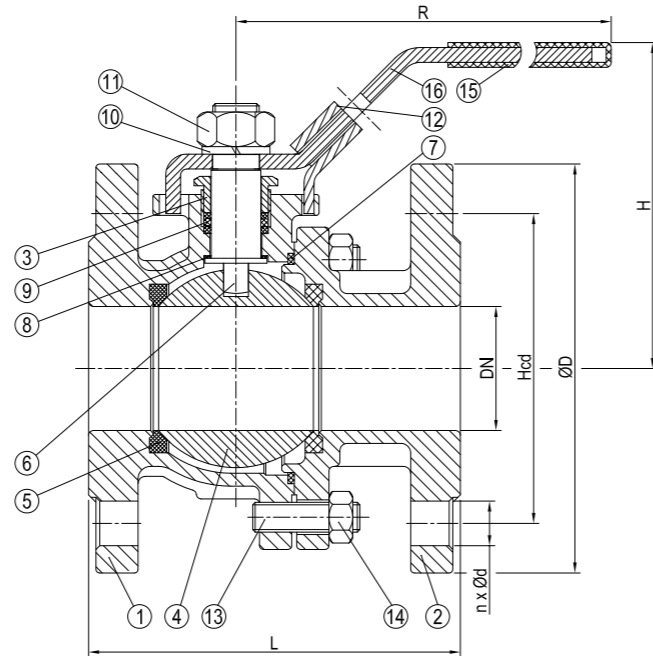

DN	n x ød	Hcd	øD	L	H	R	Kg
15	4x16	60	89	108	76	153	1.5
20	4x16	69	98	117	78	153	2.1
25	4x16	80	108	127	92	188	2.9
32	4x16	89	117	140	95	188	3.5
40	4x16	98	127	165	126	245	5.5
50	4x19	121	152	178	132	245	8.4
65	4x19	140	178	190	166	288	13.0
80	4x19	152	190	203	176	288	16.4
100	8x19	190	229	229	190	388	28.3
125	8x22	216	254	356	224	750	46.0
150	8x22	241	279	394	247	750	63.6
200	8x22	298	343	457	305	1000	97.5
250	12x25	362	406	533	327	1000	196.5
300	12x25	431	483	610	355	1000	305.0



BALL VALVE

2-PC., FULL BORE, FLANGED ENDS

445168
ANSI 300

DESCRIPTION: Two piece, full bore, cast steel body ball valve with AISI 316 ball and PTFE seat ring. Raised face flanged.

APPLICATION: Start/stop flow of: Compressed air, gases and liquids. Typically also used for drain and vent purposes.

STANDARD & DESIGN:

Design Code: ASME B16.34
 Inspection Std.: API 598
 End Std.: ASME B16.5
 Face to Face Std.: ASME B16.10
 Top Flange: ISO 5211(DN15-DN300)
 Flanges drilled: ANSI 300(DN15-DN300)
 Pressure rating: ANSI 300(DN15-DN300)

VARIATIONS: Various actuators
 Available as Fire Safe version.
 Other dimensions and materials on request.
 With direct mounting pad.

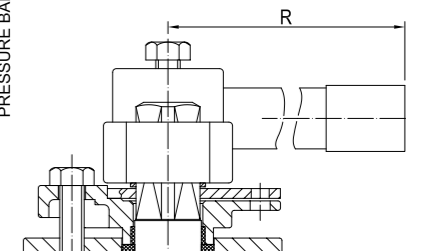
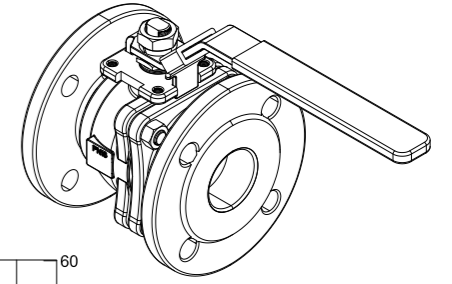
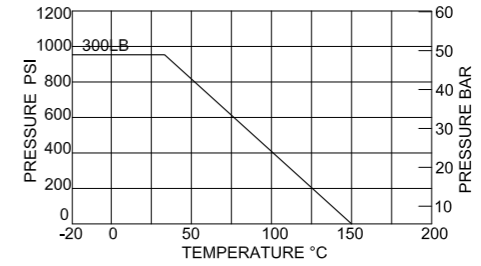

FOR DN125 TO DN300

No	Part	Material	Code
1	Body	Carbon Steel	WCB
2	Cap	Carbon Steel	WCB
3	Gland	Stainless Steel	SUS 304
4	Ball	Stainless Steel	CF8
5	Seat	PTFE	-
6	Stem	Stainless Steel	SUS 304
7	Bonnet Gasket	PTFE	-
8	Thrust Washer	PTFE	TFM4215
9	Packing	PTFE	-
10	Spring Washer	Stainless Steel	SUS 304
11	Stem Nut	Stainless Steel	SUS 304
12	Locking Device	Stainless Steel	SUS 304
13	Bolt	Carbon Steel	-
14	Nut	Carbon Steel	-
15	Handle Cover	Plastic	-
16	Handle	Stainless Steel	SUS304

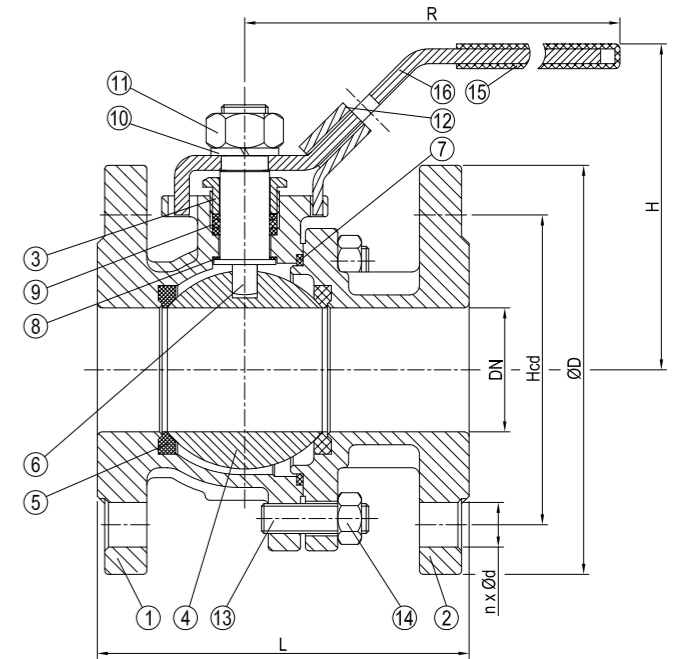

DN	n x ød	Hcd	øD	L	H	R	Kg
15	4x16	67	95	140	76	153	2.4
20	4x19	83	117	152	78	153	3.3
25	4x19	89	124	165	92	188	4.7
32	4x19	98	133	178	95	188	6.2
40	4x22	114	156	190	126	245	8.9
50	8x19	127	165	216	132	245	12.1
65	8x22	149	190	241	166	288	18.2
80	8x22	168	210	283	176	288	25.4
100	8x22	200	254	305	190	388	27.9
150	12x22	270	318	403	247	750	84.0
200	12x25	330	381	502	305	1000	154.0
250	16x29	387	444	568	327	1000	289.0
300	16x32	450	521	648	355	1000	357.0



BALL VALVE

2-PC., FULL BORE, FLANGED ENDS

445197
ANSI 150

DESCRIPTION: Two piece, full bore, AISI 316 equivalent body ball valve with AISI 316 ball and PTFE seat ring. Raised face flanged.

APPLICATION: Start/stop flow of: Compressed air, gases and liquids. Typically also used for drain and vent purposes.

STANDARD & DESIGN:

Design Code: ASME B16.34
 Inspection Std.: API 598
 End Std.: ASME B16.5
 Face to Face Std.: ASME B16.10
 Top Flange: ISO 5211(DN15-DN300)
 Flanges drilled: ANSI 150(DN15-DN300)
 Pressure rating: ANSI 150(DN15-DN300)

VARIATIONS: Various actuators Available as Fire Safe version. Other dimensions and materials on request. With direct mounting pad.

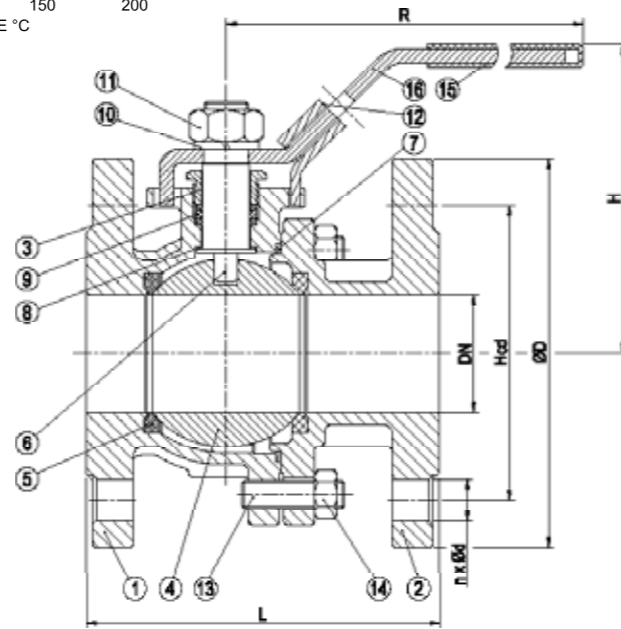
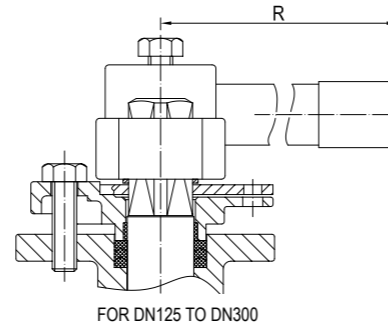
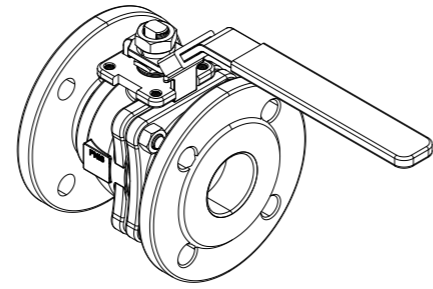
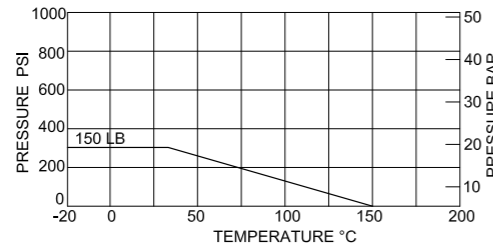

No	Part	Material	Code
1	Body	Stainless Steel	CF8M
2	Cap	Stainless Steel	CF8M
3	Gland	Stainless Steel	SUS 304
4	Ball	Stainless Steel	CF8M
5	Seat	PTFE	-
6	Stem	Stainless Steel	SUS 316
7	Bonnet Gasket	PTFE	-
8	Thrust Washer	PTFE	TFM4215
9	Packing	PTFE	-
10	Spring Washer	Stainless Steel	SUS 304
11	Stem Nut	Stainless Steel	SUS 304
12	Locking Device	Stainless Steel	SUS 304
13	Bolt	Stainless Steel	SUS 304
14	Nut	Stainless Steel	SUS 304
15	Handle Cover	Plastic	-
16	Handle	Stainless Steel	SUS304

DN	n x ød	Hcd	øD	L	H	R	Kg
15	4x16	60	89	108	76	153	1.5
20	4x16	69	98	117	78	153	2.1
25	4x16	80	108	127	92	188	2.9
32	4x16	89	117	140	95	188	3.5
40	4x16	98	127	165	126	245	5.5
50	4x19	121	152	178	132	245	8.4
65	4x19	140	178	190	166	288	13.1
80	4x19	152	190	203	176	288	16.4
100	8x19	190	229	229	190	388	28.3
125	8x22	216	254	356	224	750	46.0
150	8x22	241	279	394	247	750	63.6
200	8x22	298	343	457	305	1000	97.5
250	12x25	362	406	533	327	1000	196.5
300	12x25	431	483	610	355	1000	305.0



BALL VALVE

2-PC., FULL BORE, FLANGED ENDS

445198
ANSI 300

DESCRIPTION: Two piece, full bore, AISI 316 equivalent body ball valve with AISI 316 ball and PTFE seat ring. Raised face flanged.

APPLICATION: Start/stop flow of: Compressed air, gases and liquids. Typically also used for drain and vent purposes.

STANDARD & DESIGN:

Design Code: ASME B16.34
 Inspection Std.: API 598
 End Std.: ASME B16.5
 Face to Face Std.: ASME B16.10
 Top Flange: ISO 5211(DN15-DN300)
 Flanges drilled: ANSI 300(DN15-DN300)
 Pressure rating: ANSI 300(DN15-DN300)

VARIATIONS: Various actuators Available as Fire Safe version. Other dimensions and materials on request. With direct mounting pad.

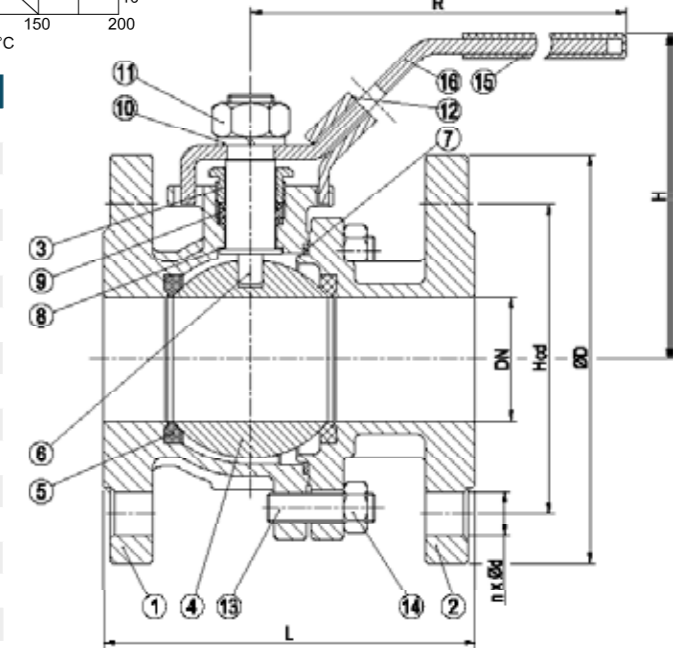
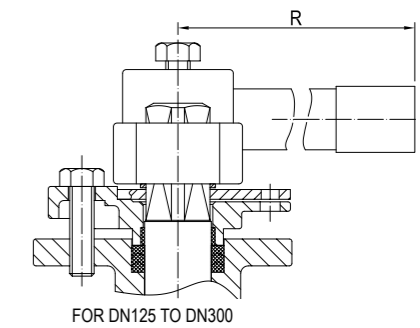
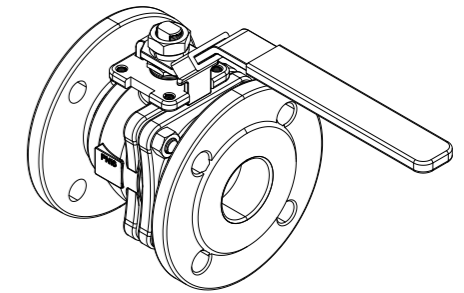
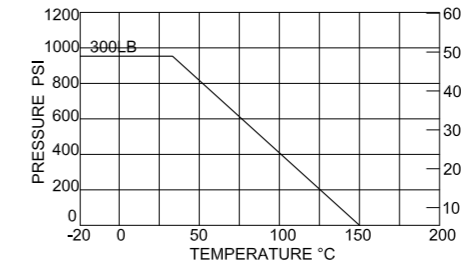

No	Part	Material	Code
1	Body	Stainless Steel	CF8M
2	Cap	Stainless Steel	CF8M
3	Gland	Stainless Steel	SUS 304
4	Ball	Stainless Steel	CF8M
5	Seat	PTFE	-
6	Stem	Stainless Steel	SUS 316
7	Bonnet Gasket	PTFE	-
8	Thrust Washer	PTFE	TFM4215
9	Packing	PTFE	-
10	Spring Washer	Stainless Steel	SUS 304
11	Stem Nut	Stainless Steel	SUS 304
12	Locking Device	Stainless Steel	SUS 304
13	Bolt	Stainless Steel	SUS 304
14	Nut	Stainless Steel	SUS 304
15	Handle Cover	Plastic	-
16	Handle	Stainless Steel	SUS304

DN	n x ød	Hcd	øD	L	H	R	Kg
15	4x16	67	95	140	76	153	2.4
20	4x19	83	117	152	78	153	3.3
25	4x19	89	124	165	92	188	4.7
32	4x19	98	133	178	95	188	6.2
40	4x22	114	156	190	126	245	8.9
50	8x19	127	165	216	132	245	12.1
65	8x22	149	190	241	166	288	18.2
80	8x22	168	210	283	176	288	25.4
100	8x22	200	254	305	190	388	27.9
150	12x22	270	318	403	247	750	84.0
200	12x25	330	381	502	305	1000	154.0
250	16x29	387	444	568	327	1000	289.0
300	16x32	450	521	648	355	1000	357.0

JIS

VALVES ACCORDING TO JAPANESE INDUSTRIAL STANDARD (JIS).

The valves in this section mainly follow the normative dimensions and pressure classes from the mentioned standardization organization. If not found here you may find the type of valve suitable for your need in other sections as well and we may also have the possibility to adopt a valve to fit your needs. Don't hesitate to contact us with any inquiry.





STOP VALVES

For shut off and regulating purposes.
Can be delivered with non-return disc or regulating disc.
Available with threaded, flanged or weld end connections.
Metal to metal sealing or soft sealing.
Available with different types of actuators.



GLOBE VALVE

STRAIGHT, FLANGED ENDS

F-7301/F-7351
JIS 5K

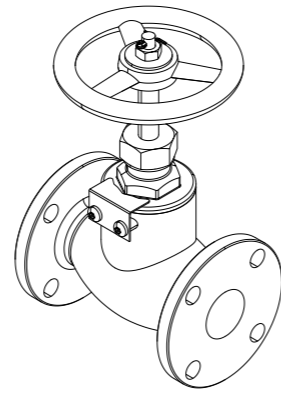

DESCRIPTION: Straight type, Rg5 body, metal seated screw down stop valve with rising stem, screwed and secured bonnet. Flat face flanged.

APPLICATION: Start/stop and throttling of: Sea water, water and oils etc.

STANDARD & DESIGN:

Design Code: JIS F7301
 Inspection Std.: JIS F7400
 End Std.: JIS B2240
 Face to Face Std.: -
 Pressure rating: JIS 5K(DN15-DN65)

VARIATIONS:

F-7301=Fixed Disc
 F-7351=SDNR

Other dimensions and materials on request.

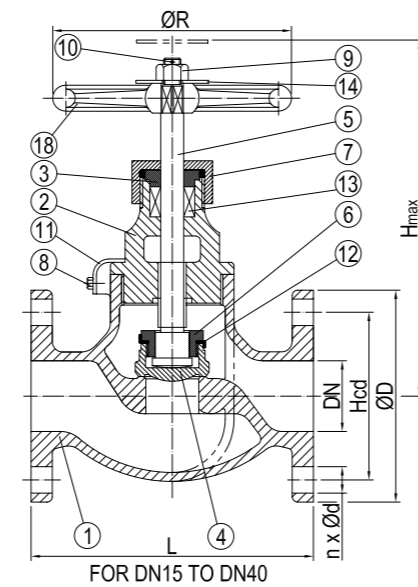
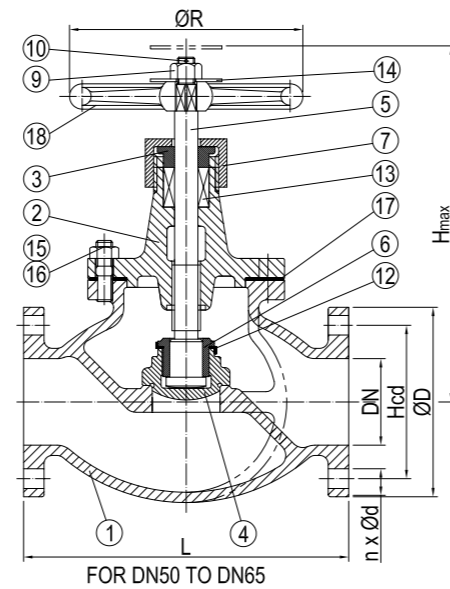

No	Part	Material	Code
1	Body	Bronze	BC 6
2	Bonnet (<=DN40)	Brass	C 3771 BE
	(>=DN50)	Bronze	BC6
3	Gland	Brass	C 3771 BE
4	Disc (<=DN40)	Brass	C 3771 BE
	(>=DN50)	Bronze	BC6
5	Stem	Brass	C 3771 BE
6	Disc Nut	Brass	C 3771 BE
7	Gland Nut	Brass	C 3771 BE
8	Machine Screw	Stainless Steel	SUS 304
9	Hexagonal Nut	Stainless Steel	SUS 304
10	Split Pin	Brass	C 2600 W
11	Lock Plate	Brass	C 2600 P
12	Disc Lock Washer	Brass	C 2600 P
13	Packing	Graphite	-
14	Name Plate	Aluminium	Al
15	Stud	Brass	C 3771 BE
16	Hexagonal Nut	Brass	C 3771 BE
17	Gasket	Asbestos free	-
18	Handwheel	Cast Iron	FC 200

DN	n x ød	Hcd	øD	L	H _{max}	øR	Kg
15	4x12	60	80	100	130	80	2.0
20	4x12	65	85	110	140	100	2.9
25	4x12	75	95	120	160	125	3.5
32	4x15	90	115	140	170	125	5.0
40	4x15	95	120	160	190	140	6.5
50	4x15	105	130	210	235	140	11.7
65	4x15	130	155	250	260	160	17.0



GLOBE VALVE

ANGLE TYPE, FLANGED ENDS

F-7302/F-7352
JIS 5K

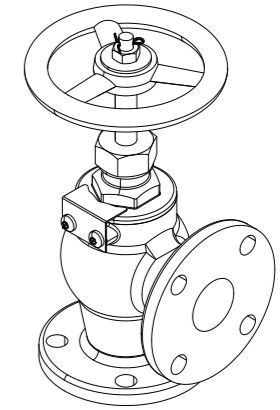

DESCRIPTION: Angled type, Rg5 body, metal seated screw down stop valve with rising stem, screwed and secured bonnet. Flat face flanged.

APPLICATION: Start/stop and throttling of: Sea water, water and oils etc.

STANDARD & DESIGN:

Design Code: JIS F7302
 Inspection Std.: JIS F7400
 End Std.: JIS B2240
 Face to Face Std.: -
 Pressure rating: JIS 5K(DN15-DN65)

VARIATIONS:

F-7302=Fixed Disc
 F-7352=SDNR

Other dimensions and materials on request.

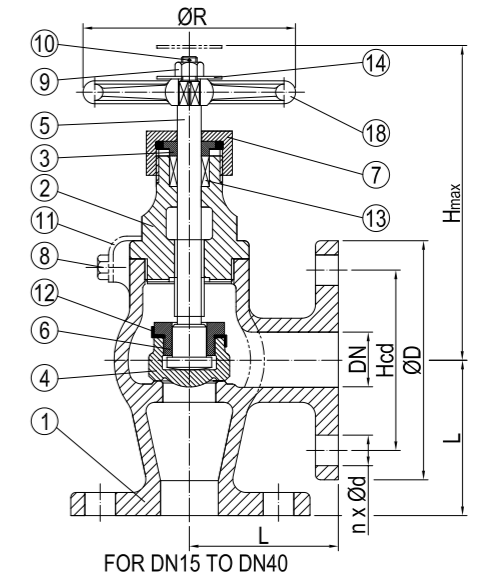
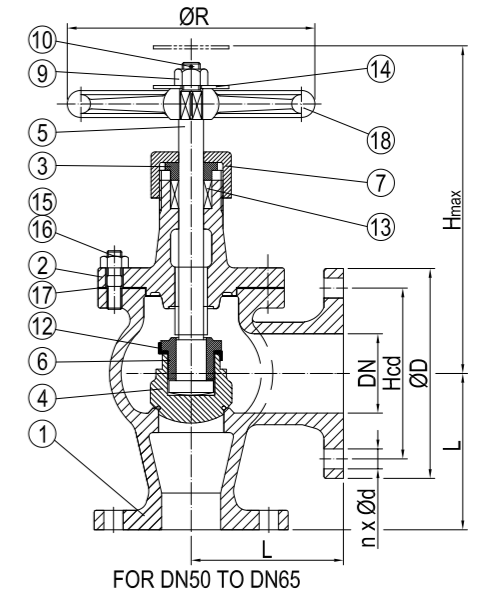

No	Part	Material	Code
1	Body	Bronze	BC 6
2	Bonnet (<=DN40)	Brass	C 3771 BE
	(>=DN50)	Bronze	BC6
3	Gland	Brass	C 3771 BE
4	Disc (<=DN40)	Brass	C 3771 BE
	(>=DN50)	Bronze	BC6
5	Stem	Brass	C 3771 BE
6	Disc Nut	Brass	C 3771 BE
7	Gland Nut	Brass	C 3771 BE
8	Machine Screw	Stainless Steel	SUS 304
9	Hexagonal Nut	Stainless Steel	SUS 304
10	Split Pin	Brass	C 2600 W
11	Lock Plate	Brass	C 2600 P
12	Disc Lock Washer	Brass	C 2600 P
13	Packing	Graphite	-
14	Name Plate	Aluminium	Al
15	Stud	Brass	C 3771 BE
16	Hexagonal Nut	Stainless Steel	SUS 304
17	Gasket	Asbestos free	-
18	Handwheel	Cast Iron	FC 200

DN	n x ød	Hcd	øD	L	H _{max}	øR	Kg
15	4x12	60	80	55	120	80	2.0
20	4x12	65	85	60	130	100	2.7
25	4x12	75	95	65	145	125	3.4
32	4x15	90	115	80	150	125	4.8
40	4x15	95	120	85	165	140	6.0
50	4x15	105	130	100	200	140	10.1
65	4x15	130	155	115	220	160	15.6



GLOBE VALVE

STRAIGHT, FLANGED ENDS

F-7303/F-7409
JIS 16K

DESCRIPTION: Straight type, Rg5 body, metal seated screw down stop valve with rising stem, screwed and secured bonnet. Flat face flanged.

APPLICATION: Start/stop and throttling of: Sea water, water and oils etc.

STANDARD & DESIGN:

Design Code: JIS F7303
 Inspection Std.: JIS F7400
 End Std.: JIS B2240
 Face to Face Std.: -
 Pressure rating: JIS 16K(DN15-DN40)

VARIATIONS:

F-7303=Fixed Disc
 F-7409=SDNR

Other dimensions and materials on request.

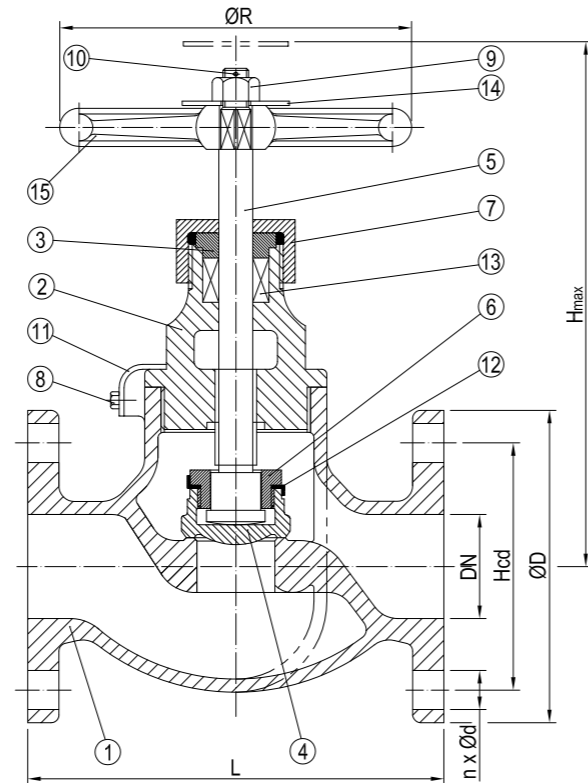
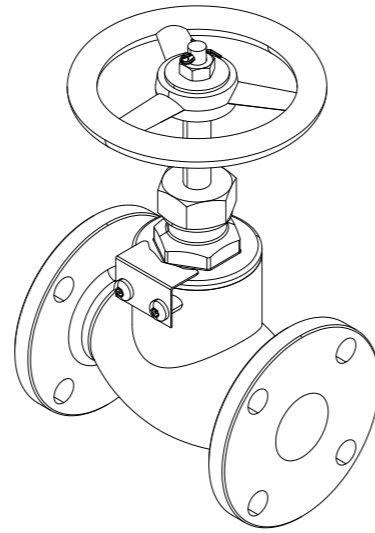

No	Part	Material	Code
1	Body	Bronze	BC 6
2	Bonnet	Brass	C3771 BE
3	Gland	Brass	C3771 BE
4	Disc	Brass	C3771 BE
5	Stem	Brass	C3771 BE
6	Disc Nut	Brass	C3771 BE
7	Gland Nut	Brass	C3771 BE
8	Machine Screw	Stainless Steel	SUS 304
9	Hexagonal Nut	Stainless Steel	SUS 304
10	Split Pin	Brass	C2600 W
11	Lock Plate	Brass	C2600 P
12	Disc Lock Washer	Brass	C2600 P
13	Packing	Graphite	-
14	Name Plate	Aluminium	Al
15	Handwheel	Cast Iron	FC 200

DN	n x ød	Hcd	øD	L	H _{max}	øR	Kg
15	4x15	70	95	110	130	80	2.8
20	4x15	75	100	120	140	100	3.7
25	4x19	90	125	130	160	125	5.2
32	4x19	100	135	160	170	125	6.9
40	4x19	105	140	180	190	140	8.4



GLOBE VALVE

ANGLE TYPE, FLANGED ENDS

F-7304/F-7410
JIS 16K

DESCRIPTION: Angled type, Rg5 body, metal seated screw down stop valve with rising stem, screwed and secured bonnet. Flat face flanged.

APPLICATION: Start/stop and throttling of: Sea water, water and oils etc.

STANDARD & DESIGN:

Design Code: JIS F7304
 Inspection Std.: JIS F7400
 End Std.: JIS B2240
 Face to Face Std.: -
 Pressure rating: JIS 16K(DN15-DN40)

VARIATIONS:

F-7304=Fixed Disc
 F-7410=SDNR

Other dimensions and materials on request.

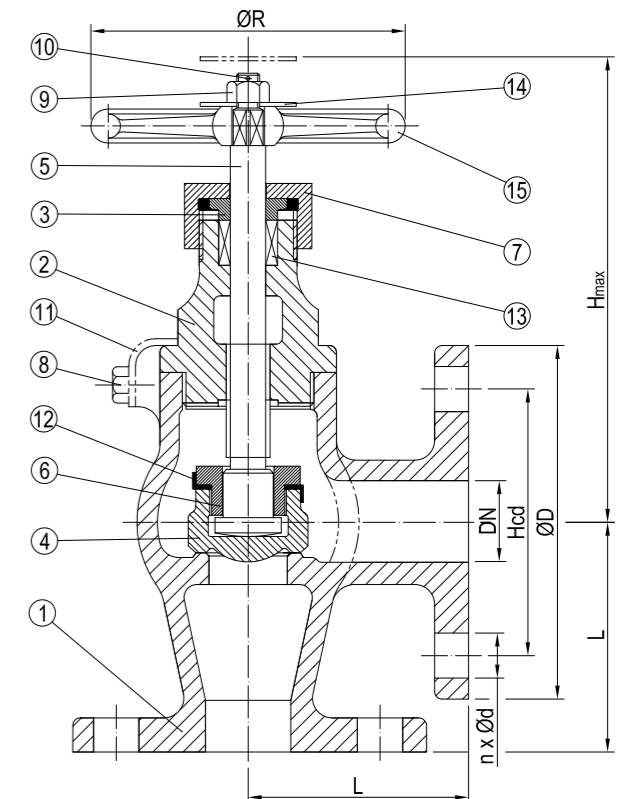
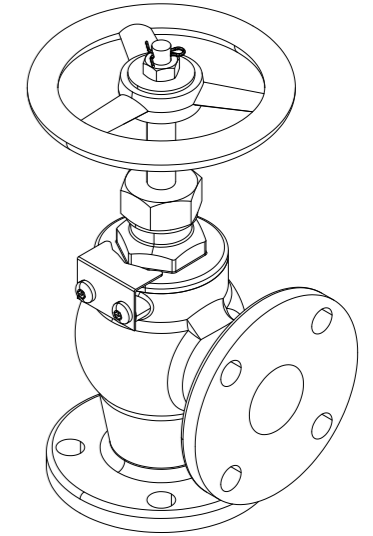

No	Part	Material	Code
1	Body	Bronze	BC 6
2	Bonnet	Brass	C3771 BE
3	Gland	Brass	C3771 BE
4	Disc	Brass	C3771 BE
5	Stem	Brass	C3771 BE
6	Disc Nut	Brass	C3771 BE
7	Gland Nut	Brass	C3771 BE
8	Machine Screw	Stainless Steel	SUS 304
9	Hexagonal Nut	Stainless Steel	SUS 304
10	Split Pin	Brass	C2600 W
11	Lock Plate	Brass	C2600 P
12	Disc Lock Washer	Brass	C2600 P
13	Packing	Graphite	-
14	Name Plate	Aluminium	Al
15	Handwheel	Cast Iron	FC 200

DN	n x ød	Hcd	øD	L	H _{max}	øR	Kg
15	4x15	70	95	70	120	80	2.7
20	4x15	75	100	75	130	100	3.7
25	4x19	90	125	85	145	125	5.2
32	4x19	100	135	95	150	125	6.7
40	4x19	105	140	100	165	140	8.1



GLOBE VALVE

STRAIGHT, FLANGED ENDS

F-7305/F-7353
JIS 5K

DESCRIPTION: Straight type, grey cast iron body, metal seated screw down stop valve with rising stem, bolted bonnet. Flat face flanged.

APPLICATION: Start/stop and throttling of: Sea water, water and oils etc.

STANDARD & DESIGN:

Design Code: JIS F7305
 Inspection Std.: JIS F7400
 End Std.: JIS B2220
 Face to Face Std.: -
 Flanges Drilled: JIS 5K(DN50-DN400)
 Pressure rating: JIS 5K(DN50-DN400)

VARIATIONS: Available with Stainless Steel (2Cr13) trim
 F-7305=Fixed Disc
 F-7353=SDNR

Other dimensions and materials on request.

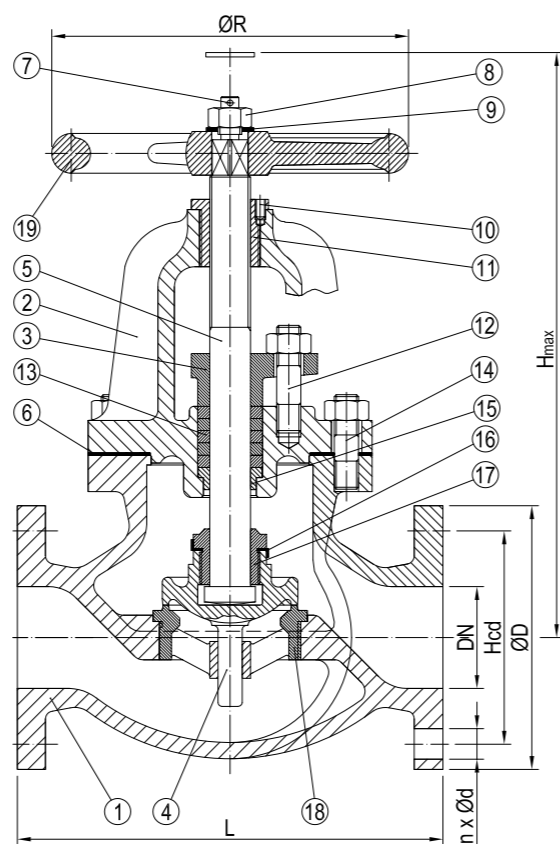
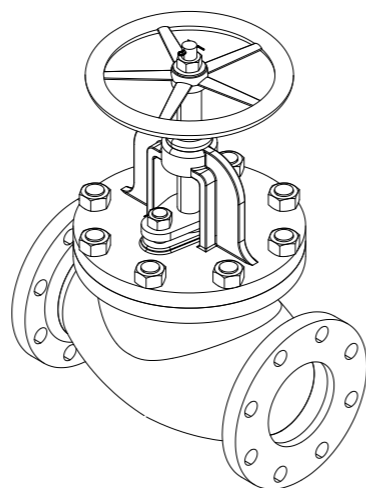

No	Part	Material	Code
1	Body	Cast Iron	HT200
2	Bonnet	Cast Iron	HT200
3	Gland	Brass	H62
4	Disc	Bronze	ZCuSn5Pb5Zn5
5	Stem	Brass	H62
6	Gasket	Graphite	-
7	Split Pin	Carbon Steel	A3
8	Nut	Carbon Steel	Q235A
9	Gasket Ring	Carbon Steel	Q235A
10	Screw	Carbon Steel	Q235A
11	Screwed Bonnet Bush	Brass	H62
12	Double Open End Bolt	Carbon Steel	Q235A
13	Packing	Graphite	-
14	Double Open End Bolt	Carbon Steel	Q235A
15	Packing Seat	Brass	H62
16	Check Washer	Brass	H62
17	Disc Nut	Brass	H62
18	Sealing Ring	Bronze	ZCuSn5Pb5Zn5
19	Handwheel	Cast Iron	HT200

DN	n x ød	Hcd	øD	L	H _{max}	øR	Kg
50	4x15	105	130	210	270	160	14.7
65	4x15	130	155	250	300	180	21.3
80	4x19	145	180	280	310	180	27.7
100	8x19	165	200	340	360	224	40.8
125	8x19	200	235	410	390	250	57.6
150	8x19	230	265	480	445	280	80.3
200	8x23	280	320	570	530	315	139.0
250	12x23	345	385	740	650	355	246.0
300	12x23	390	430	840	740	400	377.0
350	12x25	435	480	940	840	500	-
400	16x25	495	540	1050	940	560	620.0



GLOBE VALVE

ANGLE TYPE, FLANGED ENDS

F-7306/F-7354
JIS 5K

DESCRIPTION: Angled type, grey cast iron body, metal seated screw down stop valve with rising stem, bolted bonnet. Flat face flanged.

APPLICATION: Start/stop and throttling of: Sea water, water and oils etc.

STANDARD & DESIGN:

Design Code: JIS F7306
 Inspection Std.: JIS F7400
 End Std.: JIS B2220
 Face to Face Std.: -
 Flanges Drilled: JIS 5K(DN50-DN400)
 Pressure rating: JIS 5K(DN50-DN400)

VARIATIONS: Available with Stainless Steel (2Cr13) trim
 F-7306=Fixed Disc
 F-7354=SDNR

Other dimensions and materials on request.

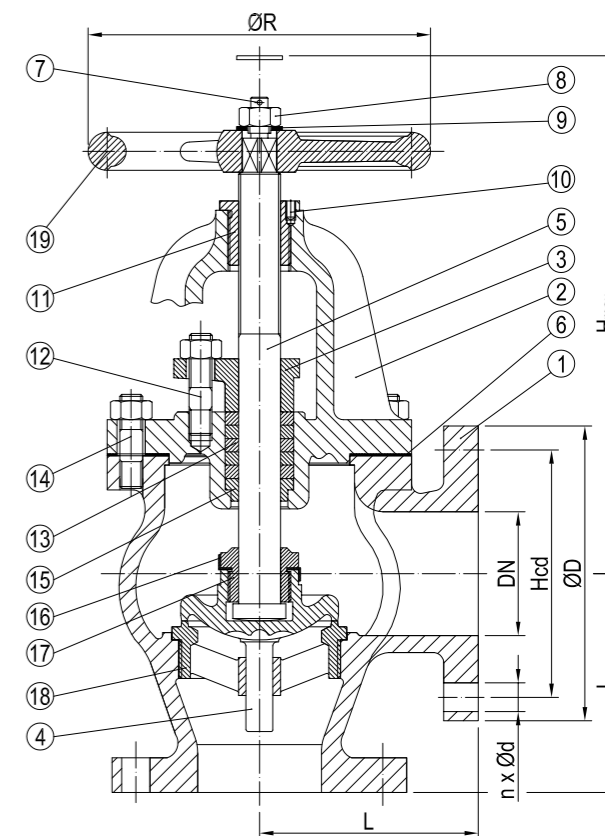
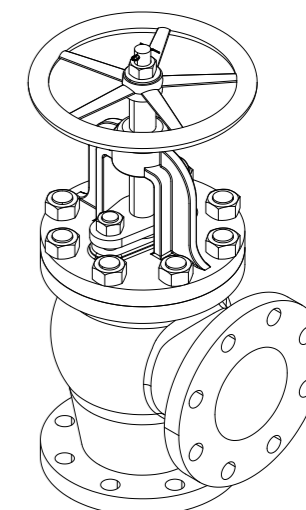

No	Part	Material	Code
1	Body	Cast Iron	HT200
2	Bonnet	Cast Iron	HT200
3	Gland	Brass	H62
4	Disc	Bronze	ZCuSn5Pb5Zn5
5	Stem	Brass	H62
6	Gasket	Graphite	-
7	Split Pin	Carbon Steel	A3
8	Nut	Carbon Steel	Q235A
9	Gasket Ring	Carbon Steel	Q235A
10	Screw	Carbon Steel	Q235A
11	Screwed Bonnet Bush	Brass	H62
12	Double Open End Bolt	Carbon Steel	Q235A
13	Packing	Graphite	-
14	Double Open End Bolt	Carbon Steel	Q235A
15	Packing Seat	Brass	H62
16	Check Washer	Brass	H62
17	Disc Nut	Brass	H62
18	Sealing Ring	Bronze	ZCuSn5Pb5Zn5
19	Handwheel	Cast Iron	HT200

DN	n x ød	Hcd	øD	L	H _{max}	øR	Kg
50	4x15	105	130	100	240	160	12.9
65	4x15	130	155	115	255	180	18.2
80	4x19	145	180	130	265	180	23.4
100	8x19	165	200	150	310	224	33.7
125	8x19	200	235	170	330	250	46.2
150	8x19	230	265	190	380	280	63.4
200	8x23	280	320	220	450	315	105.0
250	12x23	345	385	275	540	355	176.0
300	12x23	390	430	310	610	400	243.0
350	12x25	435	480	360	690	500	-
400	16x25	495	540	395	770	560	-



GLOBE VALVE

STRAIGHT, FLANGED ENDS

F-7307/F-7375
JIS 10K

DESCRIPTION: Straight type, grey cast iron body, metal seated screw down stop valve with rising stem, bolted bonnet. Flat face flanged.

APPLICATION: Start/stop and throttling of: Sea water, water and oils etc.

STANDARD & DESIGN:

Design Code: JIS F7307
 Inspection Std.: JIS F7400
 End Std.: JIS B2220
 Face to Face Std.: -
 Flanges Drilled: JIS 10K(DN50-DN300)
 Pressure rating: JIS 10K(DN50-DN300)

VARIATIONS: Available with Stainless Steel (2Cr13) trim
 F-7307=Fixed Disc
 F-7375=SDNR

Other dimensions and materials on request.

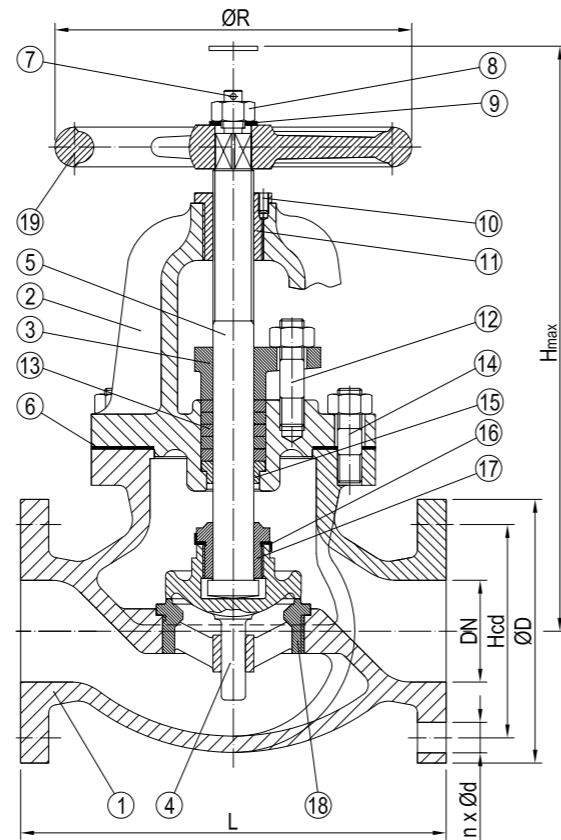
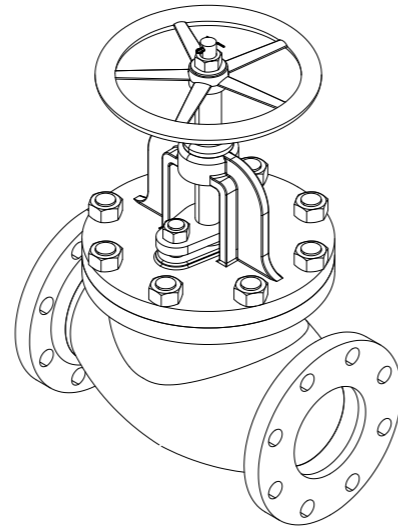

No	Part	Material	Code
1	Body	Cast Iron	HT200
2	Bonnet	Cast Iron	HT200
3	Gland	Brass	H62
4	Disc	Bronze	ZCuSn5Pb5Zn5
5	Stem	Brass	H62
6	Gasket	Graphite	-
7	Split Pin	Carbon Steel	A3
8	Nut	Carbon Steel	Q235A
9	Gasket Ring	Carbon Steel	Q235A
10	Screw	Carbon Steel	Q235A
11	Screwed Bonnet Bush	Brass	H62
12	Double Open End Bolt	Carbon Steel	Q235A
13	Packing	Graphite	-
14	Double Open End Bolt	Carbon Steel	Q235A
15	Packing Seat	Brass	H62
16	Check Washer	Brass	H62
17	Disc Nut	Brass	H62
18	Sealing Ring	Bronze	ZCuSn5Pb5Zn5
19	Handwheel	Cast Iron	HT200

DN	n x ød	Hcd	øD	L	H _{max}	øR	Kg
50	4x19	120	155	220	285	160	19.9
65	4x19	140	175	270	310	200	28.7
80	8x19	150	185	300	320	200	32.4
100	8x19	175	210	350	370	250	48.7
125	8x23	210	250	420	420	280	73.1
150	8x23	240	280	490	470	315	104.0
200	12x23	290	330	570	555	355	162.0
250	12x25	355	400	740	680	450	304.0
300	16x25	400	445	840	770	500	-



GLOBE VALVE

ANGLE TYPE, FLANGED ENDS

F-7308/F-7376
JIS 10K

DESCRIPTION: Angled type, grey cast iron body, metal seated screw down stop valve with rising stem, bolted bonnet. Flat face flanged.

APPLICATION: Start/stop and throttling of: Sea water, water and oils etc.

STANDARD & DESIGN:

Design Code: JIS F7308
 Inspection Std.: JIS F7400
 End Std.: JIS B2220
 Face to Face Std.: -
 Flanges Drilled: JIS 10K(DN50-DN400)
 Pressure rating: JIS 10K(DN50-DN400)

VARIATIONS: Available with Stainless Steel (2Cr13) trim
 F-7308=Fixed Disc
 F-7376=SDNR

Other dimensions and materials on request.

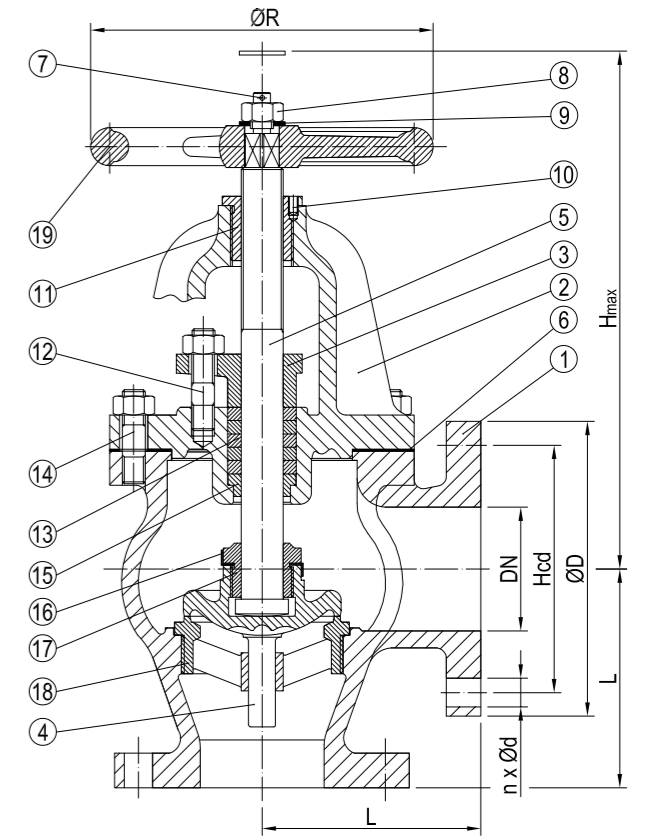
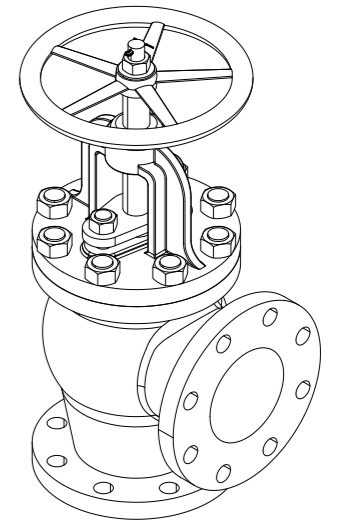

No	Part	Material	Code
1	Body	Cast Iron	HT200
2	Bonnet	Cast Iron	HT200
3	Gland	Brass	H62
4	Disc	Bronze	ZCuSn5Pb5Zn5
5	Stem	Brass	H62
6	Gasket	Graphite	-
7	Split Pin	Carbon Steel	A3
8	Nut	Carbon Steel	Q235A
9	Gasket Ring	Carbon Steel	Q235A
10	Screw	Carbon Steel	Q235A
11	Screwed Bonnet Bush	Brass	H62
12	Double Open End Bolt	Carbon Steel	Q235A
13	Packing	Graphite	-
14	Double Open End Bolt	Carbon Steel	Q235A
15	Packing Seat	Brass	H62
16	Check Washer	Brass	H62
17	Disc Nut	Brass	H62
18	Sealing Ring	Bronze	ZCuSn5Pb5Zn5
19	Handwheel	Cast Iron	HT200

DN	n x ød	Hcd	øD	L	H _{max}	øR	Kg
50	4x19	120	155	120	255	160	18.2
65	4x19	140	175	130	270	200	25.4
80	8x19	150	185	140	275	200	27.4
100	8x19	175	210	160	315	250	40.6
125	8x23	210	250	180	360	280	69.9
150	8x23	240	280	205	405	315	81.0
200	12x23	290	330	213	475	355	125.0
250	12x25	355	400	290	570	450	211.0
300	16x25	400	445	320	645	500	-
350	16x25	445	490	360	710	560	-
400	16x27	510	560	420	790	630	-



GLOBE VALVE

STRAIGHT, FLANGED ENDS

F-7309/F-7377
JIS 16K

DESCRIPTION: Straight type, grey cast iron body, metal seated screw down stop valve with rising stem, bolted bonnet. Flat face flanged.

APPLICATION: Start/stop and throttling of: Sea water, water and oils etc.

STANDARD & DESIGN:

Design Code: JIS F7309
 Inspection Std.: JIS F7400
 End Std.: JIS B2220
 Face to Face Std.: -
 Flanges Drilled: JIS 16K(DN50-DN200)
 Pressure rating: JIS 16K(DN50-DN200)

VARIATIONS: Available with Stainless Steel (2Cr13) trim
 F-7309=Fixed Disc
 F-7377=SDNR
 Other dimensions and materials on request.

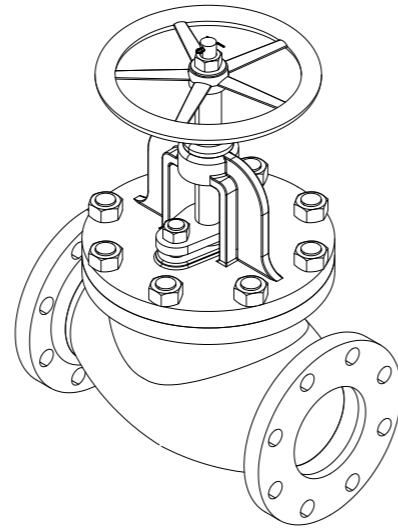

No	Part	Material	Code
1	Body	Cast Iron	HT200
2	Bonnet	Cast Iron	HT200
3	Gland	Brass	H62
4	Disc	Bronze	ZCuSn5Pb5Zn5
5	Stem	Brass	H62
6	Gasket	Graphite	-
7	Split Pin	Carbon Steel	A3
8	Nut	Carbon Steel	Q235A
9	Gasket Ring	Carbon Steel	Q235A
10	Screw	Carbon Steel	Q235A
11	Screwed Bonnet Bush	Brass	H62
12	Double Open End Bolt	Carbon Steel	Q235A
13	Packing	Graphite	-
14	Double Open End Bolt	Carbon Steel	Q235A
15	Packing Seat	Brass	H62
16	Check Washer	Brass	H62
17	Disc Nut	Brass	H62
18	Sealing Ring	Bronze	ZCuSn5Pb5Zn5
19	Handwheel	Cast Iron	HT200

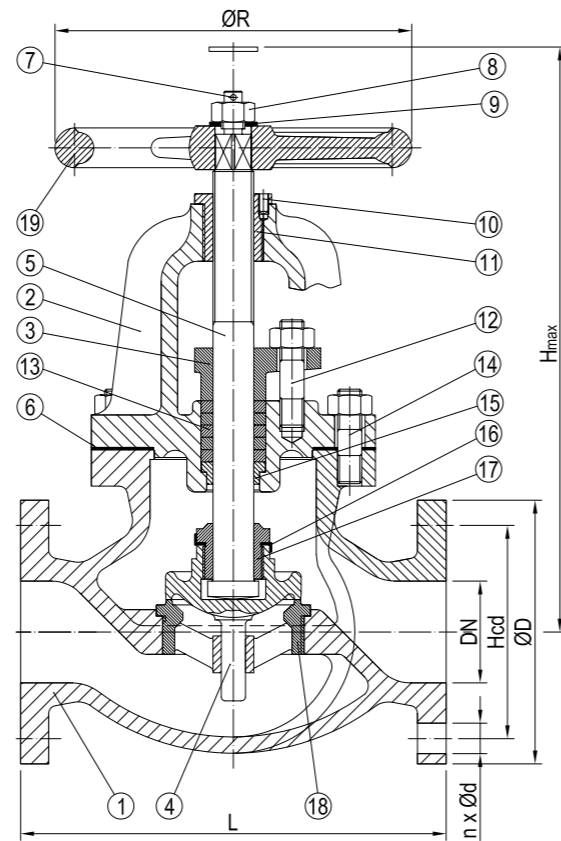

DN	n x ød	Hcd	øD	L	H _{max}	øR	Kg
50	8x19	120	155	220	285	160	19.6
65	8x19	140	175	270	310	200	28.3
80	8x23	160	200	300	340	224	40.4
100	8x23	185	225	350	385	250	56.9
125	8x25	225	270	430	455	315	89.5
150	12x25	260	305	500	510	355	123.0
200	12x25	305	350	570	630	450	188.0



GLOBE VALVE

ANGLE TYPE, FLANGED ENDS

F-7310/F-7378
JIS 16K

DESCRIPTION: Angled type, grey cast iron body, metal seated screw down stop valve with rising stem, bolted bonnet. Flat face flanged.

APPLICATION: Start/stop and throttling of: Sea water, water and oils etc.

STANDARD & DESIGN:

Design Code: JIS F7310
 Inspection Std.: JIS F7400
 End Std.: JIS B2220
 Face to Face Std.: -
 Flanges Drilled: JIS 16K(DN50-DN200)
 Pressure rating: JIS 16K(DN50-DN200)

VARIATIONS: Available with Stainless Steel (2Cr13) trim
 F-7310=Fixed Disc
 F-7378=SDNR
 Other dimensions and materials on request.

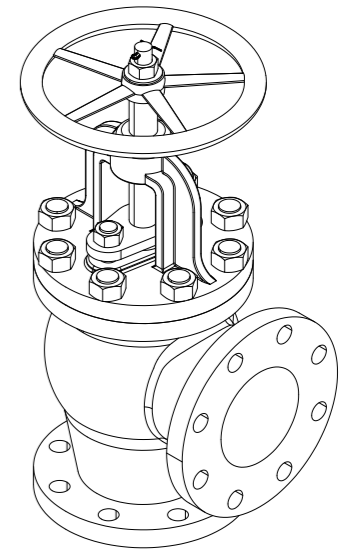

No	Part	Material	Code
1	Body	Cast Iron	HT200
2	Bonnet	Cast Iron	HT200
3	Gland	Brass	H62
4	Disc	Bronze	ZCuSn5Pb5Zn5
5	Stem	Brass	H62
6	Gasket	Graphite	-
7	Split Pin	Carbon Steel	A3
8	Nut	Carbon Steel	Q235A
9	Gasket Ring	Carbon Steel	Q235A
10	Screw	Carbon Steel	Q235A
11	Screwed Bonnet Bush	Brass	H62
12	Double Open End Bolt	Carbon Steel	Q235A
13	Packing	Graphite	-
14	Double Open End Bolt	Carbon Steel	Q235A
15	Packing Seat	Brass	H62
16	Check Washer	Brass	H62
17	Disc Nut	Brass	H62
18	Sealing Ring	Bronze	ZCuSn5Pb5Zn5
19	Handwheel	Cast Iron	HT200

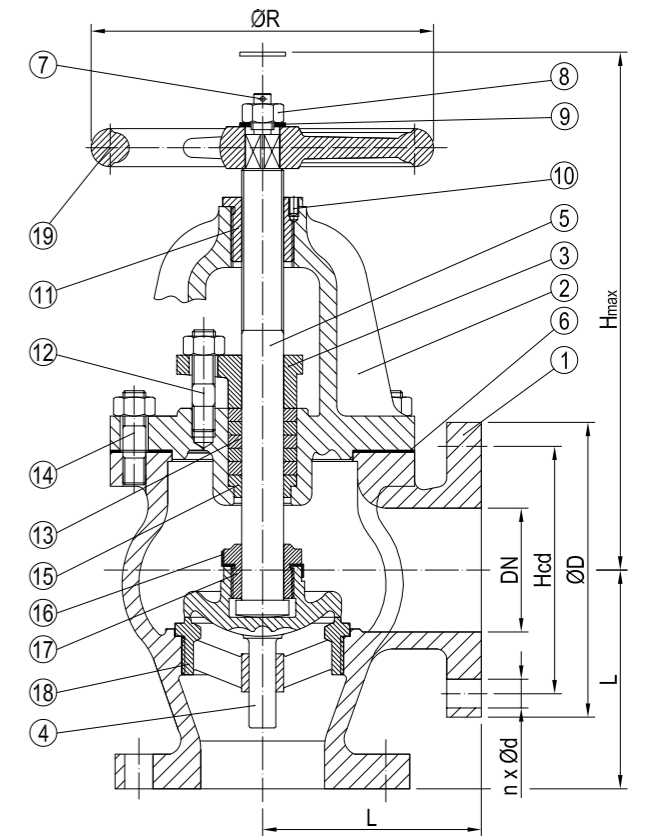

DN	n x ød	Hcd	øD	L	H _{max}	øR	Kg
50	8x19	120	155	120	255	160	18.0
65	8x19	140	175	130	270	200	25.0
80	8x23	160	200	150	295	224	35.7
100	8x23	185	225	170	330	250	49.2
125	8x25	225	270	200	390	315	76.1
150	12x25	260	305	225	435	355	103.0
200	12x25	305	350	250	540	450	155.0



GLOBE VALVE

STRAIGHT, FLANGED ENDS

F-7311
JIS 5K

DESCRIPTION: Straight type, cast steel body, metal seated screw down stop valve with rising stem, bolted bonnet. Flat face flanged.

APPLICATION: Start/stop and throttling of: Sea water (with Rg5 trim), water, steam and oils etc.

STANDARD & DESIGN:

Design Code: JIS F7311
 Inspection Std.: JIS F7400
 End Std.: JIS B2220
 Face to Face Std.: -
 Flanges Drilled: JIS 5K(DN50-DN300)
 Pressure rating: JIS 5K(DN50-DN300)

VARIATIONS: Other dimensions and materials on request. Available with Rg5 trim for sea water application.

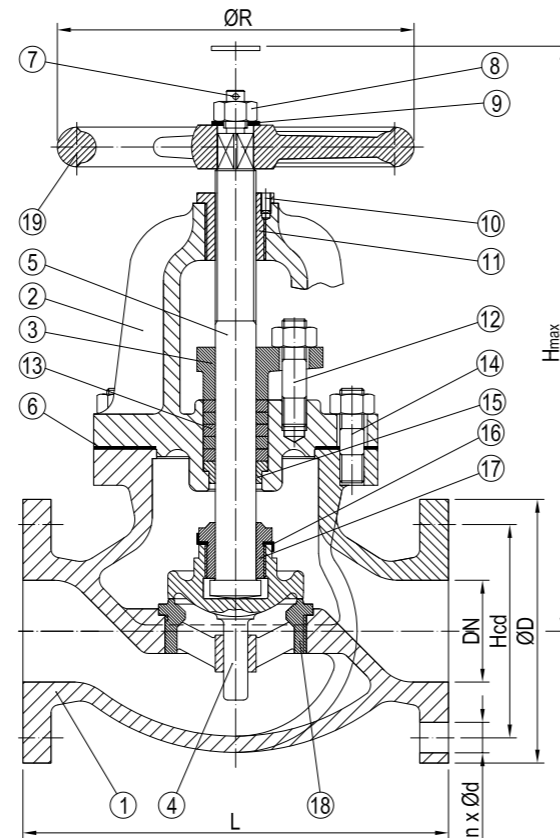
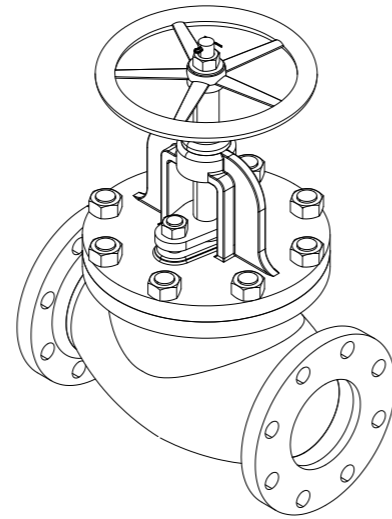

No	Part	Material	Code
1	Body	Cast Steel	ZG230-450
2	Bonnet	Cast Steel	ZG230-450
3	Gland	Stainless Steel	2Cr13
4	Disc	Stainless Steel	2Cr13
5	Stem	Stainless Steel	2Cr13
6	Gasket	Graphite	-
7	Split Pin	Carbon Steel	A3
8	Nut	Carbon Steel	Q235A
9	Gasket Ring	Carbon Steel	Q235A
10	Screw	Carbon Steel	Q235A
11	Screwed Bonnet Bush	Brass	H62
12	Double Open End Bolt	Carbon Steel	Q235A
13	Packing	Graphite	-
14	Double Open End Bolt	Carbon Steel	Q235A
15	Packing Seat	Brass	H62
16	Check Washer	Brass	H62
17	Disc Nut	Stainless Steel	2Cr13
18	Sealing Ring	Stainless Steel	2Cr13
19	Handwheel	Cast Iron	HT200

DN	n x ød	Hcd	øD	L	H _{max}	øR	Kg
50	4x15	105	130	210	270	160	14.7
65	4x15	130	155	250	300	180	21.3
80	4x19	145	180	280	310	180	27.7
100	8x19	165	200	340	360	224	40.8
125	8x19	200	235	410	390	250	57.6
150	8x19	230	265	480	445	280	80.3
200	8x23	280	320	570	530	315	139.0
250	12x23	345	385	740	650	355	230.0
300	12x23	390	430	840	740	400	309.0



GLOBE VALVE

ANGLE TYPE, FLANGED ENDS

F-7312
JIS 5K

DESCRIPTION: Angled type, cast steel body, metal seated screw down stop valve with rising stem, bolted bonnet. Flat face flanged.

APPLICATION: Start/stop and throttling of: Sea water (with Rg5 trim), water, steam and oils etc.

STANDARD & DESIGN:

Design Code: JIS F7312
 Inspection Std.: JIS F7400
 End Std.: JIS B2220
 Face to Face Std.: -
 Flanges Drilled: JIS 5K(DN50-DN300)
 Pressure rating: JIS 5K(DN50-DN300)

VARIATIONS: Other dimensions and materials on request. Available with Rg5 trim for sea water application.

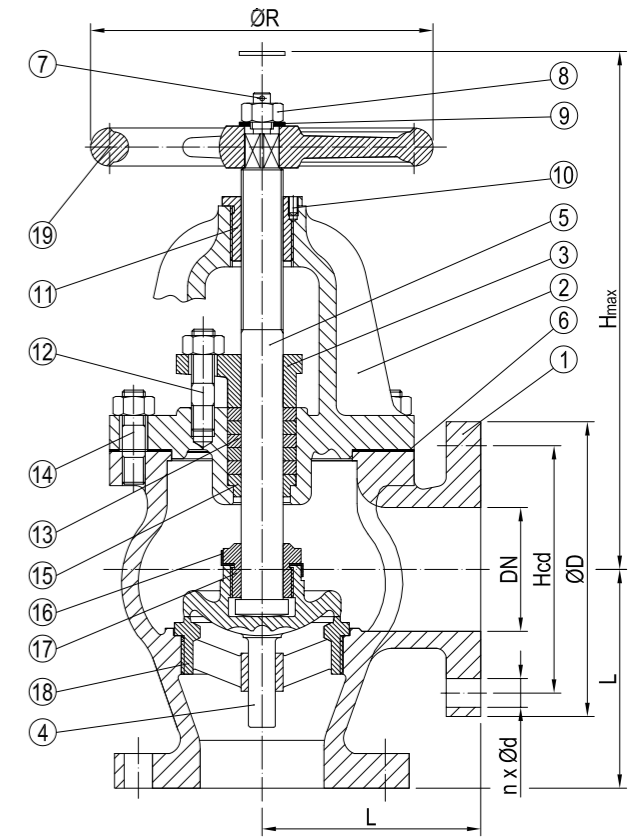
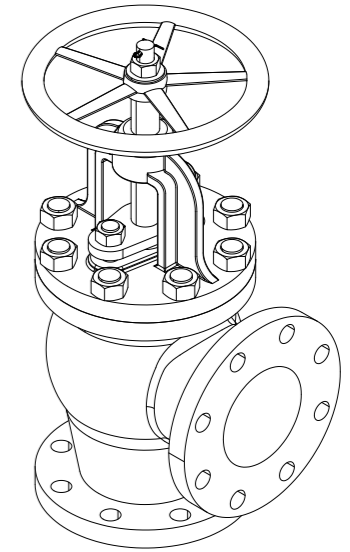

No	Part	Material	Code
1	Body	Cast Steel	ZG230-450
2	Bonnet	Cast Steel	ZG230-450
3	Gland	Stainless Steel	2Cr13
4	Disc	Stainless Steel	2Cr13
5	Stem	Stainless Steel	2Cr13
6	Gasket	Graphite	-
7	Split Pin	Carbon Steel	A3
8	Nut	Carbon Steel	Q235A
9	Gasket Ring	Carbon Steel	Q235A
10	Screw	Carbon Steel	Q235A
11	Screwed Bonnet Bush	Brass	H62
12	Double Open End Bolt	Carbon Steel	Q235A
13	Packing	Graphite	-
14	Double Open End Bolt	Carbon Steel	Q235A
15	Packing Seat	Brass	H62
16	Check Washer	Brass	H62
17	Disc Nut	Brass	H62
18	Sealing Ring	Stainless Steel	2Cr13
19	Handwheel	Cast Iron	HT200

DN	n x ød	Hcd	øD	L	H _{max}	øR	Kg
50	4x15	105	130	100	240	160	12.9
65	4x15	130	155	115	255	180	18.2
80	4x19	145	180	130	265	180	23.4
100	8x19	165	200	150	310	224	33.7
125	8x19	200	235	170	330	250	46.2
150	8x19	230	265	190	380	280	63.4
200	8x23	280	320	220	450	315	105.0
250	12x23	345	385	275	645	355	178.0
300	12x23	390	430	310	750	400	275.0



GLOBE VALVE

STRAIGHT, FLANGED ENDS

F-7313/F-7473
JIS 20K

DESCRIPTION: Straight type, cast steel body, metal seated screw down stop valve with rising stem, bolted bonnet. Flat face flanged.

APPLICATION: Start/stop and throttling of: Sea water (with Rg5 trim), water, steam and oils etc.

STANDARD & DESIGN:

Design Code: JIS F7313
 Inspection Std.: JIS F7400
 End Std.: JIS B2220
 Face to Face Std.: -
 Flanges Drilled: JIS 20K(DN32-DN250)
 Pressure rating: JIS 20K(DN32-DN250)

VARIATIONS: F-7313=Fixed Disc
 F-7473=SDNR

Other dimensions and materials on request.
 Available with Rg5 trim for sea water application.

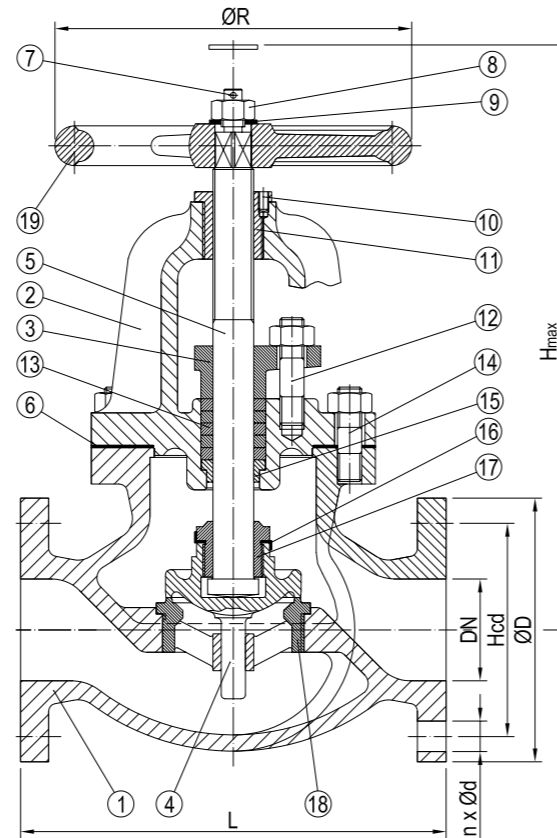
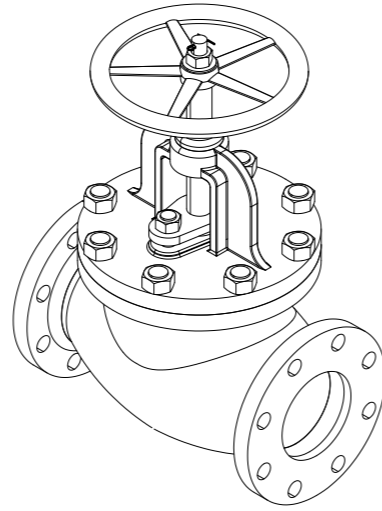

No	Part	Material	Code
1	Body	Cast Steel	ZG230-450
2	Bonnet	Cast Steel	ZG230-450
3	Gland	Stainless Steel	2Cr13
4	Disc	Stainless Steel	2Cr13
5	Stem	Stainless Steel	2Cr13
6	Gasket	Graphite	-
7	Split Pin	Carbon Steel	A3
8	Nut	Carbon Steel	Q235A
9	Gasket Ring	Carbon Steel	Q235A
10	Screw	Carbon Steel	Q235A
11	Screwed Bonnet Bush	Brass	H62
12	Double Open End Bolt	Carbon Steel	Q235A
13	Packing	Graphite	-
14	Double Open End Bolt	Carbon Steel	Q235A
15	Packing Seat	Brass	H62
16	Check Washer	Brass	H62
17	Disc Nut	Stainless Steel	2Cr13
18	Sealing Ring	Stainless Steel	2Cr13
19	Handwheel	Cast Iron	HT200

DN	n x ød	Hcd	øD	L	H _{max}	øR	Kg
32	4x19	100	135	190	270	160	14.4
40	4x19	105	140	200	290	160	16.0
50	8x19	120	155	230	305	200	21.6
65	8x19	140	175	270	345	224	30.4
80	8x23	160	200	300	385	250	43.5
100	8x23	185	225	350	440	280	62.3
125	8x25	225	270	430	500	315	95.7
150	12x25	260	305	500	550	355	133.3
200	12x25	305	350	560	630	450	-
250	12x27	380	430	660	725	560	-



GLOBE VALVE

ANGLE TYPE, FLANGED ENDS

F-7314/F-7474
JIS 20K

DESCRIPTION: Angled type, cast steel body, metal seated screw down stop valve with rising stem, bolted bonnet. Flat face flanged.

APPLICATION: Start/stop and throttling of: Sea water (with Rg5 trim), water, steam and oils etc.

STANDARD & DESIGN:

Design Code: JIS F7314
 Inspection Std.: JIS F7400
 End Std.: JIS B2220
 Face to Face Std.: -
 Flanges Drilled: JIS 20K(DN32-DN250)
 Pressure rating: JIS 20K(DN32-DN250)

VARIATIONS: F-7314=Fixed Disc
 F-7474=SDNR

Other dimensions and materials on request.
 Available with Rg5 trim for sea water application.

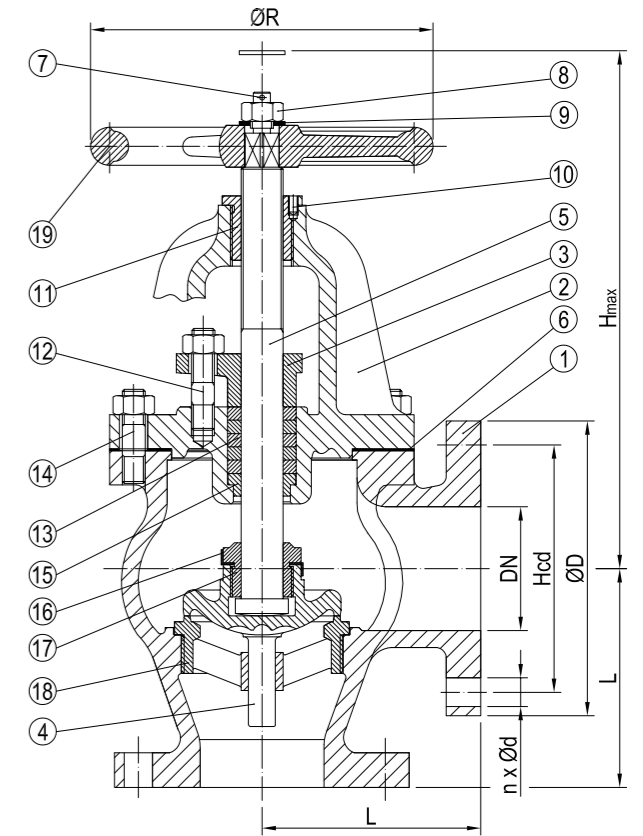
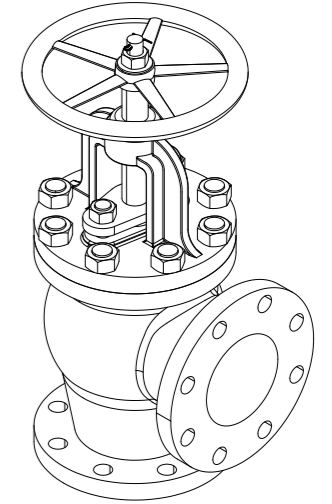

No	Part	Material	Code
1	Body	Cast Steel	ZG230-450
2	Bonnet	Cast Steel	ZG230-450
3	Gland	Stainless Steel	2Cr13
4	Disc	Stainless Steel	2Cr13
5	Stem	Stainless Steel	2Cr13
6	Gasket	Graphite	-
7	Split Pin	Carbon Steel	A3
8	Nut	Carbon Steel	Q235A
9	Gasket Ring	Carbon Steel	Q235A
10	Screw	Carbon Steel	Q235A
11	Screwed Bonnet Bush	Brass	H62
12	Double Open End Bolt	Carbon Steel	Q235A
13	Packing	Graphite	-
14	Double Open End Bolt	Carbon Steel	Q235A
15	Packing Seat	Brass	H62
16	Check Washer	Brass	H62
17	Disc Nut	Stainless Steel	2Cr13
18	Sealing Ring	Stainless Steel	2Cr13
19	Handwheel	Cast Iron	HT200

DN	n x ød	Hcd	øD	L	H _{max}	øR	Kg
32	4x19	100	135	100	240	160	13.0
40	4x19	105	140	110	255	160	15.2
50	8x19	120	155	125	270	200	20.0
65	8x19	140	175	135	295	224	26.9
80	8x23	160	200	150	325	250	38.9
100	8x23	185	225	170	365	280	54.4
125	8x25	225	270	200	415	315	80.7
150	12x25	260	305	225	460	355	112.3
200	12x25	305	350	280	520	450	-
250	12x27	380	430	310	595	560	-



GLOBE VALVE

STRAIGHT, FLANGED ENDS

F-7319/F-7471
JIS 10K

DESCRIPTION: Straight type, cast steel body, metal seated screw down stop valve with rising stem, bolted bonnet. Flat face flanged.

APPLICATION: Start/stop and throttling of: Sea water (with Rg5 trim), water, steam and oils etc.

STANDARD & DESIGN:

Design Code: JIS F7319
 Inspection Std.: JIS F7400
 End Std.: JIS B2220
 Face to Face Std.: -
 Flanges Drilled: JIS 10K(DN50-DN300)
 Pressure rating: JIS 10K(DN50-DN300)

VARIATIONS: F-7319=Fixed Disc
 F-7471=SDNR

Other dimensions and materials on request.
 Available with Rg5 trim for sea water application.

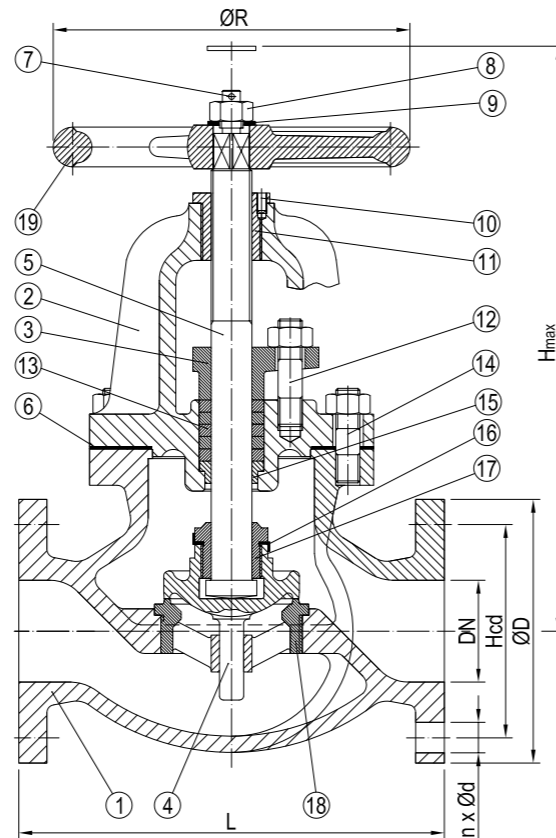
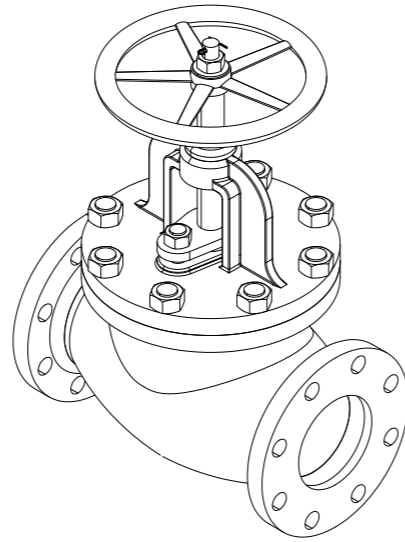

No	Part	Material	Code
1	Body	Cast Steel	ZG230-450
2	Bonnet	Cast Steel	ZG230-450
3	Gland	Stainless Steel	2Cr13
4	Disc	Stainless Steel	2Cr13
5	Stem	Stainless Steel	2Cr13
6	Gasket	Graphite	-
7	Split Pin	Carbon Steel	A3
8	Nut	Carbon Steel	Q235A
9	Gasket Ring	Carbon Steel	Q235A
10	Screw	Carbon Steel	Q235A
11	Screwed Bonnet Bush	Brass	H62
12	Double Open End Bolt	Carbon Steel	Q235A
13	Packing	Graphite	-
14	Double Open End Bolt	Carbon Steel	Q235A
15	Packing Seat	Brass	H62
16	Check Washer	Brass	H62
17	Disc Nut	Stainless Steel	2Cr13
18	Sealing Ring	Stainless Steel	2Cr13
19	Handwheel	Cast Iron	HT200

DN	n x ød	Hcd	øD	L	H _{max}	øR	Kg
50	4x19	120	155	220	270	160	17.9
65	4x19	140	175	270	300	200	26.0
80	8x19	150	185	300	310	200	29.8
100	8x19	175	210	350	355	250	44.7
125	8x23	210	250	420	415	280	70.3
150	8x23	240	280	490	470	315	96.4
200	12x23	290	330	570	565	355	159.0
250	12x25	355	400	740	645	400	257.0
300	12x25	400	445	840	735	450	370.0



GLOBE VALVE

ANGLE TYPE, FLANGED ENDS

F-7320/F-7472
JIS 10K

DESCRIPTION: Angled type, cast steel body, metal seated screw down stop valve with rising stem, bolted bonnet. Flat face flanged.

APPLICATION: Start/stop and throttling of: Sea water (with Rg5 trim), water, steam and oils etc.

STANDARD & DESIGN:

Design Code: JIS F7320
 Inspection Std.: JIS F7400
 End Std.: JIS B2220
 Face to Face Std.: -
 Flanges Drilled: JIS 10K(DN50-DN300)
 Pressure rating: JIS 10K(DN50-DN300)

VARIATIONS: F-7320=Fixed Disc
 F-7472=SDNR

Other dimensions and materials on request.
 Available with Rg5 trim for sea water application.

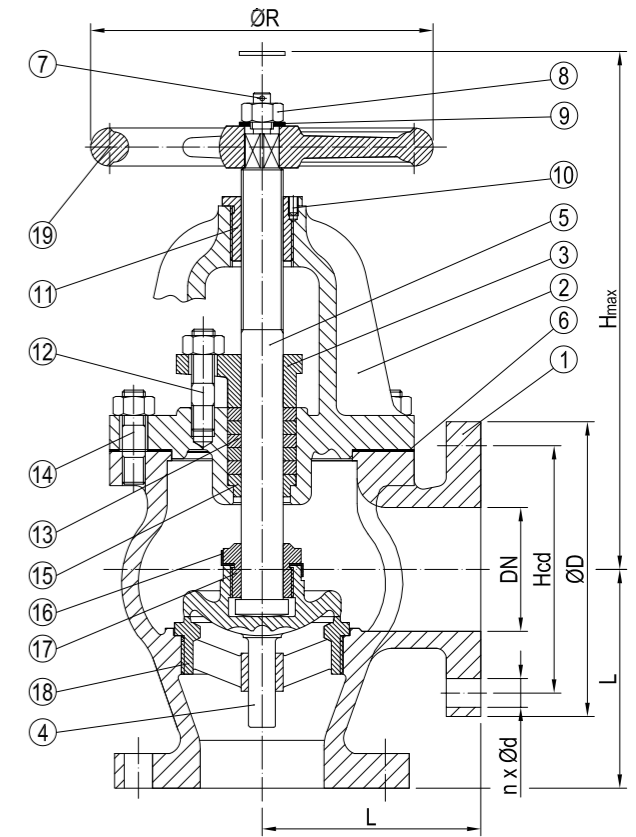
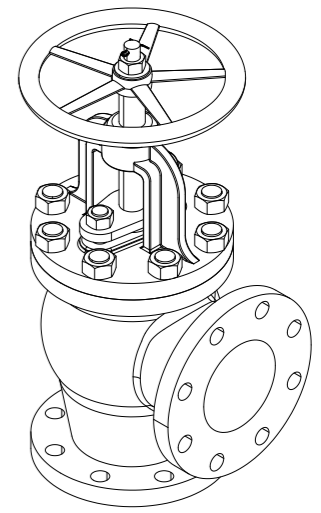

No	Part	Material	Code
1	Body	Cast Steel	ZG230-450
2	Bonnet	Cast Steel	ZG230-450
3	Gland	Stainless Steel	2Cr13
4	Disc	Stainless Steel	2Cr13
5	Stem	Stainless Steel	2Cr13
6	Gasket	Graphite	-
7	Split Pin	Carbon Steel	A3
8	Nut	Carbon Steel	Q235A
9	Gasket Ring	Carbon Steel	Q235A
10	Screw	Carbon Steel	Q235A
11	Screwed Bonnet Bush	Brass	H62
12	Double Open End Bolt	Carbon Steel	Q235A
13	Packing	Graphite	-
14	Double Open End Bolt	Carbon Steel	Q235A
15	Packing Seat	Brass	H62
16	Check Washer	Brass	H62
17	Disc Nut	Stainless Steel	2Cr13
18	Sealing Ring	Stainless Steel	2Cr13
19	Handwheel	Cast Iron	HT200

DN	n x ød	Hcd	øD	L	H _{max}	øR	Kg
50	4x19	120	155	120	240	160	16.3
65	4x19	140	175	130	260	200	23.0
80	8x19	150	185	140	265	200	25.3
100	8x19	175	210	160	300	250	37.0
125	8x23	210	250	180	350	280	57.1
150	8x23	240	280	205	400	315	77.2
200	12x23	290	330	230	480	355	116.0
250	12x25	355	400	290	535	400	188.0
300	16x25	400	445	320	610	450	256.0



STORM FLAP VALVES & CHECK VALVES

Used to avoid flow in both directions. Often placed in connection with pumps.
Available with threaded, flanged or weld end connections.
Also available in wafer version to be mounted between flanges.
Metal to metal sealing or soft sealing.



STORM VALVE

STRAIGHT, FLANGED ENDS

F-3060
JIS 5K/JIS 10K

DESCRIPTION: Straight type closable check valve. Cast steel body. Soft sealing disc. Flat face flanged.

APPLICATION: Ship side valve for discharge of various sanitary systems. Preventing sea water from entering the piping system. Manually closable at e.g. dry docking.

STANDARD & DESIGN:

Design Code: JIS F3060
 Inspection Std.: JIS F7400
 End Std.: JIS B2220
 Face to Face Std.: -
 Flanges drilled: JIS 5K(DN50-DN150)
 JIS 10K(DN50-DN150)
 Pressure rating: JIS 5K(DN50-DN150)
 JIS 10K(DN50-DN150)

VARIATIONS: Other materials and dimensions on request. Flange drilling 10K

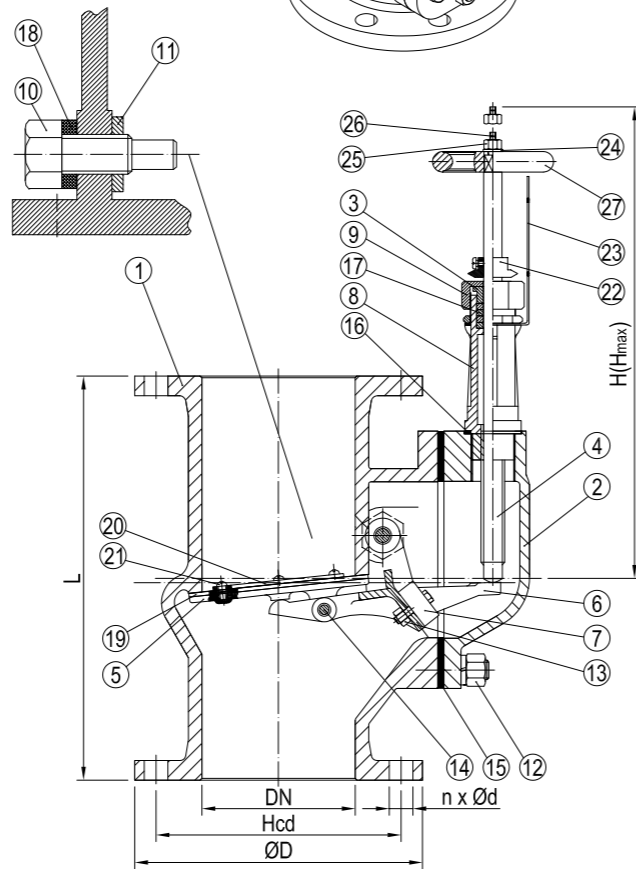
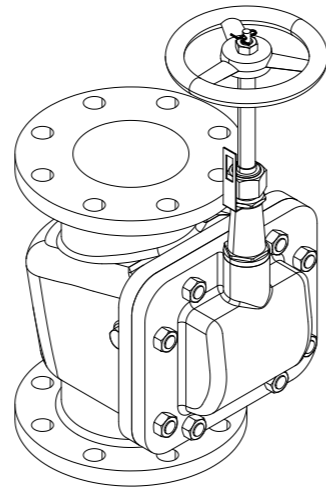

No	Part	Material	Code
1	Body	Cast Steel	ZG230-450
2	Cover	Cast Steel	ZG230-450
3	Gland	Brass	H62
4	Spindle	Stainless Steel	2Cr13
5	Valve Plate	Brass	H62
6	Closing Arm for Valve Plate	Brass	H62
7	Counterweight	Lead	Pb
8	Spindle Box	Brass	H62
9	Packing Gland Nut	Brass	H62
10	Valve Axle	Stainless Steel	2Cr13
11	Washer	Brass	H62
12	Nut	Carbon Steel	Q235A
13	Nut	Carbon Steel	Q235A
14	Nut	Brass	H62
15	Gasket	Graphite	-
16	Gasket	Graphite	-
17	Packing	Graphite	-
18	Gasket	Graphite	-
19	Gasket	EPDM	-
20	Set Plate for Gasket	Stainless Steel	304
21	Set Screw for Gasket	Carbon Steel	Q235A
22	Staff	Brass	H62
23	Staff	Brass	H62
24	Cushion	Carbon Steel	Q235A
25	Nut	Carbon Steel	Q235A
26	Split Pin	Carbon Steel	A3
27	Handwheel	Cast Iron	FC 200

5K

DN	n x ød	Hcd	øD	L	H	H _{max}	Kg
50	4x15	105	130	210	290	328	12.3
65	4x15	130	155	240	290	335	17.8
80	4x19	145	180	260	290	335	23.3
100	8x19	165	200	280	290	340	30.6
125	8x19	200	235	330	290	340	50.0
150	8x19	230	265	360	290	345	67.0

10K

DN	n x ød	Hcd	øD	L	H	H _{max}	Kg
50	4x19	120	155	210	290	328	13.4
65	4x19	140	175	240	290	335	18.7
80	8x19	150	185	260	290	335	23.3
100	8x19	175	210	280	290	340	31.9
125	8x23	210	250	330	290	340	-
150	8x23	240	280	360	290	345	-



STORM VALVE

ANGLE TYPE, FLANGED ENDS

F-3061
JIS 5K/JIS 10K

DESCRIPTION: Angled type closable check valve. Cast steel body. Soft sealing disc. Flat face flanged.

APPLICATION: Ship side valve for discharge of various sanitary systems. Preventing sea water from entering the piping system. Manually closable at e.g. dry docking.

STANDARD & DESIGN:

Design Code: JIS F3060R
 Inspection Std.: JIS F7400
 End Std.: JIS B2220
 Face to Face Std.: -
 Flanges drilled: JIS 5K(DN50-DN150)
 JIS 10K(DN50-DN150)
 Pressure rating: JIS 5K(DN50-DN150)
 JIS 10K(DN50-DN150)

VARIATIONS: Other materials and dimensions on request. Flange drilling 10K

No	Part	Material	Code
1	Body	Cast Steel	ZG230-450
2	Cover	Cast Steel	ZG230-450
3	Gland	Brass	H62
4	Spindle	Stainless Steel	2Cr13
5	Valve Plate	Brass	H62
6	Closing Arm for Valve Plate	Brass	H62
7	Counterweight	Lead	Pb
8	Spindle Box	Brass	H62
9	Packing Gland Nut	Brass	H62
10	Valve Axle	Stainless Steel	2Cr13
11	Washer	Graphite	-
12	Nut	Carbon Steel	Q235A
13	Nut	Carbon Steel	Q235A
14	Nut	Brass	H62
15	Gasket	Graphite	-
16	Gasket	Graphite	-
17	Packing	Graphite	-
18	Gasket	Graphite	-
19	Gasket	EPDM	-
20	Set Plate for Gasket	Stainless Steel	304
21	Set Screw for Gasket	Carbon Steel	Q235A
22	Staff	Brass	H62
23	Staff	Brass	H62
24	Cushion	Carbon Steel	Q235A
25	Nut	Carbon Steel	Q235A
26	Split Pin	Carbon Steel	A3
27	Handwheel	Cast Iron	FC 200

5K

DN	n x ød	Hcd	øD	L1	L2	L3	H _{max}	Kg
50	4x15	105	130	170	90	135	187	12.4
65	4x15	130	155	200	110	145	175	16.5
80	4x19	145	180	220	120	155	180	22.3
100	8x19	165	200	250	130	175	175	28.9
125	8x19	200	235	270	150	195	192	50.0
150	8x19	230	265	310	165	215	187	52.7

10K

DN	n x ød	Hcd	øD	L1	L2	L3	H _{max}	Kg
50	4x19	120	155	170	90	135	187	12.9
65	4x19	140	175	200	110	145	175	17.8
80	8x19	150	185	220	120	155	180	22.4
100	8x19	175	210	250	130	175	175	29.8
125	8x23	210	250	270	150	195	192	-
150	8x23	240	280	310	165	215	187	-

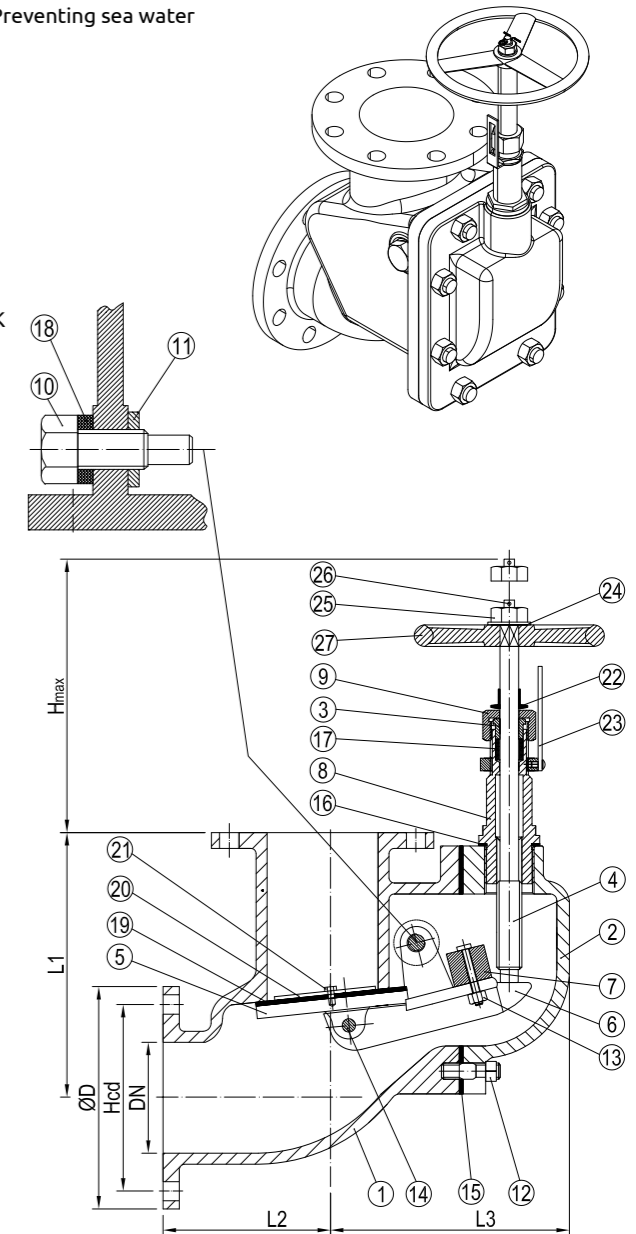



GATE VALVES

For shut off purposes. Can be delivered with visual position indicator.
Available with threaded, flanged or weld end connections.
Metal to metal sealing or soft sealing.
Available with different types of actuators.



GATE VALVE

FLANGED ENDS

F-7363
JIS 5K

DESCRIPTION: Grey cast iron body gate valve, Rg5 seat rings. Non rising stem, open/close indicator. Bolted bonnet. Flat face flanged.

APPLICATION: Start/stop flow with minimized pressure drop for air/gases, sea water, water, oils etc.

STANDARD & DESIGN:

Design Code: JIS F7363
 Inspection Std.: JIS F7400
 End Std.: JIS B2220
 Face to Face Std.: -
 Flanges drilled: JIS 5K(DN50-DN400)
 Pressure rating: JIS 5K(DN50-DN400)

VARIATIONS: Available with stainless steel(2Cr13) trim.
 Other dimensions and materials on request.

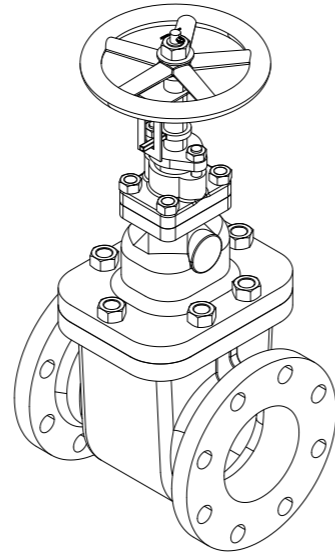

No	Part	Material	Code
1	Body	Cast Iron	HT 200
2	Bonnet	Cast Iron	HT 200
3	Gland	Brass	H62
4	Stem	Brass	H62
5	Sealing Ring	Bronze	ZCuSn5Pb5Zn5
6	Wedge	Cast Iron	HT 200
7	Square Nut	Brass	H62
8	Gasket	Graphite	-
9	Thrust Bush	Brass	H62
10	Thrust Pad	Brass	H62
11	Gasket	Graphite	-
12	Packing Box	Cast Iron	HT 200
13	Packing	Graphite	-
14	Double Open End Bolt	Carbon Steel	Q235A
15	Nut	Carbon Steel	Q235A
16	Staff	Brass	H62
17	Cushion	Carbon Steel	Q235A
18	Split Pin	Carbon Steel	A3
19	Nut	Carbon Steel	Q235A
20	Scale	Brass	H62
21	Screw	Carbon Steel	Q235A
22	Nut	Carbon Steel	Q235A
23	Double Open End Bolt	Carbon Steel	Q235A
24	Nut	Carbon Steel	Q235A
25	Double Open End Bolt	Carbon Steel	Q235A
26	Sealing Ring	Bronze	ZCuSn5Pb5Zn5
27	Gasket	Graphite	-
28	Plug	Brass	H62
29	Handwheel	Cast Iron	HT 200

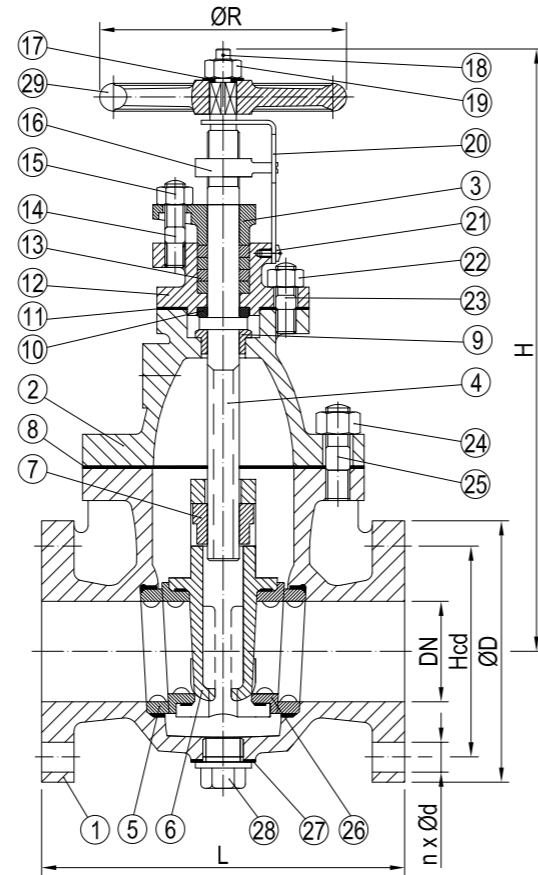

DN	n x ød	Hcd	øD	L	H	øR	Kg
50	4x15	105	130	180	285	125	13.5
65	4x15	130	155	190	330	140	19.0
80	4x19	145	180	200	380	160	24.2
100	8x19	165	200	230	430	180	35.3
125	8x19	200	235	250	495	200	48.1
150	8x19	230	265	270	560	224	65.3
200	8x23	280	320	290	680	280	103.0
250	12x23	345	385	330	800	355	164.0
300	12x23	390	430	370	920	400	236.0
350	12x25	435	480	410	1000	450	-
400	16x25	495	540	470	1100	500	-



GATE VALVE

FLANGED ENDS

F-7364
JIS 10K

DESCRIPTION: Grey cast iron body gate valve, Rg5 seat rings. Non rising stem, open/close indicator. Bolted bonnet. Flat face flanged.

APPLICATION: Start/stop flow with minimized pressure drop for air/gases, sea water, water, oils etc.

STANDARD & DESIGN:

Design Code: JIS F7364
 Inspection Std.: JIS F7400
 End Std.: JIS B2220
 Face to Face Std.: -
 Flanges drilled: JIS 10K(DN50-DN400)
 Pressure rating: JIS 10K(DN50-DN400)

VARIATIONS: Available with stainless steel(2Cr13) trim.
 Other dimensions and materials on request.

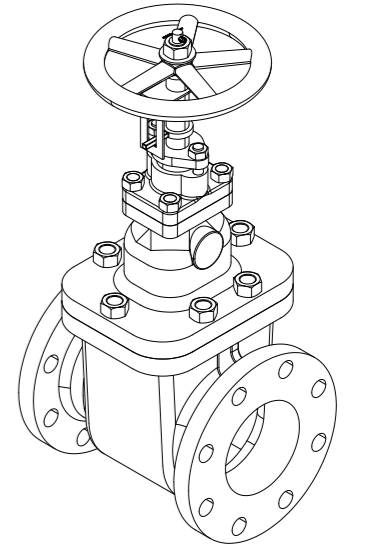

No	Part	Material	Code
1	Body	Cast Iron	HT 200
2	Bonnet	Cast Iron	HT 200
3	Gland	Brass	H62
4	Stem	Brass	H62
5	Sealing Ring	Bronze	ZCuSn5Pb5Zn5
6	Wedge	Cast Iron	HT 200
7	Square Nut	Brass	H62
8	Gasket	Graphite	-
9	Thrust Bush	Brass	H62
10	Thrust Pad	Brass	H62
11	Gasket	Graphite	-
12	Packing Box	Cast Iron	HT 200
13	Packing	Graphite	-
14	Double Open End Bolt	Carbon Steel	Q235A
15	Nut	Carbon Steel	Q235A
16	Staff	Brass	H62
17	Cushion	Carbon Steel	Q235A
18	Split Pin	Carbon Steel	A3
19	Nut	Carbon Steel	Q235A
20	Scale	Brass	H62
21	Screw	Carbon Steel	Q235A
22	Nut	Carbon Steel	Q235A
23	Double Open End Bolt	Carbon Steel	Q235A
24	Nut	Carbon Steel	Q235A
25	Double Open End Bolt	Carbon Steel	Q235A
26	Sealing Ring	Bronze	ZCuSn5Pb5Zn5
27	Gasket	Graphite	-
28	Plug	Brass	H62
29	Handwheel	Cast Iron	HT 200

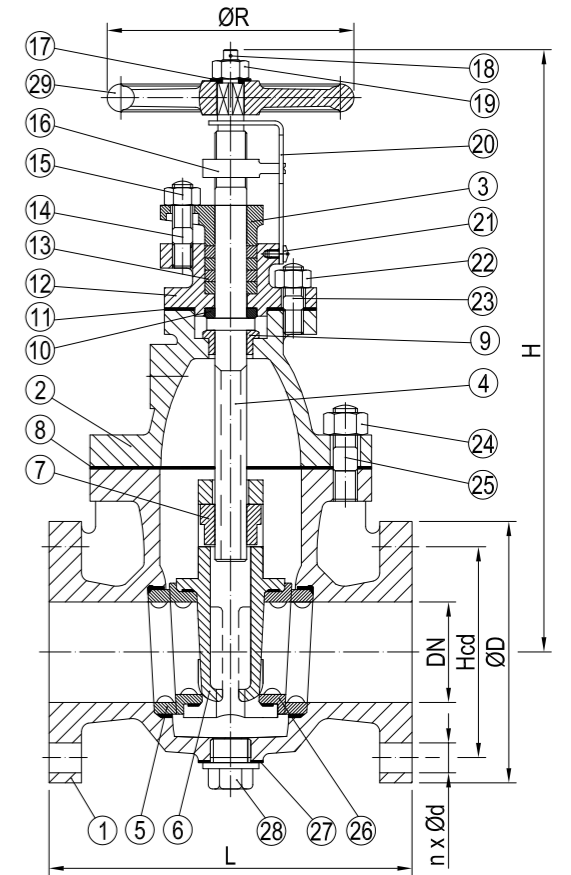

DN	n x ød	Hcd	øD	L	H	øR	Kg
50	4x19	120	155	200	300	140	19.4
65	4x19	140	175	220	350	160	27.6
80	8x19	150	185	230	400	180	33.0
100	8x19	175	210	250	450	200	45.8
125	8x23	210	250	270	520	224	65.9
150	8x23	240	280	290	580	250	86.0
200	12x23	290	330	320	700	315	136.0
250	12x25	355	400	380	840	400	230.0
300	16x25	400	445	440	960	450	331.0
350	16x25	445	490	500	1050	500	-
400	16x27	510	560	590	1150	560	-



GATE VALVE

FLANGED ENDS

F-7366
JIS 10K

DESCRIPTION: Cast steel body gate valve with stainless steel trim.
Non rising stem, open/close indicator. Bolted bonnet. Flat face flanged.

APPLICATION: Start/stop flow with minimized pressure drop for air/gases, sea water (with Rg5 trim), water, oils and aggressive/abrasive media etc.

STANDARD & DESIGN:

Design Code: JIS F7366
 Inspection Std.: JIS F7400
 End Std.: JIS B2220
 Face to Face Std.: -
 Flanges drilled: JIS 10K(DN50-DN400)
 Pressure rating: JIS 10K(DN50-DN400)

VARIATIONS: Other dimensions and materials on request.
Available with Rg5 trim.

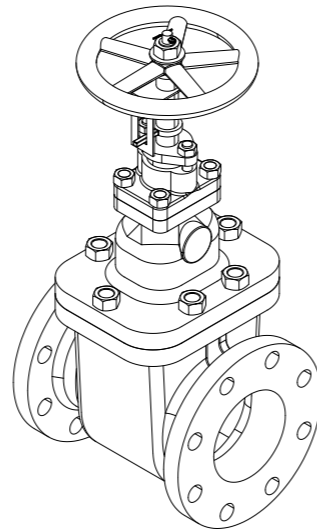

No	Part	Material	Code
1	Body	Cast Steel	ZG230-450
2	Bonnet	Cast Steel	ZG230-450
3	Gland	Stainless Steel	2Cr13
4	Stem	Stainless Steel	2Cr13
5	Sealing Ring	Stainless Steel	2Cr13
6	Wedge	Cast Steel	ZG230-450
7	Square Nut	Brass	H62
8	Gasket	Graphite	-
9	Thrust Bush	Brass	H62
10	Thrust Pad	Brass	H62
11	Gasket	Graphite	-
12	Packing Box	Cast Steel	ZG230-450
13	Packing	Graphite	-
14	Double Open End Bolt	Carbon Steel	Q235A
15	Nut	Carbon Steel	Q235A
16	Staff	Brass	H62
17	Cushion	Carbon Steel	Q235A
18	Split Pin	Carbon Steel	A3
19	Nut	Carbon Steel	Q235A
20	Scale	Brass	H62
21	Screw	Carbon Steel	Q235A
22	Nut	Carbon Steel	Q235A
23	Double Open End Bolt	Carbon Steel	Q235A
24	Nut	Carbon Steel	Q235A
25	Double Open End Bolt	Carbon Steel	Q235A
26	Sealing Ring	Stainless Steel	2Cr13
27	Gasket	Graphite	-
28	Plug	Brass	H62
29	Handwheel	Cast Iron	HT 200

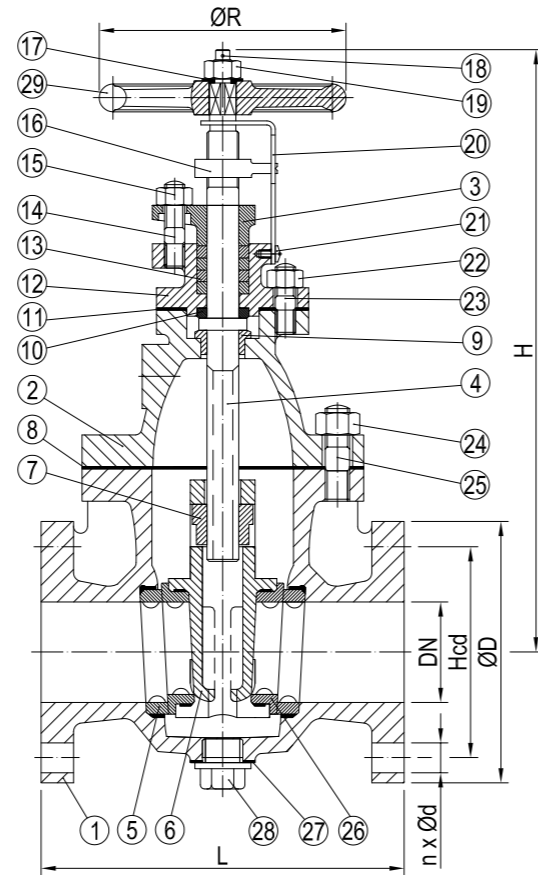

DN	n x ød	Hcd	øD	L	H	øR	Kg
50	4x19	120	155	200	300	140	17.1
65	4x19	140	175	220	350	160	26.5
80	8x19	150	185	230	400	180	31.5
100	8x19	175	210	250	450	200	44.9
125	8x23	210	250	270	520	224	63.2
150	8x23	240	280	290	580	250	82.3
200	12x23	290	330	310	700	315	130.0
250	12x25	355	400	340	840	400	203.0
300	16x25	400	445	380	960	450	291.0
350	16x25	445	490	420	1050	500	-
400	16x27	510	560	480	1150	560	-



GATE VALVE

FLANGED ENDS

F-7367
JIS 5K

DESCRIPTION: Rg5 body gate valve, Rg5 wedge. Rising stem, screwed bonnet. Flat face flanged.

APPLICATION: Start/stop flow with minimized pressure drop for air/gases, sea water, water, oils etc.

STANDARD & DESIGN:

Design Code: JIS F7367
 Inspection Std.: JIS F7400
 End Std.: JIS B2240
 Face to Face Std.: -
 Flanges drilled: JIS 5K(DN15-DN40)
 Pressure rating: JIS 5K(DN15-DN40)

VARIATIONS: Other dimensions and materials on request.

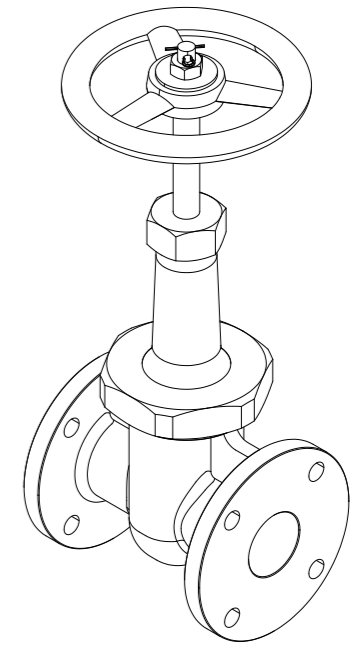

No	Part	Material	Code
1	Body	Bronze	BC6
2	Bonnet	Bronze	BC6
3	Gland	Brass	C3771 BE
4	Wedge	Bronze	BC6
5	Stem	Brass	C3771 BE
6	Union Nut	Bronze	BC6
7	Gland Nut	Brass	C3771 BE
8	Hexagonal Nut	Stainless Steel	SUS 304
9	Split Pin	Brass	C2600 W
10	Packing	Graphite	-
11	Name Plate	Aluminium	Al
12	Handwheel	Cast Iron	FC 200

DN	n x ød	Hcd	øD	L	H _{max}	øR	Kg
15	4x12	60	80	90	175	80	2.3
20	4x12	65	85	100	200	80	3.0
25	4x12	75	95	110	220	100	4.1
32	4x15	90	115	130	250	100	5.8
40	4x15	95	120	140	290	125	7.8

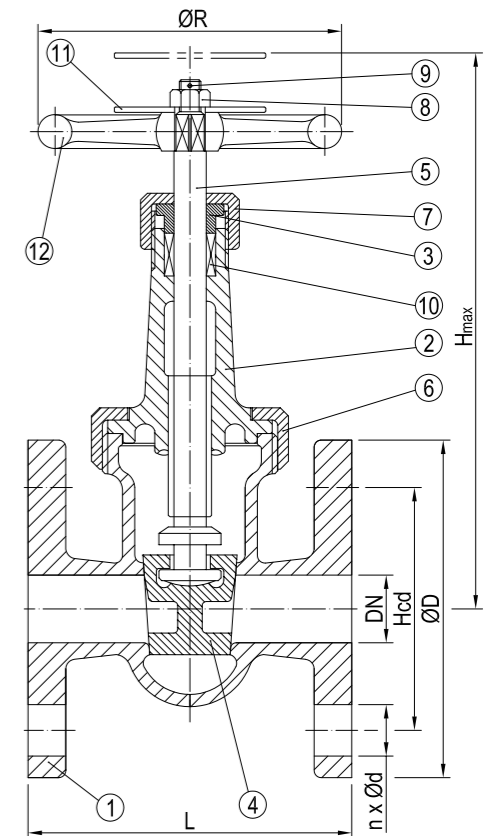



GATE VALVE

FLANGED ENDS

F-7368
JIS 10K

DESCRIPTION: Rg5 body gate valve, Rg5 wedge. Rising stem, screwed bonnet. Flat face flanged.

APPLICATION: Start/stop flow with minimized pressure drop for air/gases, sea water, water, oils etc.

STANDARD & DESIGN:

Design Code: JIS F7368
 Inspection Std.: JIS F7400
 End Std.: JIS B2240
 Face to Face Std.: -
 Flanges drilled: JIS 10K(DN15-DN40)
 Pressure rating: JIS 10K(DN15-DN40)

VARIATIONS: Other dimensions and materials on request.

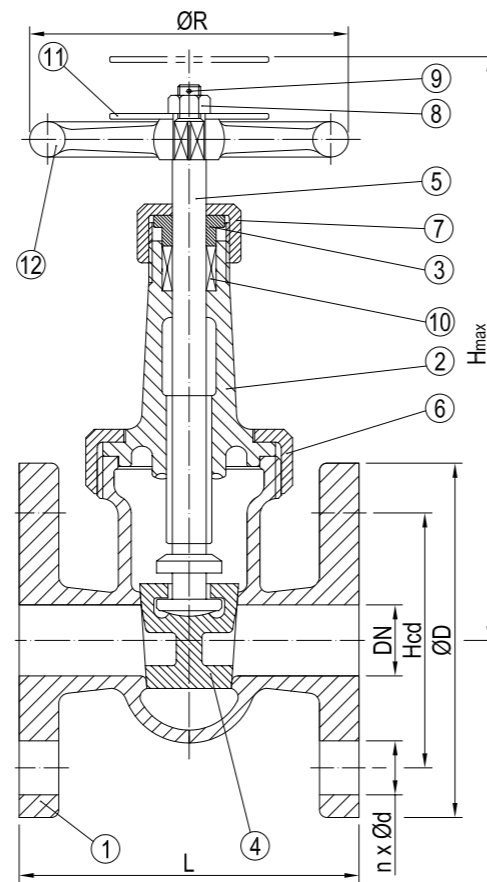
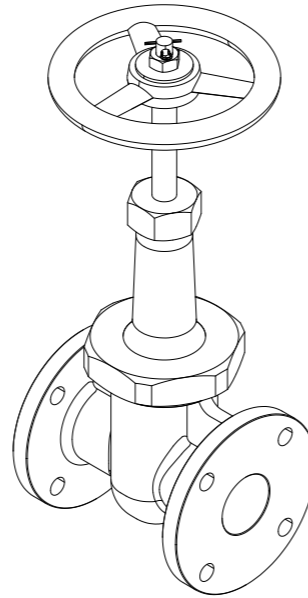

No	Part	Material	Code
1	Body	Bronze	BC6
2	Bonnet	Bronze	BC6
3	Gland	Brass	C3771 BE
4	Wedge	Bronze	BC6
5	Stem	Brass	C3771 BE
6	Union Nut	Bronze	BC6
7	Gland Nut	Brass	C3771 BE
8	Hexagonal Nut	Stainless Steel	SUS 304
9	Split Pin	Brass	C2600 W
10	Packing	Graphite	-
11	Name Plate	Aluminium	Al
12	Handwheel	Cast Iron	FC 200

DN	n x ød	Hcd	øD	L	H _{max}	øR	Kg
15	4x15	70	95	100	175	80	3.0
20	4x15	75	100	110	200	80	3.9
25	4x19	90	125	120	220	100	5.8
32	4x19	100	135	140	250	100	7.5
40	4x19	105	140	150	290	125	9.7



BUTTERFLY VALVES

For shut off or regulating purposes. Centric type or double-eccentric type suitable for high demands. Available as wafer type to be mounted between flanges. Lug type with threaded holes which allows valve to be used as end-of-line valve. Also available with double-flanged connections. Metal to metal sealing or soft sealing. Available with different types of actuators.



BUTTERFLY VALVE

750709
JIS10K/JIS5K

FLANGED ENDS

DESCRIPTION: Nodular cast iron body, vulcanized liner double flanged butterfly valve with ALBr disc. Centric free stem with standardized pattern for actuator mounting.

APPLICATION: Start/stop flow: Sea water, water etc.
Suitable as sea direct.

STANDARD & DESIGN:

Design Code: JIS F7480-1996
 Inspection Std.: JIS F7400
 End Std.: JIS 5K/10K
 Face to Face Std.: JIS B2002
 Flanges drilled: JIS 10K(DN50-DN550)
 JIS 5K(DN50-DN550)
 Pressure rating: JIS 10K(DN50-DN550)
 JIS 5K(DN50-DN550)
 Top flange: ISO 5211(DN50-DN550)

VARIATIONS: With handlever
 Various actuators and gearboxes.
 Other dimensions on request.

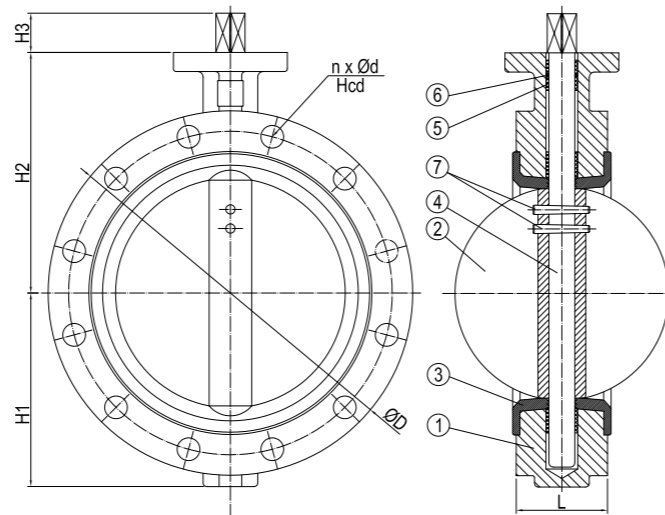
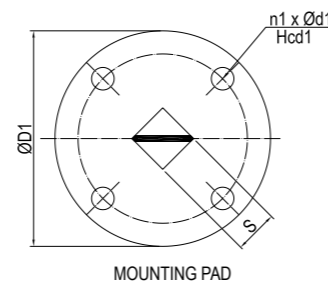
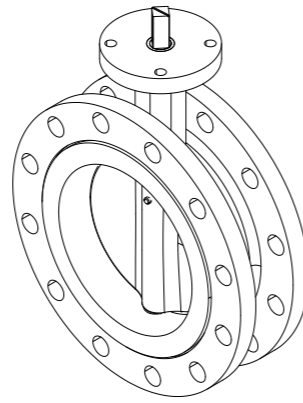

No	Part	Material	Code
1	Body	Nodular Cast Iron	GGG40.3
2	Disc	Al Bronze Alloy	-
3	Seat	NBR	-
4	Stem	Monel K500	-
5	Bushing	Brass	-
6	O-Ring	NBR	-
7	Pin	Monel K500	-

DN	JIS 5K		JIS 10K		øD	n1 x ød1	Hcd1	øD1	L	H1	H2	H3	S	Kg
	n x ød	Hcd	n x ød	Hcd										
50	4x15	105	4x19	120	155	4x7	50	90	40	80	110	32	9	6
65	4x15	130	4x19	140	175	4x7	50	90	40	87	125	32	11	8
80	4x19	145	8x19	150	185	4x9	70	90	60	90	138	32	14	12
100	8x19	165	8x19	175	210	4x9	70	90	60	105	153	32	14	13
125	8x19	200	8x23	210	250	4x9	70	90	100	125	169	32	14	18
150	8x19	230	8x23	240	280	4x9	70	90	100	140	182	32	17	19
200	8x23	280	12x23	290	330	4x9	70	90	100	165	215	40	17	37
250	12x23	345	12x25	355	400	4x11	102	125	110	200	264	40	22	43
300	12x23	390	16x25	400	445	4x11	102	125	110	220	284	45	22	52
350	12x25	435	16x25	445	490	4x17.5	140	175	120	245	324	45	27	70
400	16x25	495	16x27	510	560	4x17.5	140	175	130	280	370	45	27	93
450	16x25	555	20x27	565	620	4x22	165	210	150	310	393	55	36	132
500	20x25	605	20x27	620	675	4x22	165	210	160	337	428	55	36	182
550	20x27	665	20x33	680	745	4x22	165	210	170	372	466	55	36	225

ACTUATORS

For any standard of valves we supply pneumatic, electric, and hydraulic actuators. The actuators are available as quarter turn for ball valves and butterfly valves. Also linear or multi-turn for globe valves and gate valves. In our workshop we adjust valves to fit existing actuators or actuators to fit existing valves. We also supply additional related equipments such as:

- Solenoid valves
- Limit switches
- Positioners
- Mounting kits





ACTUATORS



ELECTRIC ACTUATOR

SA SERIES

- Designed for small quarter-turn applications. This actuator can also automate valves requiring up to 270-degrees rotation.
- Engineered to be lightweight and compact for greater versatility.
- The unique housing design allows various options to be installed without the additional cost of an external enclosure.
- 4-LED lights are located inside the high impact dome indicator. When the actuator reaches the full open or full close position, the dome lights will illuminate and allow added visibility over a greater distance or in low light areas.
- To help protect the components and extend the actuator's life, a 5-watt anti-condensation heater is included as standard.
- Included with the end of travel motor switches are two additional dry-contacts for auxiliary indication.
- A thermal protector is provided to protect the motor from over heating.
- The worm gear drive eliminates the possibility of back drive and the need for motor brakes.
- Designed for mounting in any orientation.
- In case of a power loss, the manual over-ride is provided for positioning the valve.
- 3 ISO mounting pads are provided for greater flexibility.



SA005/SA009

SA005L/SA009L



SA003

OPTIONS

		SA005/ SA009	SA005L/ SA009L
P . I . U	Potentiometer Unit (1K-Ohm)		•
C . P . T	Current Position Transmitter Output DC 4-20mA		•
P . C . U	Proportional Control Unit Input : DC 4-20mA, 2-10V, 1-5V Output : DC 4-20mA		•
L . C . U	Local Control Unit		•
R . B . P	Rechargeable Battery Pack		•

PERFORMANCE

Model	Output Torque		Operating Time(90°)				Motor Class (W)				Rated Current(A)				Duty Cycle		No. of Handle Turns	Weight Kg								
			1 Phase (AC)		DC		1 Phase (AC)		DC		1 Phase (AC)		DC													
	Kg-m	N-m	60 Hz	50 Hz	12 V	24 V	24 V	110 V	220 V	12 V	24 V	24 V	110 V	220 V	12 V	24 V	S2 (min)	S4 (%)								
SA003	3	30	9sec (24V AC)	-	-	-	-	-	-	-	-	-	-	-	-	-	-	-	-	-						
			-	10	-	-	-	-	-	-	-	-	-	-	-	-	-	-	-	-	-					
			-	-	7	18	18	18	18	18	18	18	18	18	18	18	18	18	1	0.2	0.11	0.8	15	50	7.5	1.5
			12sec (110V AC)	-	-	-	-	-	-	-	-	-	-	-	-	-	-	-	-	-	-					
SA005	5	50	12sec (220V AC)	-	-	-	-	-	-	-	-	-	-	-	-	-	-	-	-	-						
			14	17	11	10	15	6	6	6	15	1.8	0.35	0.23	3.2	1.8	15	50	6	2.8						
SA005L	5	50	14	17	11	10	15	6	6	6	15	1.8	0.35	0.23	3.2	1.8	15	50	6	3.2						
SA009	9	90	26	32	25	22	15	6	6	6	15	2.1	0.35	0.25	3.4	2.1	15	30	4.5	2.8						
SA009L	9	90	26	32	25	22	15	6	6	6	15	2.1	0.35	0.25	3.4	2.1	15	30	4.5	3.2						



ELECTRIC ACTUATOR

SA SERIES

STANDARD SPECIFICATION

SA005/SA009	Indicator	Dome type (LED light inside)
	Ambient Temperature	-20°C to 70°C
	Limit Switches	2 Open/Close + Dry contact 2 Open/Close
	Manual operation	By L-wrench (6mm hexagon)
	Space heater	5W (110/230VAC, 24VDC)
	Lubrication	Shell Gadus S2 V220 2
	Surface treatment	Anodizing
	Enclosure	Weatherproof enclosure IP67 Nema 4 and 6
	Power supply	AC 110/230V 1PH ±10% 50/60Hz, DC24(AC24V)
	Travel angle	90° C ± 5° (Extention : upto 270°)
SA003	Self locking	Provided by means of worm gearing
	Conduit entries	Two PF1/2" (Option : M20x1.5, NPT1/2")
	Consist of Materials	Steel, Aluminium alloy, Bronze
	External coating	Polyester (TGIC-free)
	Indicator	Dome type (LED light inside)
	Ambient Temperature	-20°C to 70°C
	Limit Switches	2 Open/Close + Dry contact 2 Open/Close
	Manual operation	By L-wrench (6mm hexagon)
	Space heater	2 x 1.5W
	Lubrication	Shell Gadus S2 V220 2
SA003	Surface treatment	Anodizing
	Enclosure	Weatherproof enclosure IP67 Nema 4 and 6
	Power supply	AC 110/230V 1PH ±10% 50/60Hz, AC24V, DC12V, DC24V
	Travel angle	90° C ± 5° (Extention : upto 270°)
	Self locking	Provided by means of magnetic in motor
	Conduit entries	1-PF1/2" (Option : 1-M20x1.5, 1-NPT1/2") Option: 2-PF1/2", 2-M20x1.5, 2-NPT1/2"
	Consist of Materials	Aluminium alloy
	External coating	Polyester (TGIC-free)



ELECTRIC ACTUATOR

SA SERIES

DIMENSIONS

SA005, SA009

SA005L, SA009L

BASE (OPTION)

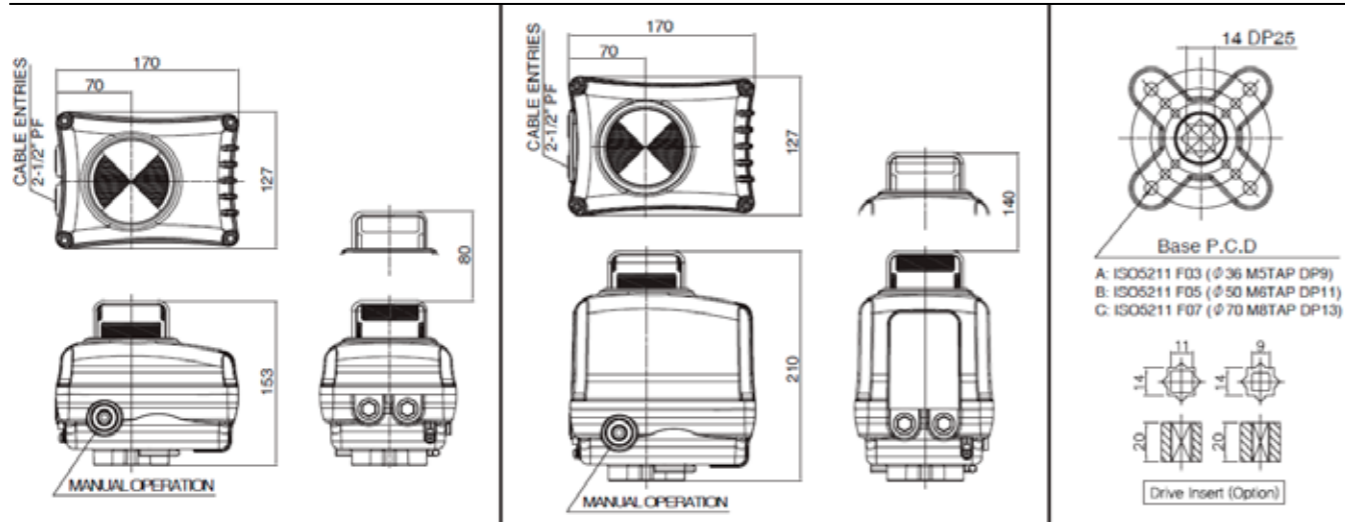

SA003

BASE

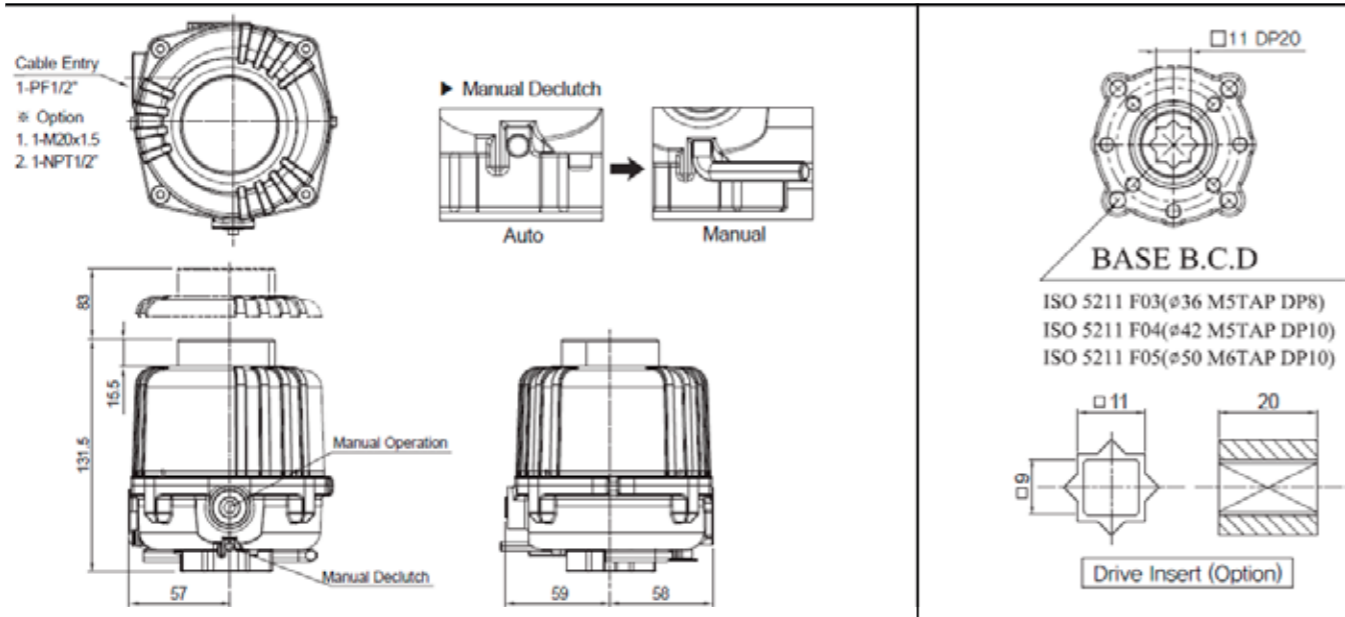

ELECTRIC ACTUATOR

NA SERIES

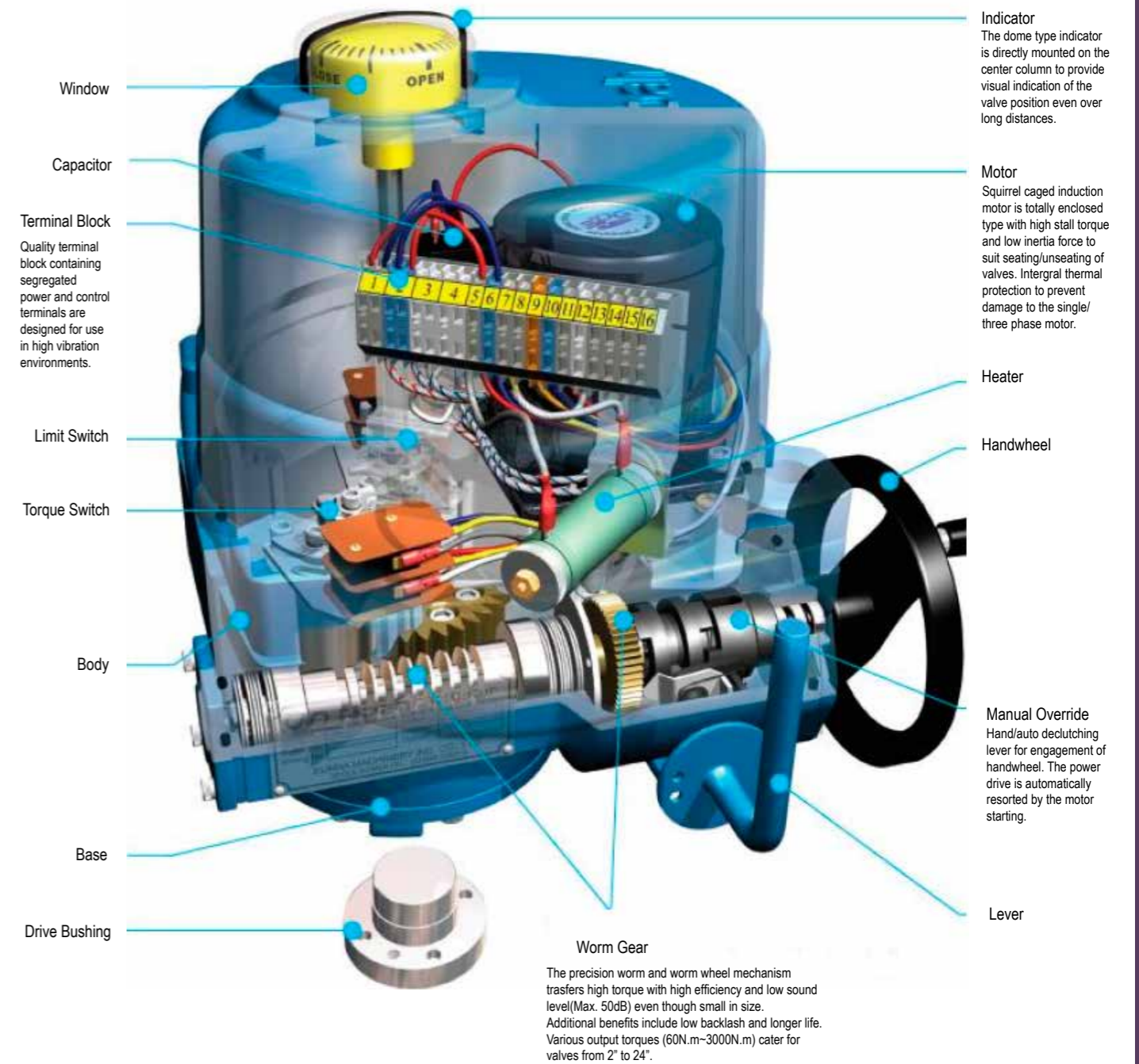



ELECTRIC ACTUATOR

NA SERIES

Standard Specification	
Enclosure	Watertight Ingress Protection 67 Nema 4 and 6
Ambient Temperature	-20°C to +70°C, 150°C / 1hr (Option: -60°C, 400°C / 1hr)
Power Supply	110 / 220 VAC 50/60Hz, 380 / 440 VAC 50/60Hz Option: AC 24V, DC 24V
Torque Switches	2 Open / Close (Except NA006,NA009)
Limit Switches	2 Open / Close , 250 VAC 15A Rating
Stall Protection	Built - in Thermal Protection (Open 150°C ± 5°C / Close 97°C ± 15°C)
Travel Angle	90 ± 5°C
Indicator	Continuous Position Indicator
Manual Override	Hand / Auto Decutching Mechanism
Self Locking	Provided by means of Worm Gearing
Mechanical Stops	External Adjustable Screws
Space Heater	20W
Conduit Entries	2-PF 3/4", 2-NPT 3/4", 2-M20 x1.5(Pitch)
Lubrication	Shell Gadus S2 V220 2
Material	Aluminium
Surface Treatment	Anodizing
External Coating	Polyester (TGIC-Free)

Optional Specification	
EXP	Explosion Proof / Ex d IIB T4
IP68	Watertight Enclosure IP68 / 1bar 72h (KTL)
ALS	Auxiliary Open, Close Limit Switches
ATS	Auxiliary Open, Close Torque Switches
PIU	Potentiometer 1K Ohm
PCU	Proportional Control Unit / Input : DC 4-20mA, DC 1~5V, DC 2~10V / Output: DC 4-20mA
CPT	Current Position Transmitter
LCU	Local Control Unit
IMS	Integral Motor Starter (On-Off Action)
EXT	Travel Angle(120°, 135°, 180°, 270°, 300°)
DCM	Power Supply DC 24V (NA006~NA028)
Field-Bus	Profi-Bus, Mod-Bus, Can-Bus

PERFORMANCE

Type	Max. Output Torque		Operating Time (90/sec)		Rated Current(A)						Motor		Duty Cycle (CSA)	Max. Stem Dia. mm	Handle Turns	Weight Kg
	Kg.m	N.m	50 Hz	60 Hz	DC 24V	AC 110V	AC 220V	AC 230V	AC 380V	AC 440V	W	Class				
NA006	6	60	17	14	2.5	0.7	0.38	0.38	0.15	0.15	15	F	50	22	8.5	9.0
NA009	9	90	17	14	3.5	1.1	0.51	0.56	0.18	0.18	25	F	50	22	8.5	9.0
NA015	15	150	20	17	4.5	1.6	0.75	0.75	0.3	0.3	40	F	50	22	10	11.5
NA019	19	190	20	17	4.5	1.6	0.75	0.75	0.3	0.3	40	F	50	22	10	11.5
NA028	28	280	24	20	6.5	1.6	0.75	0.75	0.32	0.32	40	F	50	32	12.5	14.0
NA038	38	380	24	20	-	2.3	1.1	1.06	0.34	0.34	60	F	30	32	12.5	14.0
NA050	50	500	24	20	-	3.5	1.2	1.2	0.47	0.47	90	F	25	32	12.5	14.0



ELECTRIC ACTUATOR

NA SERIES

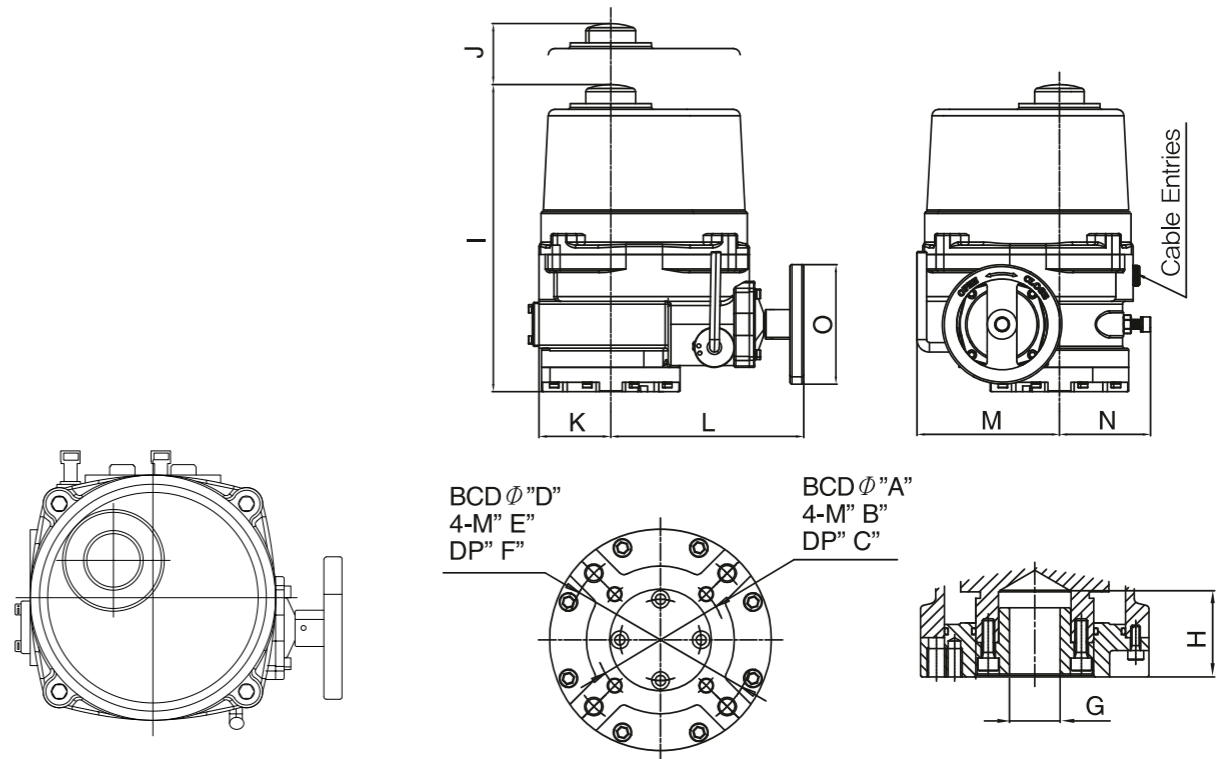

Type	NA006 NA009	NA015 NA019	NA028 NA038 NA050
A	BCD70	BCD70	BCD102
B	4-M8	4-M8	4-M10
C	12	12	18
Flange ISO5211	F07	F07	F10
D	D1	BCD102	BCD125
E	E1	4-M10	4-M12
F	F1	15	18
Flange ISO5211	-	F10	F12
Option	BCD82	BCD82	-
G(MAX)	Key	22	32
	Square	20	26
H	46	46	55
I	270	274	321
J	108	108	130
K	55	70	75
L	174	184	202
M	120	139	149
N	68	85	95
O	102	102	125
Cable Entries	2-PF3/4"	2-PF3/4"	2-PF3/4"
	2-M20x1.5	2-M20x1.5	2-M20x1.5
	2-NPT3/4"	2-NPT3/4"	2-NPT3/4"



HYDRAULIC ACTUATOR

SINGLE ACTING TYPE

SHA/S



WORKING PRESSURE: 6.0 MPa to 12.5 MPa

WORKING TEMPERATURE:
 NBR O-Rings (standard) -20°C to 70°C
 Viton O-Rings (optional) -40°C to 145°C

HYDRAULIC OIL: Viscosity range 15 to 64 cSt. acc. to thermal environment

Rotation: 90° ± 3°
 Closing direction: Clockwise
 Painting: 2-comp. epoxy primer
 Male stud coupling: OD8 to OD12

- OPTIONS:**
- Sea water resistant shaft.
 - Male stud coupling in stainless steel.
 - Electric limit switches IP 65, IP 68 or IP 67 Eex.
 - Proximity switches IP 68.
 - Position Indication by volume indicator or pressure switches.
 - Control blocks.
 - Set for submerged installation.
 - Electro-hydraulic aggregate.
 - Special coating for wet conditions.

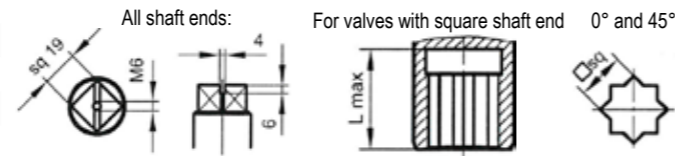
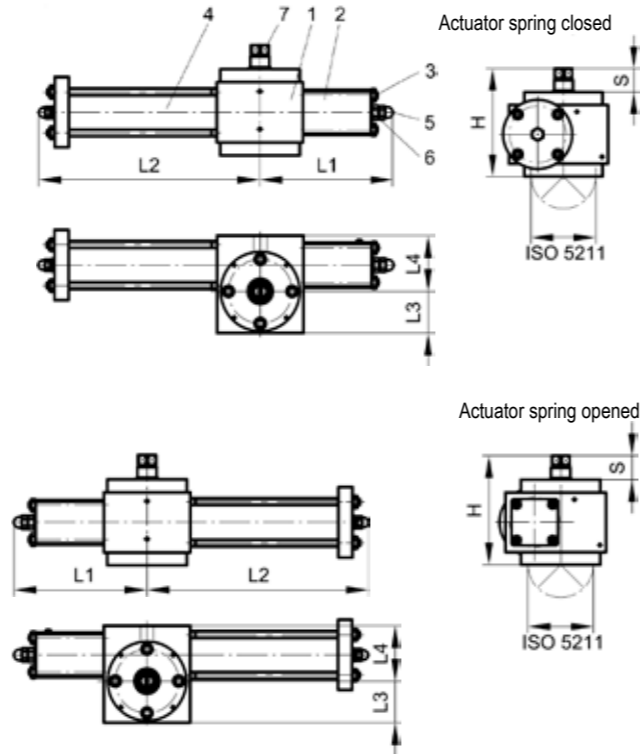

Item	Part	Material 1	Material 2
1	Body	EN-GJL250	EN-GJS400-18
2	Cover	EN-GJL250	EN-GJS400-18
3	Tie Bolts	42CrMo4	42CrMo4
4	Cylinder	Steel	Steel
5	Cap Nuts	Stainless Steel	Stainless Steel
6	Hexagonal Nuts	Stainless Steel	Stainless Steel
7	Shaft	Stainless Steel	Stainless Steel

FOR MOUNTING ON FLANGES ACCORDING TO DIN 5211

Size	Torque ²⁾ [Nm]		Stroke volume [cm ³]	L1	L2	L3	L4	H	S	ISO 5211	Weight (Kg)
	Open	Close									
40-78 SC	320	78	68	216	273	63	87	174	36.5	F05 or F07/F10	27
40-78 SO	78	320	68	216	273	63	87	174	36.5	F05 or F07/F10	27
40-190 SC	210	190	68	216	348	63	87	174	36.5	F07/F10	29
40-190 SO	190	210	68	216	348	63	87	174	36.5	F07/F10	29
63 SC	640	360	169	216	378	63	87	174	36.5	F07/F10 or F12	32
63 SO	360	640	169	216	378	63	87	174	36.5	F07/F10 or F12	32
70 SC	1400	600	282	430	430	89	105	174	36.5	F10/F14 or F12	50
70 SO	600	1400	282	430	430	89	105	174	36.5	F10/F14 or F12	50

2) For control pressure 10.5 MPa.

SHAFT CONNECTION

Size	□sq						L _{max}
40	14	16	17	19	22	27	40
63	22	24	27	30	-	-	40
70	22	24	27	30	-	-	40



HYDRAULIC ACTUATOR

SINGLE ACTING TYPE

SHA/S



WORKING PRESSURE: 6.0 MPa to 12.5 MPa

WORKING TEMPERATURE:
 NBR O-Rings (standard) -20°C to 70°C
 Viton O-Rings (optional) -40°C to 145°C

HYDRAULIC OIL: Viscosity range 15 to 64 cSt. acc. to thermal environment.

TECHNICAL DATAS:
 Rotation: 90° ± 3°
 Closing direction: Clockwise
 Painting: 1-comp. epoxy thick film coat.
 Male stud coupling: OD8 to OD12

- OPTIONS:**
- Sea water resistant shaft.
 - Male stud coupling in stainless Steel.
 - Electric limit switches IP65, IP 68 or IP 67 Eex.
 - Proximity switches IP 68.
 - Position indication by volume indicator or pressure switches.
 - Control blocks.
 - Set for submerged installation.
 - Electro-hydraulic aggregate.
 - Special coating for wet conditions.

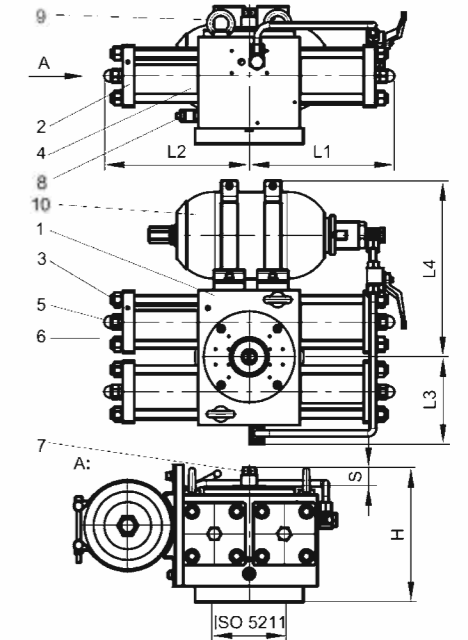

Item	Part	Material 1	Material 2
1	Body	EN-GJL250	EN-GJS400-18
2	Cover	EN-GJL250	EN-GJS400-18
3	Tie Bolts	42CrMo4	42CrMo4
4	Cylinder	Steel	Steel
5	Cap Nuts	Stainless Steel	Stainless Steel
6	Hexagonal Nuts	Stainless Steel	Stainless Steel
7	Shaft	Stainless Steel	Stainless Steel
8	Check Valve	Stainless Steel	Stainless Steel
9	Lifting Eyes	Steel	Steel
10	Bladder	Steel	Steel

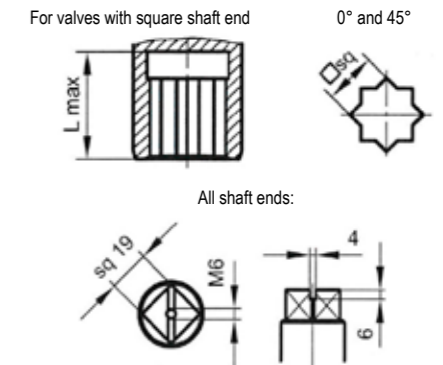

FOR MOUNTING ON FLANGES ACCORDING TO DIN 5211

Size	Torque ²⁾ [Nm]		Stroke volume [cm ³]	L1	L2	L3	L4	H	S	ISO 5211	Weight (Kg)
	Open	Close									
80 SC	1430	1170	473	282	282	169	305	263	36	F12 or F14 or F16	111
80 SO	1170	1430	473	282	282	169	305	263	36	F12 or F14 or F16	111
160 SC	2860	2340	946	282	282	169	342	267	36	F14 or F16 or F25	161
160 SO	2340	2860	946	282	282	169	342	267	36	F14 or F16 or F25	161
200 SC	9420	6280	2764	462	462	235	412	480	36	F16 ³⁾ or F25 or F30	415
200SO	6280	9420	2764	462	462	235	412	480	36	F16 ³⁾ or F25 or F30	415

2) For control pressure 10.5 MPa.

3) H = 450, Weight = 365

SHAFT CONNECTION

Size	□sq						L _{max}
80	24	27	30	36	40	40	60
160	24	27	32	36	40	40	60
200	Upon request						110



HYDRAULIC ACTUATOR

DOUBLE ACTING TYPE

SHA/D

WORKING PRESSURE: 6.0 MPa to 12.5 MPa

WORKING TEMPERATURE:

NBR O-Rings (standard) -20°C to 70°C
 Viton O-Rings (optional) -40°C to 145°C

HYDRAULIC OIL: Viscosity range 15 to 64 cSt. acc. to thermal environment

TECHNICAL DATA:

Rotation: 90° ± 3°
 Closing direction: Clockwise
 Painting 32-63: 2-comp. epoxy primer
 Painting 80: 1-comp. thick film epoxy coat.
 Male stud coupling: OD8 to OD12
 Two pcs. quick couplings for emergency operation
 Two pcs. throttle valve for speed regulation

- OPTIONS:**
- Male stud coupling in stainless steel.
 - Electric limit switches IP 65, IP 68, or IP 67 Eex.
 - Proximity switches IP 68.
 - Position indication by analog transmitter or potentiometer.
 - Set for submerged installation.
 - Electro-hydraulic aggregate.
 - Special coating for wet conditions.

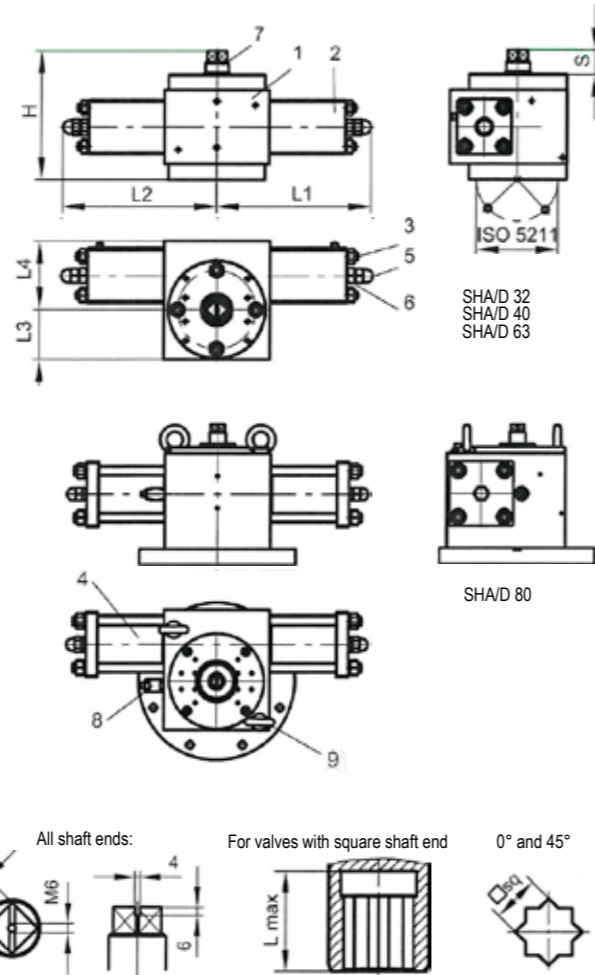

Item	Part	Material 1	Material 2
1	Body ¹⁾	EN-GJL250	EN-GJS400-18
2	Cover ¹⁾	EN-GJL250	EN-GJS400-18
3	Tie Bolts	Stainless Steel	42CrMo4
4	Cylinder	Steel	Stainless Steel
5	Cap Nuts	Stainless Steel	Stainless Steel
6	Hexagonal Nuts	Stainless Steel	Stainless Steel
7	Shaft	Stainless Steel	Stainless Steel
8	Check Valve	Stainless Steel	Stainless Steel
9	Lifting Eyes ²⁾	Steel	Steel

1) Material of Body and Cover for SHA/D 32: 9S20K.
 2) Provided only for SHA/D 80.

FOR MOUNTING ON FLANGES ACCORDING TO ISO 5211

Size	Torque (Nm) ²⁾	Stroke volume (cm ³)	L1	L2	L3	L4	H	S	ISO 5211	Weight (Kg)
32	120	30	143	143	40	72	137	46	F05/F07	9
40	400	68	196	196	63	88	165	36.5	F07/F10 or F12	25
63	1000	169	196	196	63	94	174	36.5	F10/F14 or F12 or F16	30
80	2600	473	280	280	90	132	261	36	F14 or F16	90

2) For control pressure 10.5 MPa.

SHAFT CONNECTION

Size	□sq						L _{max}
32	9	10	11	12	14	-	34
40	14	16	17	19	22	27	40
63	22	24	27	30	-	-	40
80	24	27	30	36	40	-	60



HYDRAULIC ACTUATOR

DOUBLE ACTING TYPE

SHA/D

WORKING PRESSURE: 6.0 MPa to 12.5 MPa

WORKING TEMPERATURE:

NBR O-Rings (standard) -20°C to 70°C
 Viton O-Rings (optional) -40°C to 145°C

HYDRAULIC OIL: Viscosity range 15 to 64 cSt. acc. to thermal environment.

TECHNICAL DATA:

Rotation: 90° ± 3°
 Closing direction: Clockwise
 Painting 70: 2-comp. epoxy primer
 Painting 160-200: 1-comp. thick film epoxy coat.
 Male stud coupling: OD8 to OD12
 Two pcs. quick couplings for emergency operation
 Two pcs. throttle valve for speed regulation
 Two pcs. internal oil filters

- OPTIONS:**
- Male stud coupling in stainless steel.
 - Electric limit switches IP 65, IP 68, or IP 67 Eex.
 - Proximity switches IP 68.
 - Position indication by analog transmitter or potentiometer.
 - Set for submerged installation.
 - Electro-hydraulic aggregate.
 - Special coating for wet conditions.

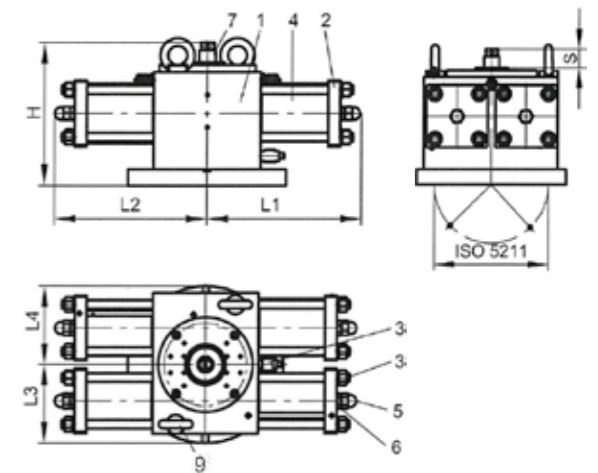

Item	Part	Material 1	Material 2
1	Body	EN-GJL250	EN-GJS400-18
2	Cover	Steel	Steel
3	Tie Bolts	Stainless Steel	42CrMo4
4	Cylinder	Steel	Stainless Steel
5	Cap Nuts	Stainless Steel	Stainless Steel
6	Hexagonal Nuts	Stainless Steel	Stainless Steel
7	Shaft	Stainless Steel	Stainless Steel
8	Check Valve	Stainless Steel	Stainless Steel
9	Lifting Eyes ¹⁾	Steel	Steel

1) Only SHA/D 160 and 200.

FOR MOUNTING ON FLANGES ACCORDING TO ISO 5211

Size	Torque (Nm) ²⁾	Stroke volume (cm ³)	L1	L2	L3	L4	H	S	ISO 5211	Weight (Kg)
70	2000	338	219	210	93	123	172	36.5	F12 or F14	48
160	5200	946	282	282	145	145	260	36	F14 or F16 or F25	103
200	15700	2764	462	462	198	228	404	36	F25 or F30 or F40	371

2) For control pressure 10.5 MPa.

SHAFT CONNECTIONA

Size	□sq						L _{max}
70	22	24	27	30	-	-	40
160	24	27	32	36	40	-	60
200	Upon request						110



PNEUMATIC ACTUATOR

MVS/MVD

SINGLE ACTING SPRING RETURN/DOUBLE ACTING

SIZING EXAMPLE OF DOUBLE ACTING ACTUATOR:

Valve torque 100Nm + 30% safety factor = 130Nm.
 Minimum operating pressure is 5bar (70psig).
 By reading down the 5 bar(70psig) column in the table below, 163Nm is the next value greater than 130Nm, hence the model number shown in the left hand column is VS-105DA.

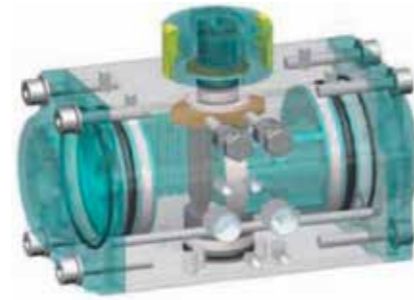

The operating principle of a Double acting Actuator

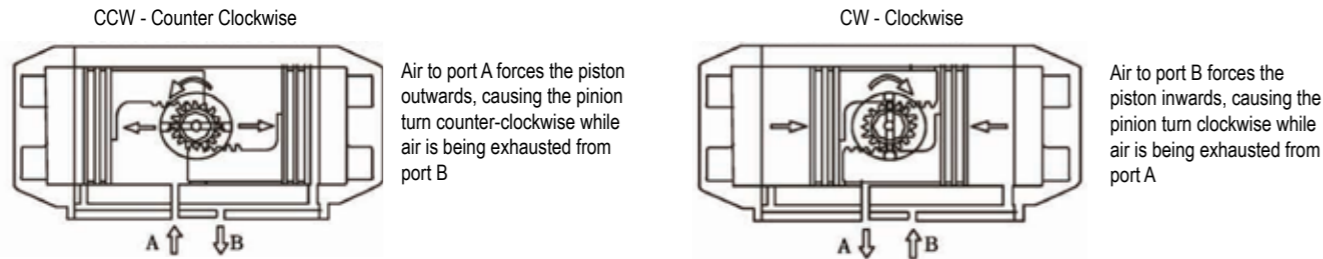

TORQUE TABLE OF DOUBLE ACTING ACTUATOR

Unit: Nm / in.lbs

Model	Air Supply Pressure(bar/psig)					
	3.0/42.6	4.0/58.9	5.0/71.1	6.0/85.3	7.0/99.6	8.0/113.8
MVD032DA	4.6	6.1	7.6	9.2	10.7	12.2
MVD052DA	12.0	16.0	20.0	24.0	28.0	32.0
MVD063DA	21.7	28.9	36.1	43.4	50.6	57.8
MVD075DA	35.0	46.6	58.3	69.9	81.6	93.2
MVD083DA	42.8	57.0	71.3	85.5	99.8	114.0
MVD092DA	67.6	90.1	112.6	135.2	157.7	180.2
MVD105DA	97.7	130.3	162.9	195.5	228.0	260.6
MVD125DA	173.3	231.0	288.8	346.5	404.3	462.0
MVD140DA	260.7	347.6	434.5	521.4	608.3	695.2
MVD160DA	397.2	529.6	662.0	794.4	926.8	1059.2
MVD190DA	640.2	853.6	1067.0	1280.4	1493.8	1707.2
MVD210DA	798.0	1064.0	1330.0	1596.0	1862.0	2128.0
MVD240DA	1154.3	1539.0	1923.8	2308.5	2693.3	3078.0
MVD270DA	1939.2	2585.6	3232.0	3878.4	4524.8	5171.2
MVD300DA	2291.4	3055.2	3819.0	4582.8	5346.6	6110.4
MVD300DA	20278.9	27038.5	33798.2	40557.8	47317.4	54077.0



PNEUMATIC ACTUATOR

MVS/MVD

SINGLE ACTING SPRING RETURN/DOUBLE ACTING

SIZING EXAMPLE OF A SPRING RETURN ACTUATOR:

Spring to close when air fails (air to open).
 Valve torque 60Nm + 20% safety factor = 72Nm.
 Minimum operating pressure: 6 bar (87psig).
 The spring return actuator selected is VS-105-SR12.
 The VS-105-SR12 has the following output torques
 1. air torque 0°(valve close) = 124Nm > 72Nm
 2. air torque 90°(valve open)= 84Nm
 3. spring torque 90°(valve open)=120Nm
 4. spring torque 0°(valve close)=80Nm>72Nm.



The operating principle of single acting spring return actuator

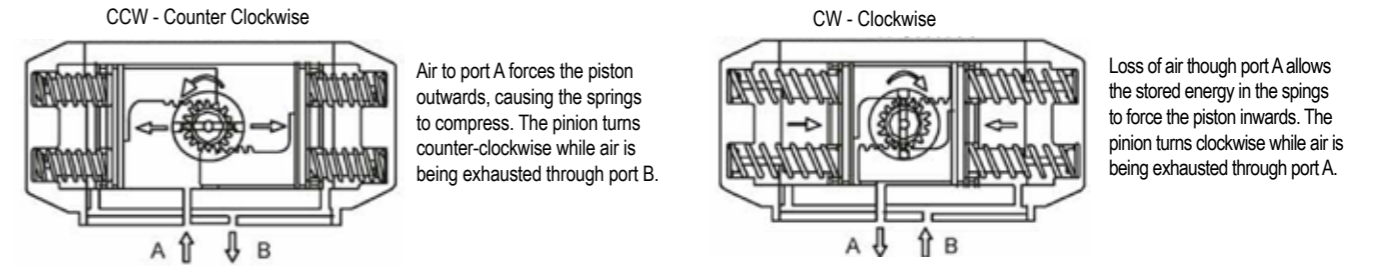

Model	Spring Torque (in.lbs)	Air Supply Pressure(psig)										
		60		70		80		90		100		
		0°	90°	0°	90°	0°	90°	0°	90°	0°	90°	
MVS052SR	70	110	79	39	104	64	129	89	154	114	179	139
MVS063SR	125	191	144	78	189	123	234	168	279	213	324	258
MVS075SR	190	260	244	175	318	248	390	320	462	393	535	465
MVS083SR	264	364	271	168	359	256	448	345	718	615	625	522
MVS092SR	407	583	434	258	574	398	714	538	854	678	993	818
MVS105SR	562	873	654	343	857	546	1060	749	1262	951	1465	1155
MVS125SR	1018	1527	1138	629	1497	988	1856	1347	2216	1707	2576	2067
MVS140SR	1538	2301	1706	943	2247	1484	2788	2025	3329	2565	3870	3106
MVS160SR	2379	3481	2564	1462	3388	2286	4212	3110	5036	3935	5860	4759
MVS190SR	3795	5638	4172	2329	5500	3657	6828	4985	8156	6313	9484	7641
MVS210SR	5211	7767	5739	3183	7564	5008	9389	6833	11214	8658	13039	10483
MVS240SR	8187	12144	8975	5019	11835	7879	14695	10739	17556	13599	20415	16459
MVS270SR	11573	17023	12562	7112	16585	11135	20607	15157	24631	19181	28653	23203

Model	Spring Torque (Nm)	Air Supply Pressure (bar)								
		4.0		5.0		6.0		7.0		
		0°	90°	0°	90°	0°	90°	0°	90°	
MVS052SR	7.9	12.4	8.1	3.6	12.1	7.6	16.1	11.6	20.1	15.6
MVS063SR	13.7	20.9	15.2	8.0	22.4	15.2	29.7	22.5	36.9	29.7
MVS075SR	21.1	32.5	25.5	14.1	37.2	25.8	48.8	37.4	60.5	49.1
MVS083SR	29.5	41.1	27.5	15.9	41.8	30.2	56	44.4	70.3	58.7
MVS092SR	46.0	65.9	44.1	24.2	66.6	46.7	89.2	69.3	111.7	91.8
MVS105SR	63.5	98.6	66.8	31.7	99.4	64.3	132	96.9	164.5	129.4
MVS125SR	105.0	172.5	126	59	184	116	242	174	299	232
MVS140SR	172	258	175	89	262	176	349	263	436	350
MVS160SR	279	385	250	144	383	277	515	409	647	541
MVS190SR	400	640	453	213	667	427	880	640	1093	853
MVS210SR	550	880	622	292	916	586	1209	879	1502	1172
MVS240SR	820	1370	1018	468	1478	928	1937	1387	2397	1847
MVS270SR	1120	1920	1465	665	2110	1310	2756	1956	3403	2603

For all Spring Return Actuators, Spring Set 10 used.



PNEUMATIC ACTUATOR

SINGLE ACTING SPRING RETURN/DOUBLE ACTING

MVS/MVD



LIMIT SWITCH

MTS

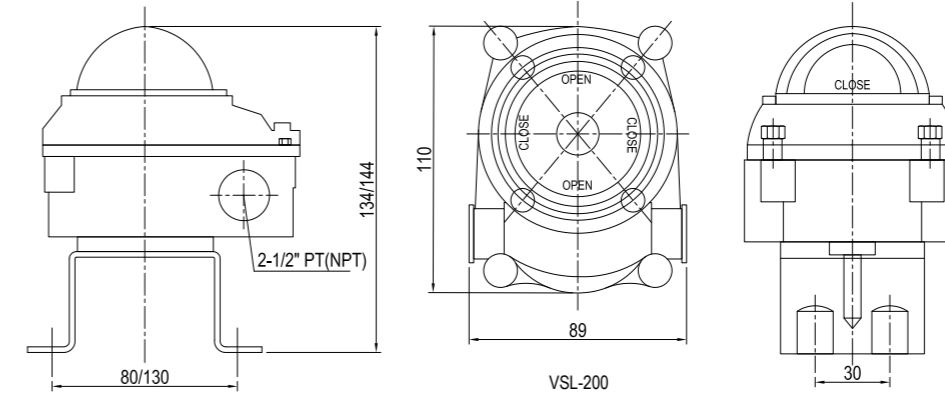
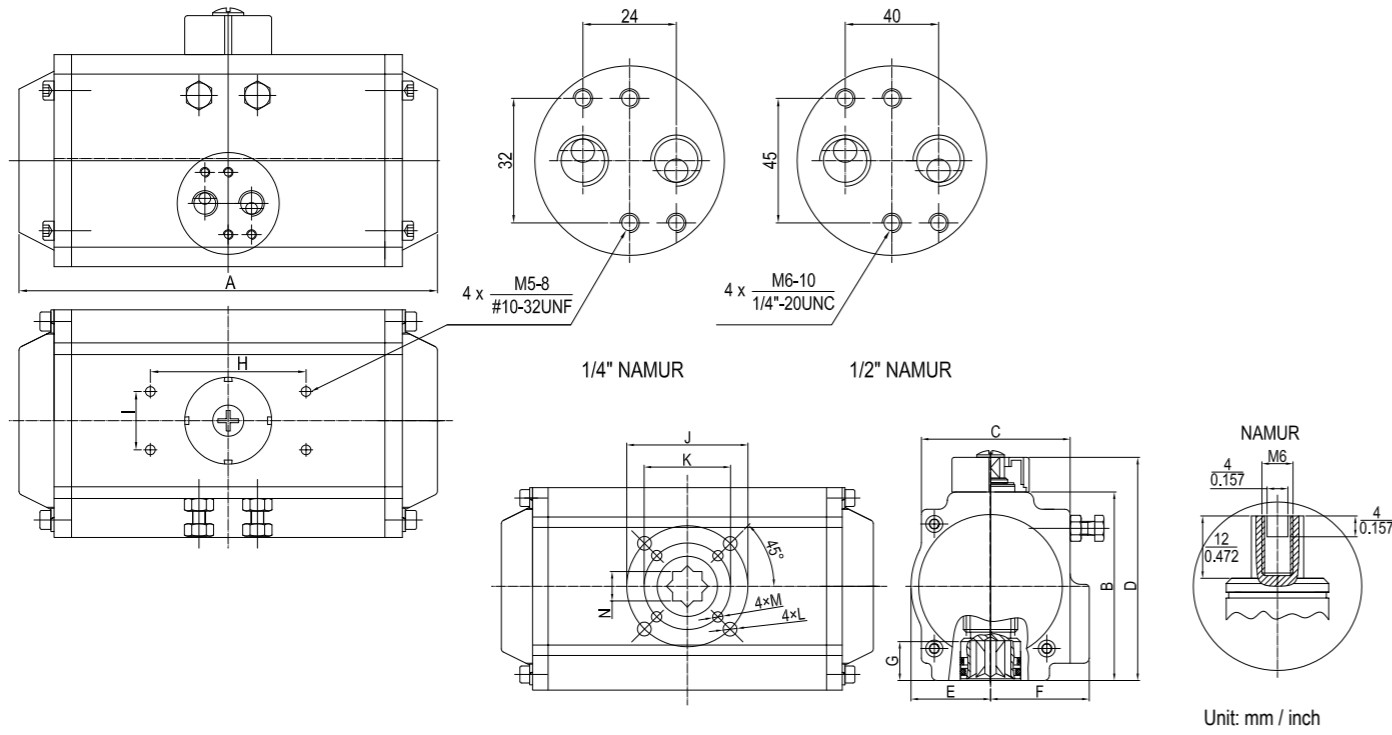

Model	A	B	C	D	E	F	G	H	I	N	A120°	A180°	J	K	L	M	Air Connection
MV-032	110	45	45	65	22.5	22.5	12	50	25	9	-	-	F03	-	M5x7.5	-	1/8"
	4.33	1.77	1.77	2.56	0.89	0.89	0.47	1.97	0.98	0.35	-	-	-	-	#10-24UNF	-	1/8"
MV-052	153	72	65	92	30	41.5	14	80	30	11	182	225	F05	F03	M6x10	M5x7.5	1/8" or 1/4" (std.)
	6.03	2.83	2.56	3.62	1.18	1.63	0.55	3.15	1.18	0.43	7.16	8.86	-	-	1/4"-20UNC	#10-32UNF	1/8" or 1/4" (std.)
MV-063	174	88	72	108	36	47	18	80	30	14	216	266	F07	F05	M8x13	M6x10	1/8" or 1/4" (std.)
	6.86	3.46	2.83	4.25	1.42	1.85	0.71	3.15	1.18	0.55	8.50	10.47	-	-	5/16"-20UNC	1/4"-20UNC	1/8" or 1/4" (std.)
MV-075	196	100	81	120	42	53	20	80	30	14	232	282	F07	F05	M8x13	M6x10	1/8" or 1/4" (std.)
	7.72	3.94	3.19	4.72	1.65	2.09	0.79	3.15	1.18	0.55	9.13	11.10	-	-	5/16"-20UNC	1/4"-20UNC	1/8" or 1/4" (std.)
MV-083	208	109	92	129	46	57	21	80	30	17	245	304	F07	F05	M8x13	M6x10	1/8" or 1/4" (std.)
	8.20	4.29	3.62	5.08	1.81	2.24	0.83	3.15	1.18	0.67	9.65	12.0	-	-	5/16"-20UNC	1/4"-20UNC	1/8" or 1/4" (std.)
MV-092	249	117	98	137	50	58.5	22	80	30	17	303	386	F07	F05	M8x13	M6x10	1/8" or 1/4" (std.)
	9.81	4.61	3.86	5.39	1.97	2.30	0.87	3.15	1.18	0.67	12.0	15.2	-	-	5/16"-20UNC	1/4"-20UNC	1/8" or 1/4" (std.)
MV-105	278	133	110	153	58	62	26	80	30	22	330	414	F10	F07	M10x16	M8x13	1/4"
	10.95	5.24	4.33	6.02	2.28	2.44	1.02	3.15	1.18	0.87	13.0	16.3	-	-	3/8"-20UNC	5/16"-20UNC	1/4"
MV-125	326	155	125.5	175	67.5	75	27.5	80	30	22	392	497	F10	F07	M10x16	M8x13	1/4"
	12.84	6.10	4.94	6.89	2.66	2.95	1.08	3.15	1.18	0.87	15.4	19.6	-	-	3/8"-20UNC	5/16"-20UNC	1/4"
MV-140	396	173	137.5	193	75	77	32	80	30	27	475	601	F12	F10	M12x20	M10x16	1/4"
	15.60	6.81	5.41	7.60	2.95	3.03	1.26	3.15	1.18	1.06	18.7	23.7	-	-	1/2"-20UNC	3/8"-20UNC	1/4"
MV-160	457	198	158	218	87	87	34	80	30	27	553	700	F12	F10	M12x20	M10x16	1/4"
	18.01	7.80	6.22	8.58	3.43	3.43	1.34	3.15	1.18	1.06	21.8	27.6	-	-	1/2"-20UNC	3/8"-20UNC	1/4"
MV-190	538	232	189	262	103	103	40	130	30	36	623	790	F14	-	M16x24	-	1/4"
	21.18	9.13	7.44	10.3	4.06	4.06	1.57	3.15	1.18	1.42	24.5	31.1	-	-	5/8"-20UNC	-	1/4"
MV-210	568	257	210	287	113	113	40	130	30	36	662	851	F14	-	M16x24	-	1/4"
	22.36	10.12	8.27	11.30	4.45	4.45	1.57	5.12	1.18	1.42	26.1	33.5	-	-	5/8"-20UNC	-	1/4"
MV-240	660	291	245	321	130	130	50	130	30	46	828	1000	F16	-	M20x26	-	1/4" or 3/8" (std.)
	26.0	11.46	9.65	12.64	5.12	5.12	1.97	5.12	1.18	1.81	32.6	39.4	-	-	3/4"-20UNC	-	1/4" or 3/8" (std.)
MV-270	740	330	273	360	147	147	50	130	30	46	867	1119	F16	-	M20x26	-	1/4" or 1/2" (std.)
	29.13	13.0	10.75	14.17	5.79	5.79	1.97	5.12	1.18	1.81	34.1	44.1	-	-	3/4"-20UNC	-	1/4" or 1/2" (std.)
MV-300	798	354	290	384	90	173	50	130	30	46	-	-	F16	-	M20x26	-	1/2" (std.)
	31.42	15.12	11.42	16.3	3.54	6.81	1.97	5.12	1.18	1.81	-	-	-	-	3/4"-20UNC	-	1/2" (std.)

TECHNICAL SPECIFICATIONS:

Item Type	VSL-200
Enclosure Protection	IP67
Ambient Temperature	-20°C TO 60°C
Conduit Entry	NPT 1/2" (PT1/2", PF1/2", M20)
Terminal	8 Contacts
Mounting Bracket	NAMUR VDI / VDE 3845, ISO 5211
Material	Die Casting Aluminium
Weight	0.5 Kg (1 lb)

Part	Material	Code
Housing	Low Copper Aluminium die-casting	-
Coating	Epoxy-Polyester	-
Sealing	NBR O-Rings on each interface	-
Cams	Poly-Carbonate	-
Bushings	Bronze	-
Shaft	Stainless Steel	AISI304
Earth Lug	Stainless Steel	-
Mounting Bracket	Stainless Steel	AISI304

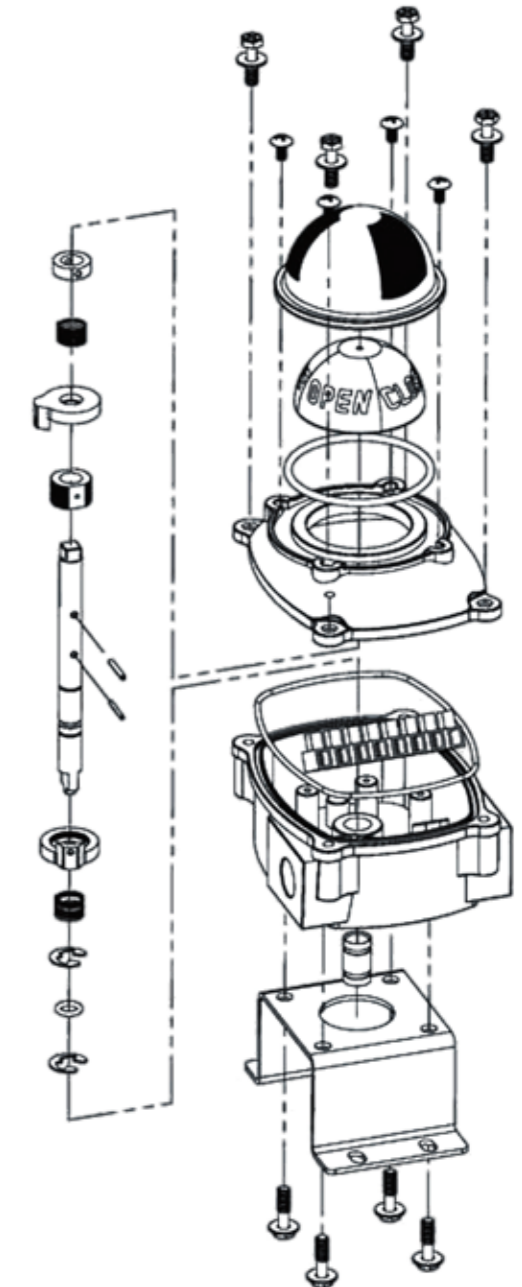



SOLENOID VALVES

MSV

SPECIFICATION

Model	4V310/410	4V320/4V420
Medium	Air	
Operating	Internal Piloted	
Valve Type	5 Port 2 Position	
Orifice Size	35mm ²	
Port Size	PF1/4"	
Lubrication	Not Required	
Pressure Range	0.15 ~ 0.8 Mpa	
Proof Pressure	12bar	
Temp. Range	-5°C ~ 60°C (23°F ~ 140°F)	
Voltage Range	-15% ~ 10%	
Power Consumption	AC = 2.0~3.5VA, DC = 2.5W	
Insulation Class	Class F	
Protection	IP65(DIN40050)	
Connector	Socket with Plug	
Max. Frequency	5 cycle/second	
Specification of Explosion-Proof Type		
Explosion Proof	EExmII T4, T5	
Voltage Range	±10%	
Power Consumption	AC = 4.4W, DC = 5W	
Insulation Class	Class F	



FITTINGS, SPARE PARTS AND MODIFICATION

Independently of which standard of valves you use it is from time to time necessary to repair them or the pipes in which they are mounted. We therefore also supply pipe couplings for mounting or repairing pipes, available for pipe outer diameters from 26,9mm up to 645mm (Larger diameters on request) and furthermore a wide range of pipe fittings in stainless steel. We also supply spare parts for a wide range of valves and actuators. Our knowledge also serves you through our workshops where we arrange modifications and special executions and mount and test actuators. We also modify valves to fit into existing pipe systems and existing actuators.

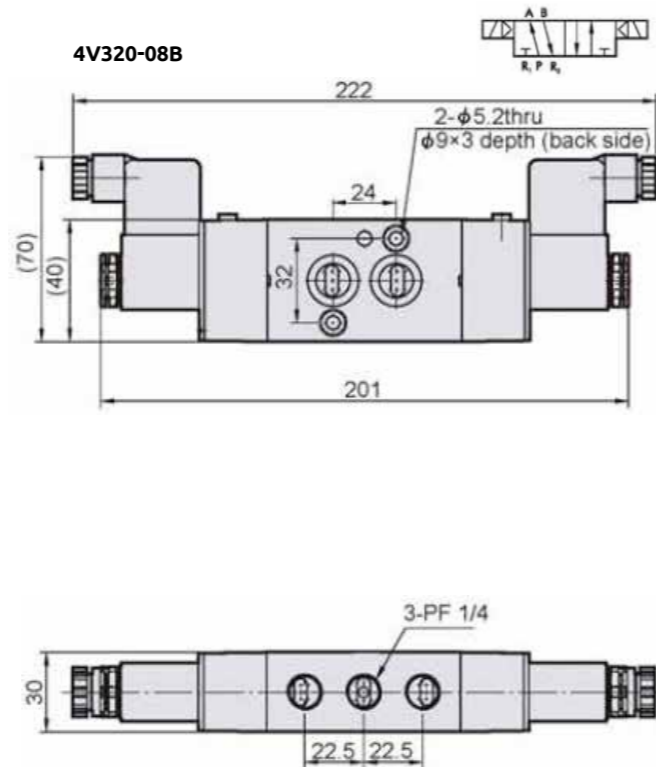
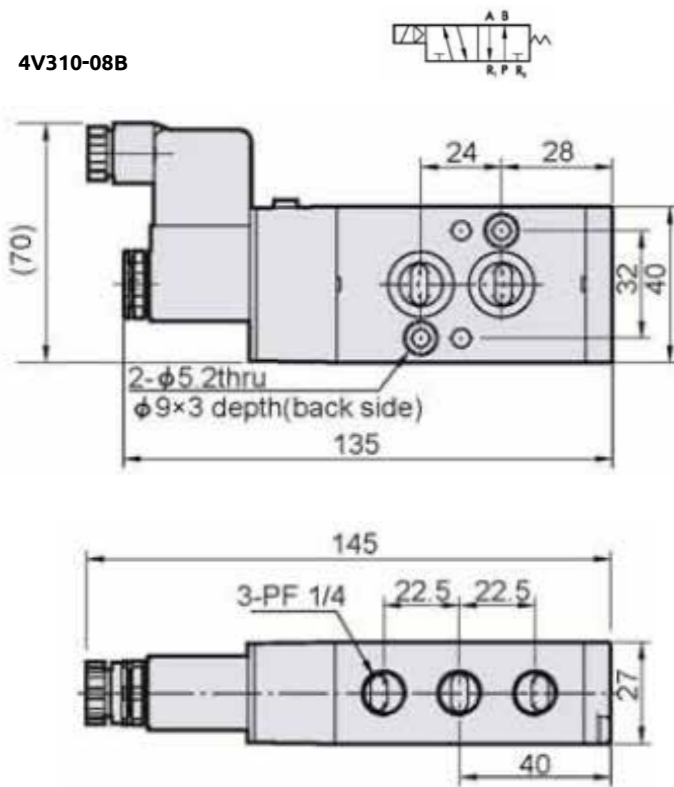



PIPE COUPLINGS & REPAIR COUPLINGS

Pipe couplings for mounting or repairing pipes.
Available for pipe outer diameters from 26,9mm up to 645mm. (Larger diameters on request).
Our pipe couplings can be delivered with type approval certificates from all major classification societies.



GRIP RING COUPLING

800 / 801

Pipe ND	Pipe OD	Coupling range	Working pressure (bar)	L	Kg
DN15	20.0	19.5 ~ 20.5	16	60	0,32
	21.7	21.2 ~ 22.2	16	60	0,32
DN20	25.0	24.5 ~ 25.5	16	60	0,32
	27.2	26.7 ~ 27.7	16	60	0,32
	28.2	27.5 ~ 29.0	16	60	0,32
DN25	30.0	29.5 ~ 30.5	16	60	0,34
	32.0	31.5 ~ 32.5	16	60	0,34
	34.0	33.0 ~ 34.6	16	60	0,34
DN32	38.0	37.5 ~ 38.5	16	60	0,36
	40.0	39.5 ~ 41.5	16	60	0,36
	42.7	41.9 ~ 43.0	16	60	0,36
	44.5	44.0 ~ 45.0	16	60	0,36
DN40	48.6	47.8 ~ 49.0	16	60	0,38
	50.8	49.5 ~ 51.5	16	60	0,38
DN50	54.0	53.4 ~ 54.6	16	80	0,60
	57.0	56.4 ~ 57.6	16	80	0,60
	60.5	59.0 ~ 61.5	16	80	0,60
	63.0	62.4 ~ 63.6	16	80	0,60
DN65	66.7	65.2 ~ 67.3	14	80	0,68
	69.0	68.0 ~ 70.1	14	80	0,68
	73.0	71.5 ~ 74.1	14	80	0,68
	76.3	75.0 ~ 77.2	14	80	0,68
DN80	79.9	78.8 ~ 80.8	14	110	1,38
	84.0	83.0 ~ 84.9	14	110	1,38
	89.1	87.8 ~ 91.0	14	110	1,38
	101.6	100.4 ~ 102.6	14	110	1,38
DN100	104.0	103.0 ~ 104.8	14	110	1,60
	106.3	105.0 ~ 107.4	14	110	1,60
	108.0	106.5 ~ 108.5	14	110	1,60
	114.3	113.2 ~ 115.4	14	110	1,60
DN125	127.0	125.6 ~ 128.4	14	111	2,07
	129.0	127.5 ~ 130.0	14	111	2,07
	133.0	131.6 ~ 134.4	14	111	2,07
	139.8	137.7 ~ 140.9	14	111	2,07
	141.3	139.7 ~ 142.5	14	111	2,07
DN150	154.0	151.5 ~ 155.0	12	111	2,25
	159.0	156.5 ~ 160.0	12	111	2,25
	165.2	163.3 ~ 166.7	12	111	2,25
	168.3	166.6 ~ 170.0	12	111	2,25
DN175	180.0	178.0 ~ 182.0	10	111	2,25
DN200	200.0	198.2 ~ 201.5	8	150	4,73
	204.0	202.7 ~ 206.7	8	150	4,73
	216.3	214.5 ~ 218.3	8	150	4,73
	219.1	217.0 ~ 221.0	8	150	4,73
DN250	254.0	251.4 ~ 256.6	8	150	5,40
	267.4	264.8 ~ 270.0	8	150	5,40
	273.1	270.4 ~ 275.6	8	150	5,40
DN300	304.0	301.5 ~ 306.6	7	150	6,16
	318.5	316.0 ~ 322.0	7	150	6,16
	323.9	321.0 ~ 327.4	7	150	6,16
DN350	355.6	352.0 ~ 360.0	7	150	7,20
DN400	406.4	402.0 ~ 410.0	6	150	7,70

No	Part	Material	Code
1	Grip Ring	Stainless Steel	SS 304
2	Seal	NBR (800) EPDM (801)	

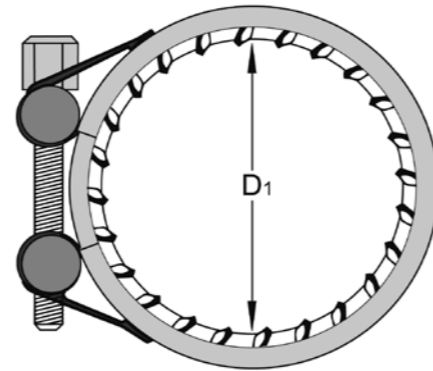
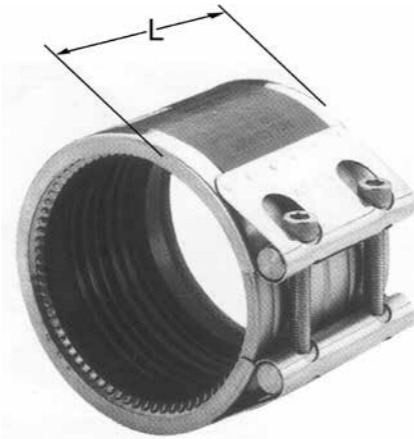

REPAIR COUPLING

810 / 811

Pipe ND	Pipe OD	Coupling range	Working pressure (bar)	L	Kg
DN15	20.0	19.5 ~ 20.5	16	60	0,23
	21.7	21.0 ~ 22.0	16	60	0,23
DN20	25.0	24.0 ~ 26.0	16	60	0,25
	27.2	26.0 ~ 28.0	16	60	0,25
	28.2	26.4 ~ 29.0	16	60	0,25
DN25	30.0	29.0 ~ 31.0	16	60	0,27
	32.0	31.0 ~ 33.0	16	60	0,27
	34.0	33.0 ~ 35.0	16	60	0,27
DN32	38.0	37.0 ~ 39.0	16	60	0,29
	40.0	39.5 ~ 41.3	16	60	0,29
	42.7	42.0 ~ 44.0	16	60	0,29
	44.5	44.0 ~ 46.0	16	60	0,29
DN40	48.6	47.5 ~ 49.5	16	60	0,31
	50.8	49.2 ~ 51.5	16	60	0,31
DN50	54.0	53.0 ~ 55.0	16	80	0,68
	57.0	56.0 ~ 58.0	16	80	0,68
	60.5	59.0 ~ 61.5	16	80	0,68
	63.0	62.0 ~ 64.0	16	80	0,68
DN65	66.7	65.4 ~ 68.3	14	80	0,74
	69.0	68.5 ~ 71.0	14	80	0,74
	73.0	72.5 ~ 75.5	14	80	0,74
	76.3	75.0 ~ 78.0	14	80	0,74
DN80	79.9	78.8 ~ 82.0	14	110	1,55
	84.0	82.5 ~ 85.5	14	110	1,55
	89.1	88.0 ~ 91.0	14	110	1,55
	101.6	100.0 ~ 103.0	14	110	1,55
DN100	104.0	102.0 ~ 105.0	14	110	1,73
	106.3	105.0 ~ 107.5	14	110	1,73
	108.0	106.0 ~ 109.0	14	110	1,73
	114.3	113.0 ~ 116.0	14	110	1,73
DN125	127.0	125.0 ~ 129.0	14	111	2,22
	129.0	127.5 ~ 130.0	14	111	2,22
	133.0	131.0 ~ 135.0	14	111	2,22
	139.8	138.0 ~ 142.0	14	111	2,22
	141.3	139.5 ~ 143.5	14	111	2,22
DN150	154.0	151.5 ~ 155.5	12	111	2,41
	159.0	156.0 ~ 160.0	12	111	2,41
	165.2	164.0 ~ 167.0	12	111	2,41
	168.3	166.0 ~ 170.0	12	111	2,41
DN175	180.0	178.0 ~ 182.0	10	111	2,41
DN200	200.0	198.0 ~ 203.0	8	150	5,18
	204.0	202.0 ~ 206.0	8	150	5,18
	216.3	214.0 ~ 218.5	8	150	5,18
	219.1	216.5 ~ 221.5	8	150	5,18
DN250	254.0	251.0 ~ 257.0	8	150	5,83
	267.4	262.0 ~ 269.0	8	150	5,83
	273.1	270.0 ~ 276.0	8	150	5,83
DN300	304.0	301.5 ~ 308.0	7	150	6,55
	318.5	316.0 ~ 322.5	7	150	6,55
	323.9	322.0 ~ 328.0	7	150	6,55
DN350	355.6	352.0 ~ 360.0	7	150	7,20
DN400	406.4	402.0 ~ 410.0	6	150	7,70
DN450	457.2	453.0 ~ 460.0	6	150	8,40
DN500	508.0	504.0 ~ 512.0	5	150	9,10
DN550	558.8	555.0 ~ 563.0	4.6	150	9,80
DN600	609.6	605.0 ~ 614.0	4.2	150	10,1

No	Part	Material	Code
1	Grip Ring	Stainless Steel	SS 304
2	Seal	NBR (810) EPDM (811)	

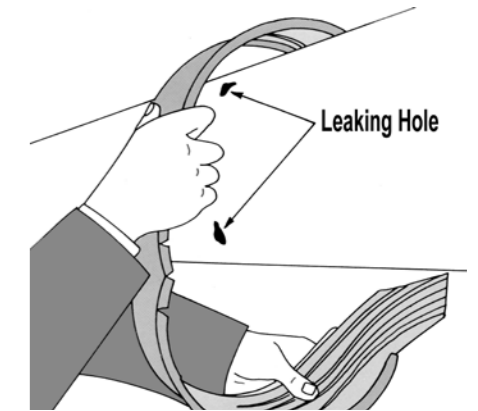
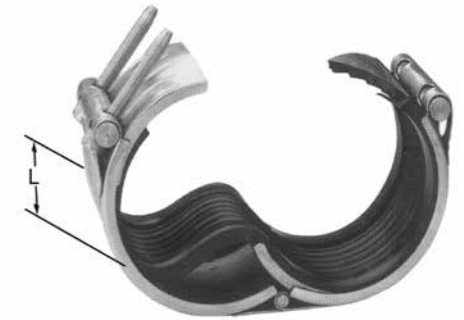



PIPE FITTINGS

Stainless steel pipe fittings in material AISI 316
Size range: 1/8" - 4"



PIPE FITTINGS

MATERIAL: STAINLESS STEEL SS316

Half Coupling R-203



Red. Coupling R-202



Hex Cap R-231

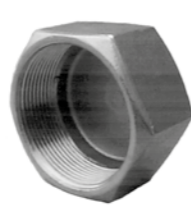

Full Coupling R-201



Hose Nipple R-106



Union M/F R-131U



90o Elbow R-222



90o Long Radius Elbow R-226



45o Elbow R-224



90o Street Elbow R-223



Hex.Nipple R-207



Welded Nipple R-208



Hex Bushing R-211



Hex.Head Plug R-236



Hex.Nut R-217



Tee R-221



Union F/F R-131



Red.Hex.Nipple R-209



Cross R-400



Taper Barrel Nipple R-210



Parallel Barrel Nipple R-206

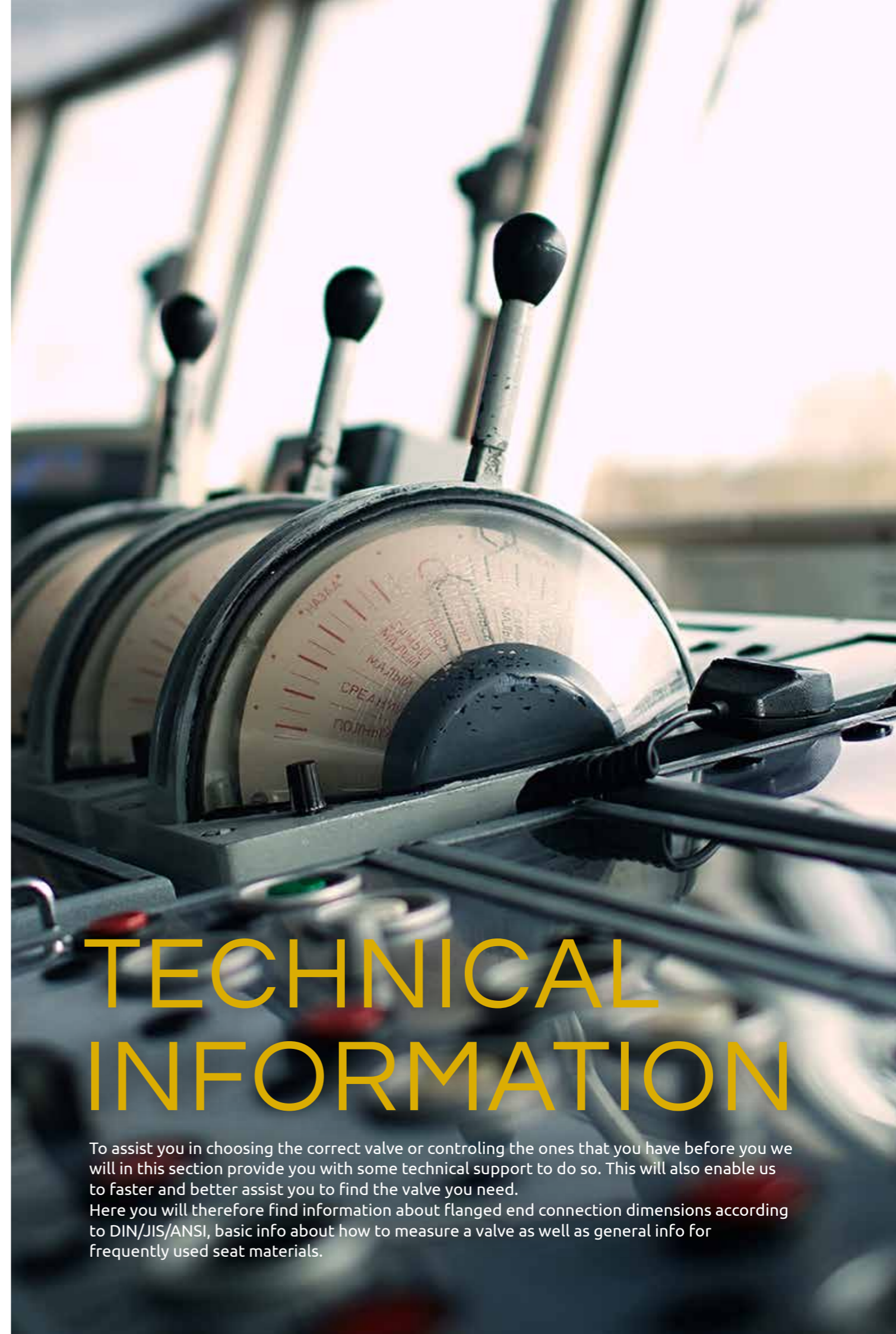

TECHNICAL INFORMATION

To assist you in choosing the correct valve or controlling the ones that you have before you we will in this section provide you with some technical support to do so. This will also enable us to faster and better assist you to find the valve you need. Here you will therefore find information about flanged end connection dimensions according to DIN/JIS/ANSI, basic info about how to measure a valve as well as general info for frequently used seat materials.



FLANGE DIMENSIONS

DIN

PN 6				
DN	D	n	Hcd	d
10	75	4	50	11
15	80	4	55	11
20	90	4	65	11
25	100	4	75	11
32	120	4	90	14
40	130	4	100	14
50	140	4	110	14
65	160	4	130	14
80	190	4	150	18
100	210	4	170	18
125	240	8	200	18
150	265	8	225	18
200	320	8	280	18
250	375	12	335	18
300	440	12	395	22
350	490	12	445	22
400	540	16	495	22
450	595	16	550	22
500	645	20	600	22
600	755	20	705	26

PN 10				
DN	D	n	Hcd	d
10	90	4	60	14
15	95	4	65	14
20	105	4	75	14
25	115	4	85	14
32	140	4	100	18
40	150	4	110	18
50	165	4	125	18
65	185	4	145	18
80	200	8	160	18
100	220	8	180	18
125	250	8	210	18
150	285	8	240	22
200	340	8	295	22
250	395	12	350	22
300	445	12	400	22
350	505	16	460	22
400	565	16	515	26
450	615	20	565	26
500	670	20	620	26
600	780	20	725	26

PN 16				
DN	D	n	Hcd	d
10	90	4	60	14
15	95	4	65	14
20	105	4	75	14
25	115	4	85	14
32	140	4	100	18
40	150	4	110	18
50	165	4	125	18
65	185	4	145	18
80	200	8	160	18
100	220	8	180	18
125	250	8	210	18
150	285	8	240	22
200	340	12	295	22
250	405	12	355	26
300	460	12	410	26
350	520	16	470	26
400	580	16	525	30
450	640	20	585	30
500	715	20	650	33
600	840	20	770	36

PN 25				
DN	D	n	Hcd	d
10	90	4	60	14
15	95	4	65	14
20	105	4	75	14
25	115	4	85	14
32	140	4	100	18
40	150	4	110	18
50	165	4	125	18
65	185	8	145	18
80	200	8	160	18
100	235	8	190	22
125	270	8	220	26
150	300	8	250	26
200	360	12	310	26
250	425	12	370	30
300	485	16	430	30
350	555	16	490	33
400	620	16	550	36
450	670	20	600	36
500	730	20	660	36
600	845	20	770	36



FLANGE DIMENSIONS

DIN

PN 40				
DN	D	n	Hcd	d
10	90	4	60	14
15	95	4	65	14
20	105	4	75	14
25	115	4	85	14
32	140	4	100	18
40	150	4	110	18
50	165	4	125	18
65	185	8	145	18
80	200	8	160	18
100	235	8	190	22
125	270	8	220	26
150	300	8	250	26
200	375	12	320	30
250	450	12	385	33
300	515	16	450	33
350	580	16	510	36
400	660	16	585	39
450	685	20	610	39
500	755	20	670	42
600	890	20	795	48

PN 64				
DN	D	n	Hcd	d
10	100	4	70	14
15	105	4	75	14
20	130	4	90	18
25	140	4	100	18
32	155	4	110	22
40	170	4	125	22
50	180	4	135	22
65	205	8	160	22
80	215	8	170	22
100	250	8	200	26
125	295	8	240	30
150	345	8	280	33
200	415	12	345	36
250	470	12	400	36
300	530	16	460	36
350	600	16	525	39
400	670	16	585	42
450	715	20	630	42
500	800	20	705	48
600	930	20	820	48

PN 100				
DN	D	n	Hcd	d
10	100	4	70	14
15	105	4	75	14
20	130	4	90	18
25	140	4	100	18
32	155	4	110	22
40	170	4	125	22
50	195	4	145	26
65	220	8	170	26
80	230	8	180	26
100	265	8	210	30
125	315	8	250	33
150	355	8	290	33
200	430	12	360	36
250	505	12	430	39
300	585	16	500	42
350	655	16	560	48
400	715	16	620	48
450	770	20	675	0
500	870	20	760	0
600	990	20	875	0

D = Flange diameter
n = Number of bolt holes
Hcd = Hole circle diameter
d = Diameter of bolt holes



FLANGE DIMENSIONS

JIS

DN	INCH	JIS 5K					JIS 10K					JIS 16K					JIS 20K				
		D	Hcd	d	BOLT mm	n	D	Hcd	d	BOLT mm	n	D	Hcd	d	BOLT mm	n	D	Hcd	d	BOLT mm	n
15	1/2	80	60	12	M10	4	95	70	15	M12	4	95	70	15	M12	4	95	70	15	M12	4
20	3/4	85	65	12	M10	4	100	75	15	M12	4	100	75	15	M12	4	100	75	15	M12	4
25	1	95	75	12	M10	4	125	90	19	M16	4	125	90	19	M16	4	125	90	19	M16	4
32	1.1/4	115	90	15	M12	4	135	100	19	M16	4	135	100	19	M16	4	135	100	19	M16	4
40	1.1/2	120	95	15	M12	4	140	105	19	M16	4	140	105	19	M16	4	140	105	19	M16	4
50	2	130	105	15	M12	4	155	120	19	M16	4	155	120	19	M16	8	155	120	19	M16	8
65	2.1/2	155	130	15	M12	4	175	140	19	M16	4	175	140	19	M16	8	175	140	19	M16	8
80	3	180	145	19	M16	4	185	150	19	M16	8	200	160	23	M20	8	200	160	23	M20	8
100	4	200	165	19	M16	8	210	175	19	M16	8	225	185	23	M20	8	225	185	23	M20	8
125	5	235	200	19	M16	8	250	210	23	M20	8	270	225	25	M22	8	270	225	25	M22	8
150	6	265	230	19	M16	8	280	240	23	M20	8	305	260	25	M22	12	305	260	25	M22	12
200	8	320	280	23	M20	8	330	290	23	M20	12	350	305	25	M22	12	350	305	25	M22	12
250	10	385	345	23	M20	12	400	355	25	M22	12	430	380	27	M24	12	430	380	27	M24	12
300	12	430	390	23	M20	12	445	400	25	M22	16	480	430	27	M24	16	480	430	27	M24	16
350	14	480	435	25	M22	12	490	445	25	M22	16	540	480	33	M30x3	16	540	480	33	M30x3	16
400	16	540	495	25	M22	16	560	510	27	M24	16	605	540	33	M30x3	16	605	540	33	M30x3	16
450	18	605	555	25	M22	16	620	565	27	M24	20	675	605	33	M30x3	20	675	605	33	M30x3	20
500	20	655	605	25	M22	20	675	620	27	M24	20	730	660	33	M30x3	20	730	660	33	M30x3	20
550	22	720	665	27	M24	20	745	680	33	M30	20	795	720	39	M36x3	20	795	720	39	M36x3	20
600	24	770	715	27	M24	20	795	730	33	M30	24	845	770	39	M36x3	24	845	770	39	M36x3	24
650	26	825	770	27	M24	24	845	780	33	M30	24	895	820	39	M36x3	24	945	850	48	M45x3	24
700	28	875	820	27	M24	24	905	840	33	M30	24	960	875	42	M39x3	24	995	900	48	M45x3	24
750	30	945	880	33	M30	24	970	900	33	M30	24	1020	935	42	M39x3	24	1080	970	56	M52x3	24
800	32	995	930	33	M30	24	1020	950	33	M30	28	1085	990	48	M45x3	24	1140	1030	56	M52x3	24
900	36	1095	1030	33	M30	24	1120	1050	33	M30	28	1185	1090	48	M45x3	28	1250	1140	56	M52x3	28
1000	40	1195	1130	33	M30	28	1235	1160	39	M36	28	1320	1210	56	M52x3	28					
1100	44	1305	1240	33	M30	28	1345	1270	39	M36	28	1420	1310	56	M52x3	32					
1200	48	1420	1350	33	M30	32	1465	1380	39	M36	32	1530	1420	56	M52x3	32					
1400	56											1755	1640	62	M52x3	36					

D = Flange diameter
Hcd = Hole circle diameter
d = Diameter of bolt holes
n = Number of bolt holes



FLANGE DIMENSIONS

ANSI

DN	INCH	ANSI CLASS 150					ANSI CLASS 300				
		D	Hcd	d	BOLT inch	n	D	Hcd	d	BOLT inch	n
15	1/2"	89	60	16	1/2"	4	95	67	16	1/2"	4
20	3/4"	98	69	16	1/2"	4	117	83	20	5/8"	4
25	1"	108	80	16	1/2"	4	124	89	20	5/8"	4
32	1.1/4"	118	89	16	1/2"	4	133	98	20	5/8"	4
40	1.1/2"	127	98	16	1/2"	4	156	114	23	3/4"	4
50	2"	152	121	20	5/8"	4	165	127	20	5/8"	8
65	2.1/2"	178	140	20	5/8"	4	190	149	23	3/4"	8
80	3"	190	152	20	5/8"	4	210	168	23	3/4"	8
100	4"	229	190	20	5/8"	8	254	200	23	3/4"	8
125	5"	254	216	23	3/4"	8	279	235	23	3/4"	8
150	6"	279	241	23	3/4"	8	318	270	23	3/4"	12
200	8"	343	298	23	3/4"	8	381	330	23	7/8"	12
250	10"	406	362	26	7/8"	12	445	387	32	1"	16
300	12"	483	431	26	7/8"	12	520	450	35	1.1/8"	16
350	14"	533	476	28	1"	12	584	514	35	1.1/8"	20
400	16"	597	540	29	1"	16	648	571	38	1.1/4"	20
450	18"	635	578	32	1.1/8"	16	710	629	35	1.1/4"	24
500	20"	698	635	32	1.1/8"	20	775	685	38	1.1/4"	24
600	24"	813	749	35	1.1/4"	20	915	813	42	1.1/2"	24
700	28"	927	864	35	1.1/4"	28	1035	940	45	1.1/2"	28
750	30"	984	914	35	1.1/4"	28	1098	997	48	1.3/4"	28
800	32"	1060	978	41	1.1/2"	28	1149	1054	51	1.3/4"	28
900	36"	1168	1086	41	1.1/2"	32	1270	1168	54	2"	32
1000	40"	1289	1200	41	1.1/2"	36					
1100	44"	1403	1314	41	1.1/2"	40					
1200	48"	1511	1422	41	1.1/2"	44					

D = Flange diameter
Hcd = Hole circle diameter
d = Diameter of bolt holes
n = Number of bolt holes



HOW TO MEASURE A VALVE

In order to supply correct valve we want information about dimensions acc to below.
If possible also medium, pressure and temperature.

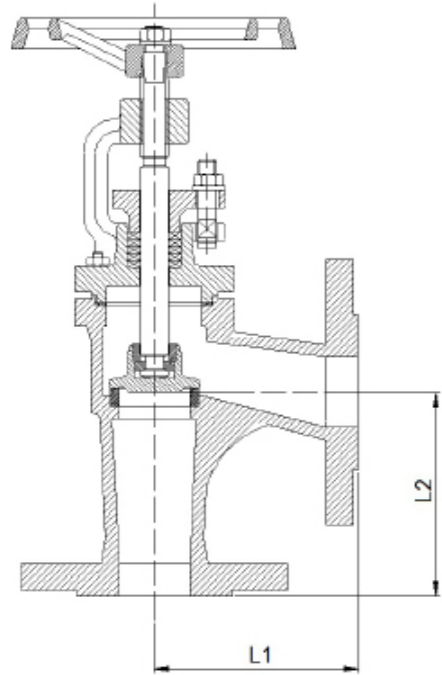

L1 = Face to Face Length
L1 = Face to Center Length
L2 = Face to Center Length

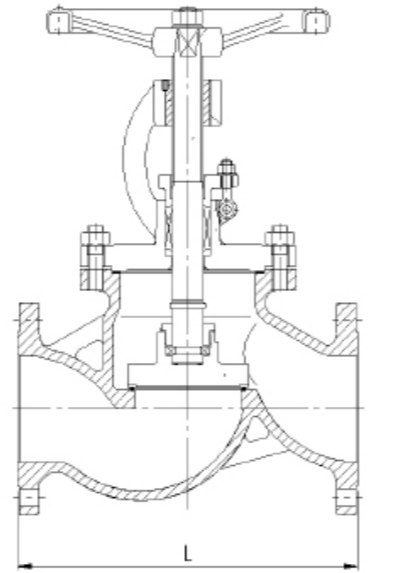

Please note raised face is included in L, L1 and L2

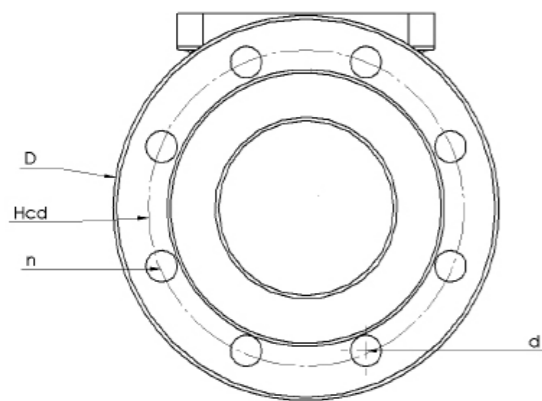

D = Flange diameter
Hcd = Hole circle diameter
d = Diameter of bolt holes
n = Number of bolt holes



VARIATIONS

GENERAL TERMS

- 000 Standard execution
- 099 Standard execution, undrilled flanges
- 097 Standard execution, flanges drilled ANSI-150
- 098 Standard execution, flanges drilled ANSI-300
- 020 EPDM
- 040 NBR
- 060 Viton

SAFETY VALVES

- 001-099 = Preset pressure in bar
- 619 PTFE seat adjustable 2-12 bar
- 620 PTFE seat adjustable 12-20 bar

STOP VALVES / SDNR

- 001 Bellow sealed with B.W ends
- 030 With indicator
- 096 undrilled SS trim Regulating disc
- 100 SDNR
- 101 SDNR free disc
- 103 Bellow sealed SDNR
- 104 Bellow sealed
- 105 Bellow sealed regulating disc
- 106 SS-trim Regulating disc
- 107 Conical Rg seat
- 108 PTFE seat
- 109 SS-trim
- 110 SS-trim SDNR
- 111 Rg trim Regulating disc
- 112 Rg trim
- 113 Rg trim SDNR
- 114 Butt weld ends
- 117 Conical Rg seat SDNR
- 118 PTFE seat SDNR
- 130 SDNR with indicator
- 131 SDNR free disc with indicator
- 140 Stem in mtrl. 1,4305
- 141 Stem in mtrl. 1,4305 SDNR
- 142 Stem/disc in mtrl. CuSn8
- 197 drilled ANSI-150 SDNR trim
- 198 drilled ANSI-300 SDNR trim
- 199 undrilled SDNR
- 501 with Gearbox
- 599 undrilled with Gearbox

GATE VALVES

- 001 SS stem Rg seat
- 002 SS trim
- 003 ALB stem
- 008 PTFE gland packing
- 011 Non rising stem, SS-stem Rg-seat
- 020 Soft seat EPDM
- 040 Soft seat NBR
- 112 Rg trim
- 114 Butt weld end
- 132 With indicator and locking device
- 160 PN 160
- 300 Soft seat NBR
- 301 SS-wedge soft seat NBR
- 501 With gearbox

BALL VALVES

- 007 25% carbon filled seats
- 077 Alu-bronze trim
- 078 Alu-bronze trim, NPT thread
- 109 SS-trim
- 132 Brass-stem SS-ball
- 133 Butterfly handle
- 292 PFA-lined drilled PN16
- 403 Direct mounting pad/ SS trim
- 404 Direct mounting pad/ Brass trim
- 407 Direct mounting pad/ ALB trim
- 408 Direct mounting pad/ Titan trim
- 413 Fire safe approved
- 423 Direct mounting pad SS316L
- 501 With gearbox
- 700 L-port
- 701 T-port
- BRA Brass-trim
- DMP Direct Mounting Pad

BUTTERFLY VALVES

- 099 undrilled
- 111 Metal seat
- 120 DNV rated
- 501 With gearbox

DIAPHRAGM VALVES

- 010 Natural rubber
- 020 EPDM
- 030 Butyl rubber
- 040 NBR rubber
- 050 Neoprene
- 060 Viton

CHECK VALVES

- 001 Tilting disc with gearbox
- 020 EPDM seat
- 040 NBR seat
- 050 PTFE seat
- 045 45 degree perf.
- 060 60 degree perf.
- 070 70 degree perf.
- 079 SS-disc Viton seat
- 103 Soft seat NBR
- 109 SS-seat
- 112 Rg-seat
- 113 Rg-seat
- 200 With spring
- 201 Floating ball
- 202 PTFE seat
- 204 Long type
- 250 PTFE seat with spring
- 299 Spigot flange end
- 312 Rg seat with counterw.

VARIOUS

- 001 Steam trap NPT-thread
- 200 Reducing valve
- 411 Reducing valve
- 412 Reducing valve
- 413 Reducing valve
- 414 Reducing valve
- 114 Butt weld end
- 155 With Storz-C Coupling and cap
- 156 With Storz-B Coupling
- 158 NH/NST-thread w. US pin lug blind cap

DIV

- NPT Tapered thread screwed
- NPS Straight thread screwed
- ACT Actuators
- HYD Hydraulic Actuator

FIG. NR	CHAPTER: PAGE	FIG. NR	CHAPTER: PAGE	FIG. NR	CHAPTER: PAGE	FIG. NR	CHAPTER: PAGE
130062	13:1	445192	8:20	475693	9:8	740702/01	6:12
159101	3:1	445194	8:21	479102	9:9	750709	22:1
159121	3:2	445197	18:3	479192	9:10	762962	6:13
159161	3:3	445198	18:4	481091	13:6	762992	6:14
159321	3:4	446152	8:22	481162	13:7	772962	6:15
159701	3:5	446292	8:23	481192	13:8	772992	6:16
159721	3:6	448095	8:24	481222	13:9	780702/02	6:11
159761	3:7	448162	8:25	482021	7:1	781702/01	
304222	3:8	448162 with gear	8:26	482051	7:2	782992	6:17
304291	3:9	448192	8:27	482061	7:3	841063/841163	11:1
304622	3:10	448395	8:28	482121	7:4	920301	11:2
305072	3:11	454022	1:1	482151	7:5	921602	11:3
305092	3:12	454122	1:2	482161	7:6	7H0000	6:18
305492	3:13	456022	1:4	482294	7:7	7V0000	6:19
305802/01	3:14	456065	1:5	482322	7:8	Butterfly Topflange	
312891	10:1	456066-144	1:6	483322	7:9	Dimensions	6:20
314022	10:2	456092	1:7	483402/01	7:10	WT Meson	12:1
315102/01	3:15	456122	1:8	483452/51	7:11	F-7301/F-7351	19:1
315192/91	3:16	456322	1:9	483464/63	7:12	F-7302/F-7355	19:2
315197	15:1	457432	1:10	483492	7:13	F-7303/F-7409	19:3
315202/01	3:17	458822/21	1:11	483497	17:1	F-7304/F-7410	19:4
319122	13:2	458922/21	1:12	483498	17:2	F-7305/F-7353	19:5
320022	3:18	460515	1:13	483662/61	7:14	F-7306/F-7354	19:6
335032	1:3	460895	1:14	483667	17:3	F-7307/F-7375	19:7
355922	5:1	460995	1:15	483692/91	7:15	F-7308/F-7376	19:8
356622	5:2	466694	1:16	483697	17:4	F-7309/F-7377	19:9
356722	5:3	467002/01	1:17	483852/51	7:16	F-7310/F-7378	19:10
357020	10:3	467003-104	1:23	484421	13:10	F-7311	19:11
357321	10:4	467052/51	1:18	485451	3:34	F-7312	19:12
357692	10:5	467064	1:19	490515	1:29	F-7313/F-7473	19:13
358002	10:6	467064-104	1:24	490615	1:30	F-7314/F-7474	19:14
358052	10:7	467065	1:26	567002/01	10:8	F-7319/F-7471	19:15
370202/01	3:19	467067	14:1	567022/21	10:9	F-7320/F-7472	19:16
370232/31	3:20	467068	14:2	567062/61	10:10	F-3060	20:1
370252/51	3:21	467092	1:27	567102/01	10:11	F-3061	20:2
370262	3:22	467094-104	1:25	567122/21	10:12	F-7363	21:1
370267	15:2	467097	14:3	567162/61	10:13	F-7364	21:2
394451	8:1	467098	14:4	620102/01	4:8	F-7366	21:3
394551	8:2	467102/01	1:20	620151	4:9	F-7367	21:4
396851	4:1	467152/51	1:21	620202	4:10	F-7368	21:5
396891	4:2	467164	1:22	620302/01	4:11	SA Series	23:1
398362	4:3	469052	2:1	620762	4:12	NA Series	23:2
400622	4:4	469252/51	2:2	620762-F4	4:13	SHA/S	23:3
400692	4:5	469651	2:3	620763	4:14	SHA/D	23:4
400822	4:6	469751	2:4	620764	4:15	MVS/MVD	23:5
401522/21	4:7	470022	3:23	620765	4:16	MTS	23:6
414212	9:1	470923	9:2	620766	4:17	MSV	23:7
440065	8:3	471023	9:3	620767	16:1	800/801	24:1
440095	8:4	471223	9:4	620768	16:2	810/811	24:2
440096	8:8	471494	3:24	621792	4:18	Pipe Fittings	25:1
440194	8:15	471762	1:28	700702/01	6:1	Flange Dimensions DIN	26:1
440565	8:5	472002/01	3:25	701702/01-702702/01		Flange Dimensions JIS	26:2
440595	8:6	472022/22	3:26	700703	6:4	Flange Dimensions ANSI	26:3
440596	8:9	472052/51	3:27	700772/71	6:2	How to measure a valve	26:4
440695	8:7	472064	3:28	701772/01-702772/01		Variations	26:5
442013	8:12	472401	3:29	700902/01	6:3		
442095	8:10	472451	3:30	701902/01-702902/01			
442095-403	8:11	473072	3:31	701903	6:5		
442113	8:13	473093	3:32	710702/01	6:6		
443024	8:14	473094	3:33	711702/01-712702/01			
445102	8:16	474322	9:5	710703	6:9		
445124/22-403	8:17	474961	13:3	710772/01	6:7		
445162	8:18	475062	13:4	711772/01-712772/01			
445164	8:19	475092	13:5	710902/01	6:8		
445167	18:1	475102	9:6	711902/01-712902/01			
445168	18:2	475302	9:7	711903	6:10		

Even though this catalogue has been compiled with the greatest care, the publisher cannot be held responsible for any possible errors and/or omissions and no rights may be derived from its content. The content in this catalogue should be considered as a reference guideline only and we reserve the right to change the given information/data at any point without prior notice.



3S

3P

2P